

Madison, Wisconsin

INDEX OF SHEETS

SHEET NO.	TITLE
1	TITLE
DI-D4	TYPICAL SECTIONS & DETAILS
D5	RAILROAD CROSSING DETAILS
D6	MEDIAN ISLANDS GRADING DETAIL
EC1-EC7	EROSION CONTROL PLANS
PI-P3	STREETS PLAN & PROFILE
UI-U5B	UTILITIES PLAN & PROFILE
U6-U9	STORM SEWER SCHEDULE
SI-S6	BOX CULVERT STRUCTURE PLANS
WI-W3	WATER MAIN PLAN & PROFILE
W4	WATER MATERIALS LIST & DETAILS
EI-E4	ELECTRICAL PLAN
PM1-PM2	PAVEMENT MARKINGS
XI-X43	STREET CROSS SECTIONS

CONVENTIONAL SIGNS	
FIELD VERIFY ALL UTILITY LOCATIONS	
GAS	G
STORM SEWER	ST
SANITARY SEWER	SAN
WATER	W
BURIED ELECTRIC	E
OVERHEAD ELECTRIC	OH
POWER POLE	
ADA COMPLIANT RAMP W/ DETECTABLE WARNING FIELD	
COMBUSTIBLE FLUIDS	

NOTES:

ALL GUTTERS SHALL DRAIN WITH A MINIMUM GRADE OF 0.50% TOWARD STORM SEWER INLETS.

SIDEWALK RAMPS AND CURB THRU SIDEWALK RAMPS SHALL HAVE A MAXIMUM SLOPE OF 1" PER 12". SIDEWALK AND CURB RAMPS SHALL BE CONSTRUCTED WITH A SIDE SLOPE OF 1.50%.

SIDEWALK SHALL HAVE A MINIMUM LONGITUDINAL SLOPE OF 0.50% AND A MAXIMUM LONGITUDINAL SLOPE OF 5.00% EXCEPT WHERE STREET GRADES EXCEED 5.00%.

EARTH WORK SUMMARY:

STREET EXCAVATION QTY (CITY VIEW DR.):
EXCAVATION CUT (MEASURED PLAN QUANTITY) 12597 C.Y.
ESTIMATED UNDISTRIBUTED UNDERCUT 2520 C.Y.

STORM SEWER EXCAVATION QTY:
EXCAVATION CUT (MEASURED PLAN QUANTITY) 665 C.Y.
ESTIMATED UNDISTRIBUTED UNDERCUT 265 C.Y.

TOTAL MEASURED PLAN QUANTITY 13262 C.Y.
TOTAL UNDISTRIBUTED UNDERCUT 2785 C.Y.

TOTAL UNCLASSIFIED EXCAVATION CUT 16047 C.Y.

CITY OF MADISON

CITY ENGINEERING DIVISION

DEPARTMENT OF PUBLIC WORKS

PLAN OF PROPOSED IMPROVEMENT

CITY VIEW DRIVE ASSESSMENT DISTRICT - 2020

CITY PROJECT NO. 11958

CONTRACT NO. 8313

CONSTRUCTION
PROJECT LOCATION

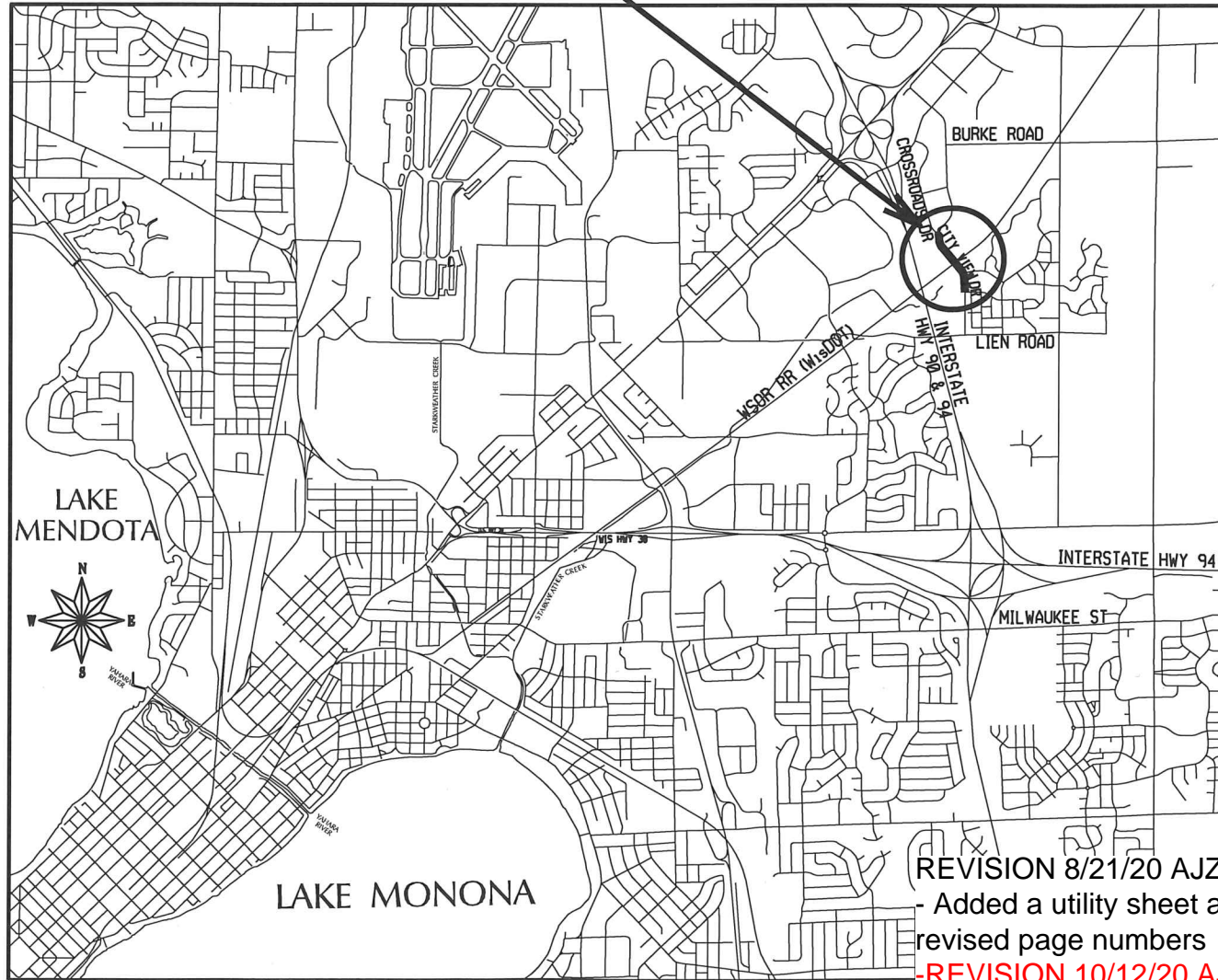

REVISION 8/21/20 AJZ
- Added a utility sheet and revised page numbers
-REVISION 10/12/20 AJZ
- Added a sewer schedule sheet

PUBLIC IMPROVEMENT PROJECT APPROVED

FEBRUARY 4, 2020

BY THE COMMON COUNCIL OF MADISON, WISCONSIN

PUBLIC IMPROVEMENT DESIGN APPROVED BY:

Christy Fed 3-17-20
City Engineer Date

SANITARY SEWER DESIGNED BY:

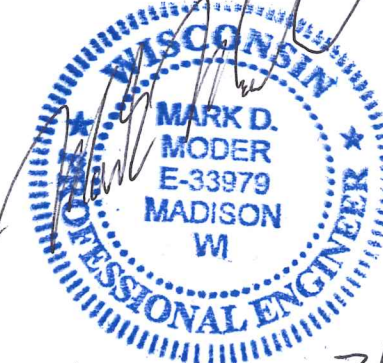

STREET DESIGNED BY:



WATER MAIN DESIGNED BY:

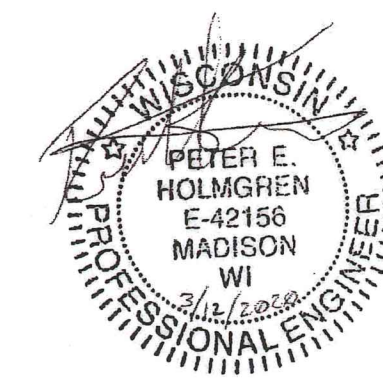

STORM SEWER DESIGNED BY:



GEOMETRICS & PAVEMENT MARKINGS DESIGNED BY:



ELECTRICAL DESIGNED BY:

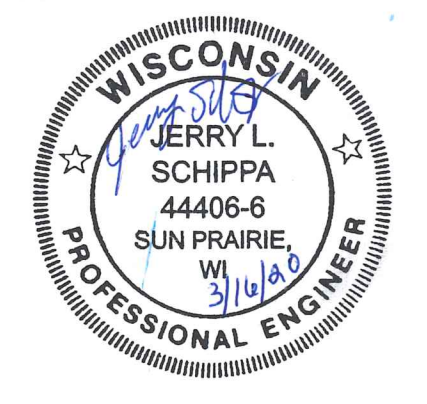

PLOT SCALE:

PLOT NAME:

REV. DATE:

ORIGINATOR: CITY OF MADISON, STREETS DIVISION

ORIGINATOR: CITY OF MADISON, STREET'S DIVISION
REV. DATE:
PLOT NAME:
PLOT SCALE:

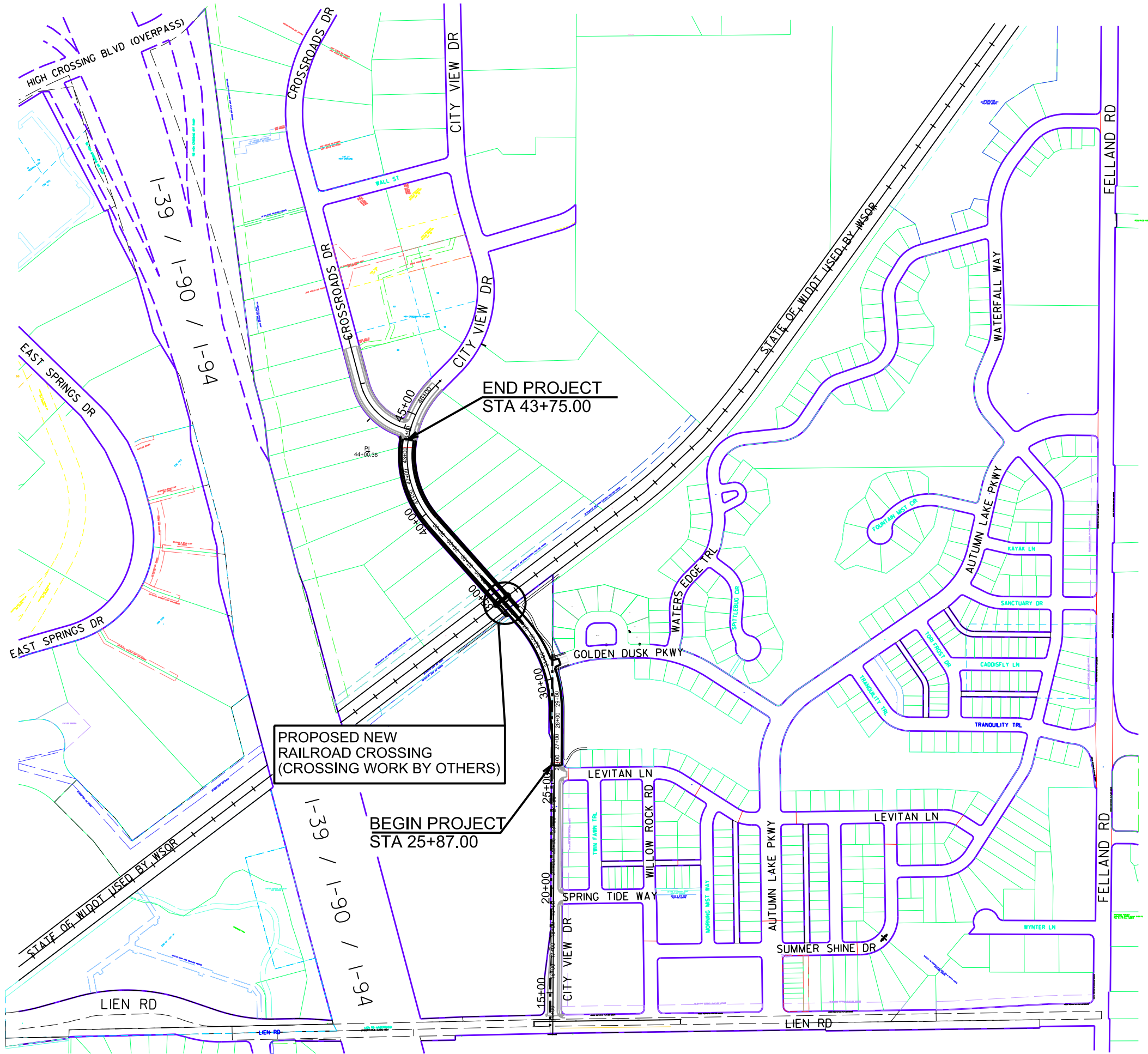

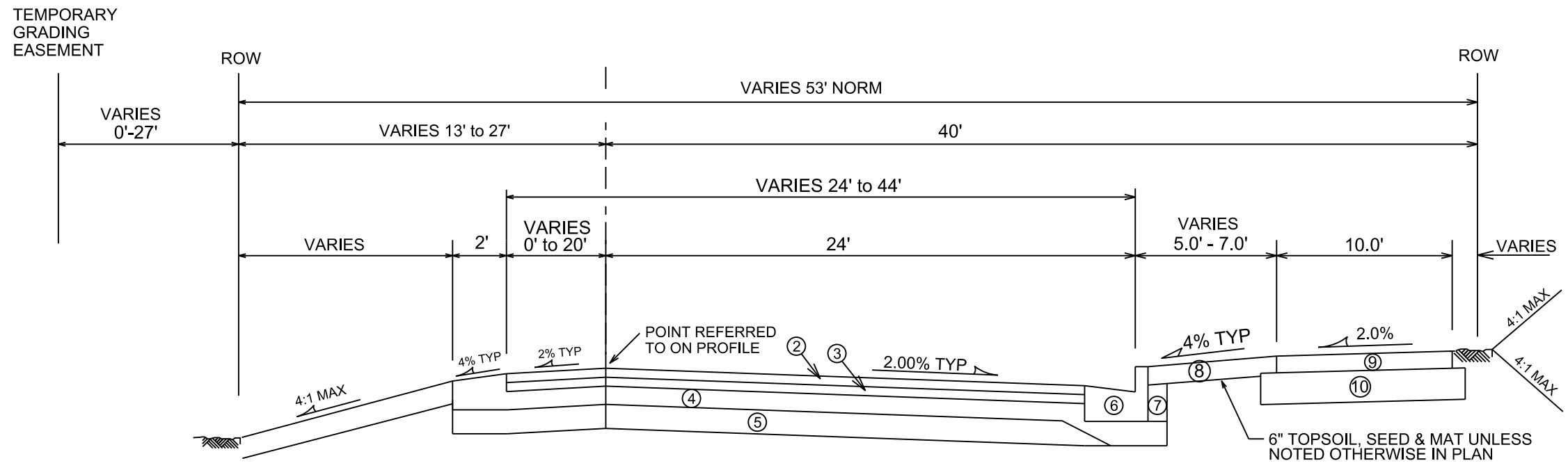

TYPICAL FINISHED SECTION
CITY VIEW DRIVE
STA 26+00 to STA 30+50
NOT TO SCALE

- ① POINT REFERRED TO ON PROFILE
- ② 2" BITUMINOUS UPPER LAYER, 4 MT 58-28 S
- ③ 3 1/2" BITUMINOUS LOWER LAYER, 3 MT 58-28 S
- ④ 6" GRADATION 2 CRUSHED STONE
- ⑤ 6" GRADATION 1 CRUSHED STONE
- ⑥ TYPE 'A' OR 'X' CONCRETE CURB & GUTTER
- ⑦ FILL, INCIDENTAL
- ⑧ 6" TOPSOIL, SEED & MAT
- ⑨ 3" BITUMINOUS BIKE PATH, 4 LT 58-28 S
- ⑩ 8" GRADATION 2 CRUSHED STONE

* SEE CROSS SECTION SHEETS FOR CROSS SLOPES AND TOP OF CURB ELEVATIONS.

TYPICAL SECTIONS NOT TO SCALE

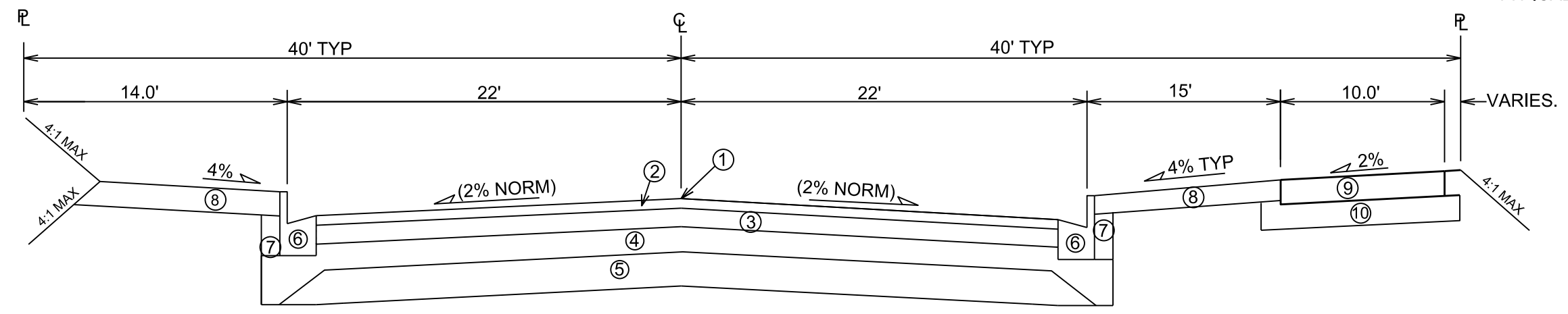

TYPICAL FINISHED SECTION
CITY VIEW DRIVE
STA 30+75 to STA 32+75

PLOT SCALE: _____

PLOT NAME: _____

REV. DATE: _____

ORIGINATOR: CITY OF MADISON, STREETS DIVISION

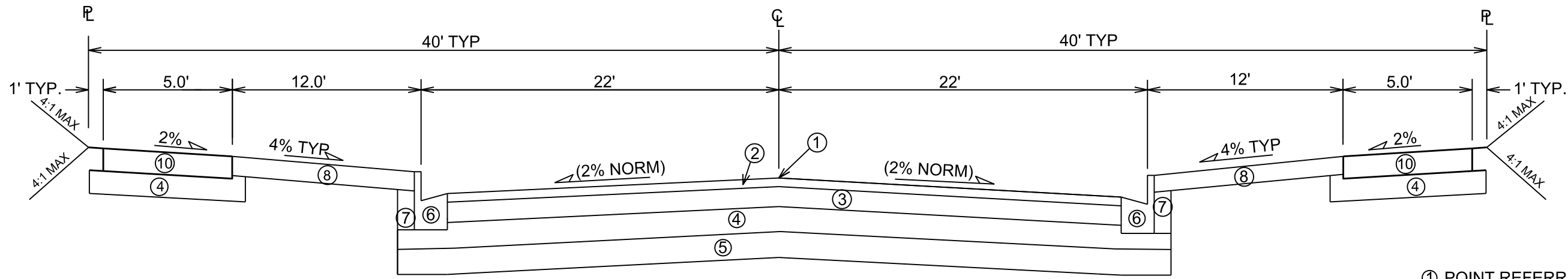

TYPICAL FINISHED SECTION
CITY VIEW DRIVE
STA 36+00 to STA 43+75

- ① POINT REFERRED TO ON PROFILE
- ② 2" BITUMINOUS UPPER LAYER, 4 MT 58-28 S
- ③ 3 1/2" BITUMINOUS LOWER LAYER, 3 MT 58-28 S
- ④ 6" GRADATION 2 CRUSHED STONE
- ⑤ 6" GRADATION 1 CRUSHED STONE
- ⑥ TYPE 'A' OR 'X' CONCRETE CURB & GUTTER
- ⑦ FILL, INCIDENTAL
- ⑧ 6" TOPSOIL, SEED & MAT
- ⑨ 3" BITUMINOUS BIKE PATH, 3 LT 58-28 S
- ⑩ 5" CONCRETE SIDEWALK

* SEE CROSS SECTION SHEETS FOR CROSS SLOPES AND TOP OF CURB ELEVATIONS.

TYPICAL SECTIONS NOT TO SCALE

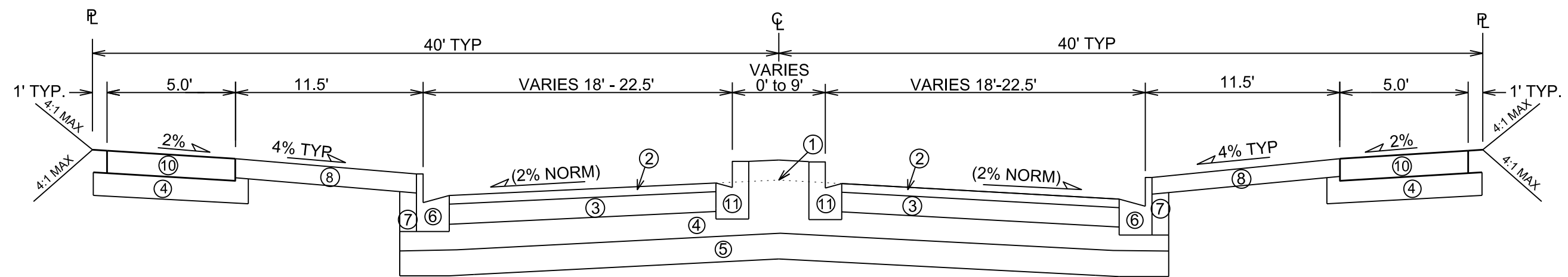

TYPICAL FINISHED SECTION
CITY VIEW DRIVE
STA 33+00 to STA 36+00

PLOT SCALE: _____

PLOT NAME: _____

REV. DATE: _____

ORIGINATOR: CITY OF MADISON - STREETS DIVISION

DETAILS

CLEARING & GRUBBING LIMITS

CITY OF MADISON



NOTES:

- 1) CLEAR AND GRUB ALL HATCHED AREAS
- 2) CLEAR AND GRUB SHALL BE PAID BY THE STATION
- 3) CLEAR AND GRUB ALL TREES AND BRUSH TO WITHIN 1-FOOT OF ROW AND TLE LINES.
- 4) COORDINATE CLEARING AND GRUBBING ON RAILROAD ROW WITH WSOR PER SECTION 107.12 OF THE CONTRACT SPECIAL PROVISIONS. CONTACT ROGER SCHAALMA, (608) 620-2044.

CLEAR & GRUB QUANTITIES

AREA 1) 25' x 300'	= 3.00 STATIONS
AREA 2) 25' x 300'	= 3.00 STATIONS
AREA 3) 30' x 285'	= 2.85 STATIONS
AREA 4) 40' x 175'	= 1.75 STATIONS
TOTAL:	10.60 STATIONS

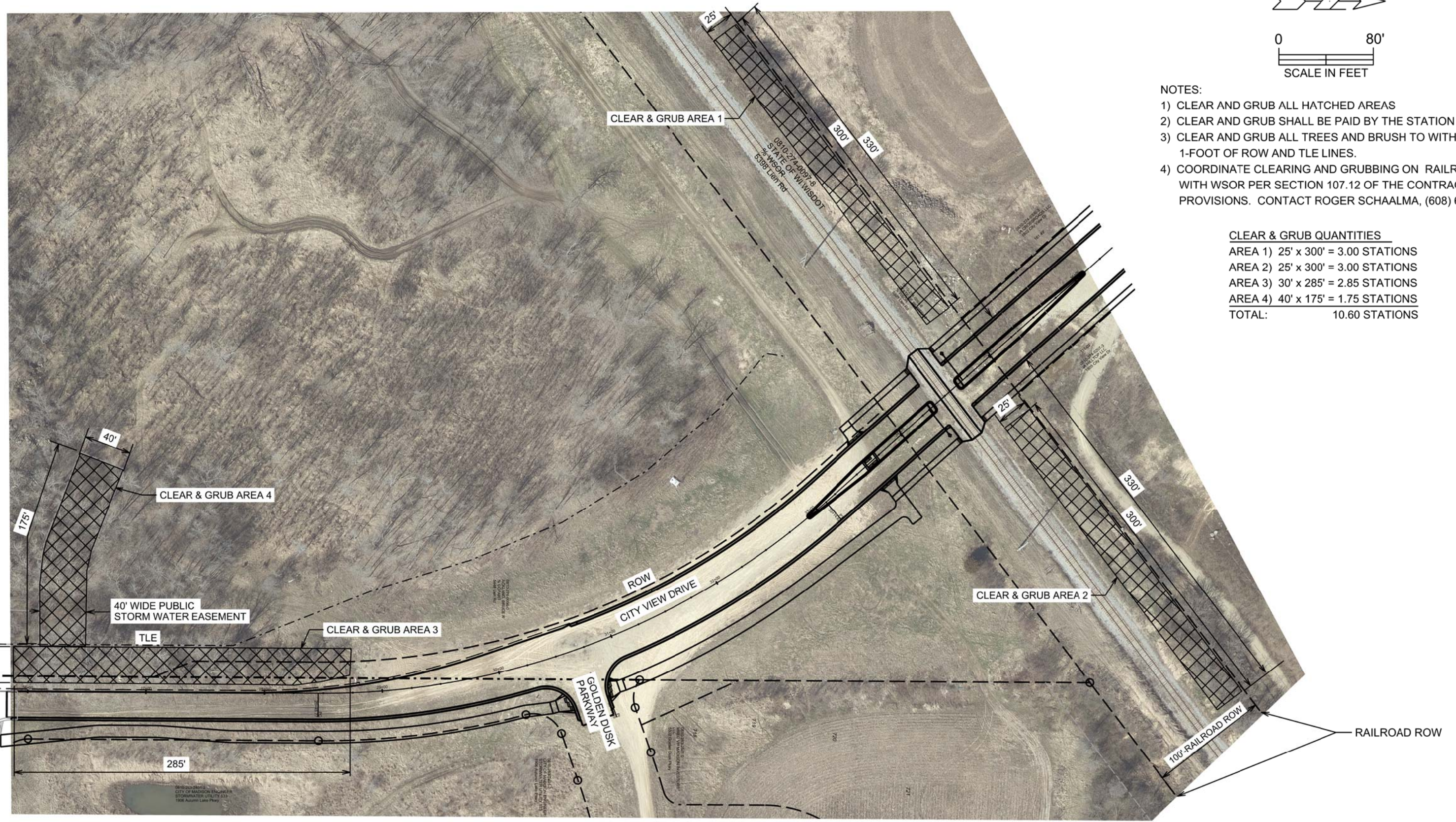

PLOT NAME: _____
REV. DATE: _____
ORIGINATOR: CITY OF MADISON, STREETS DIVISION

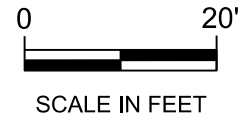
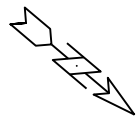

0810-274-0096-0
ACKLAND, BRUCE R
% COPART
5448 LIEN ROAD

0810-274-0097-8
STATE OF WI WISDOT
% WISCONSIN & SOUTHERN RR
5398 LIEN ROAD

0810-274-0306-3
IA CITY VIEW LLC
1802 CITY VIEW DRIVE

161.49'

EXISTING ROW

EXISTING ROW

5' CONCRETE SIDEWALK

5' CONCRETE SIDEWALK

CITY VIEW DRIVE

33+00

34+00

35+00

36+00

RAISED
MEDIAN

RAISED
MEDIAN

STOP BAR

RR GATE & WARNING
DEVICES (BY OTHERS)
STOP BAR

CITY VIEW DRIVE

33+14.82
PT

RR GATE &
WARNING
DEVICES
(BY OTHERS)

5' CONCRETE SIDEWALK

5' CONCRETE SIDEWALK

PROPOSED 10' ASPHALT PATH

EXISTING ROW

0810-263-5722-9
CITY OF MADISON ENGINEER
STORMWATER UTILITY
1908 AUTUMN LAKE PARKWAY

0810-274-0097-8
STATE OF WI WISDOT
% WISCONSIN & SOUTHERN RR
5398 LIEN ROAD

0810-274-0207-3
IA CITY VIEW LLC
1805 CITY VIEW DRIVE

110.02'

100' - RAILROAD ROW

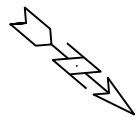



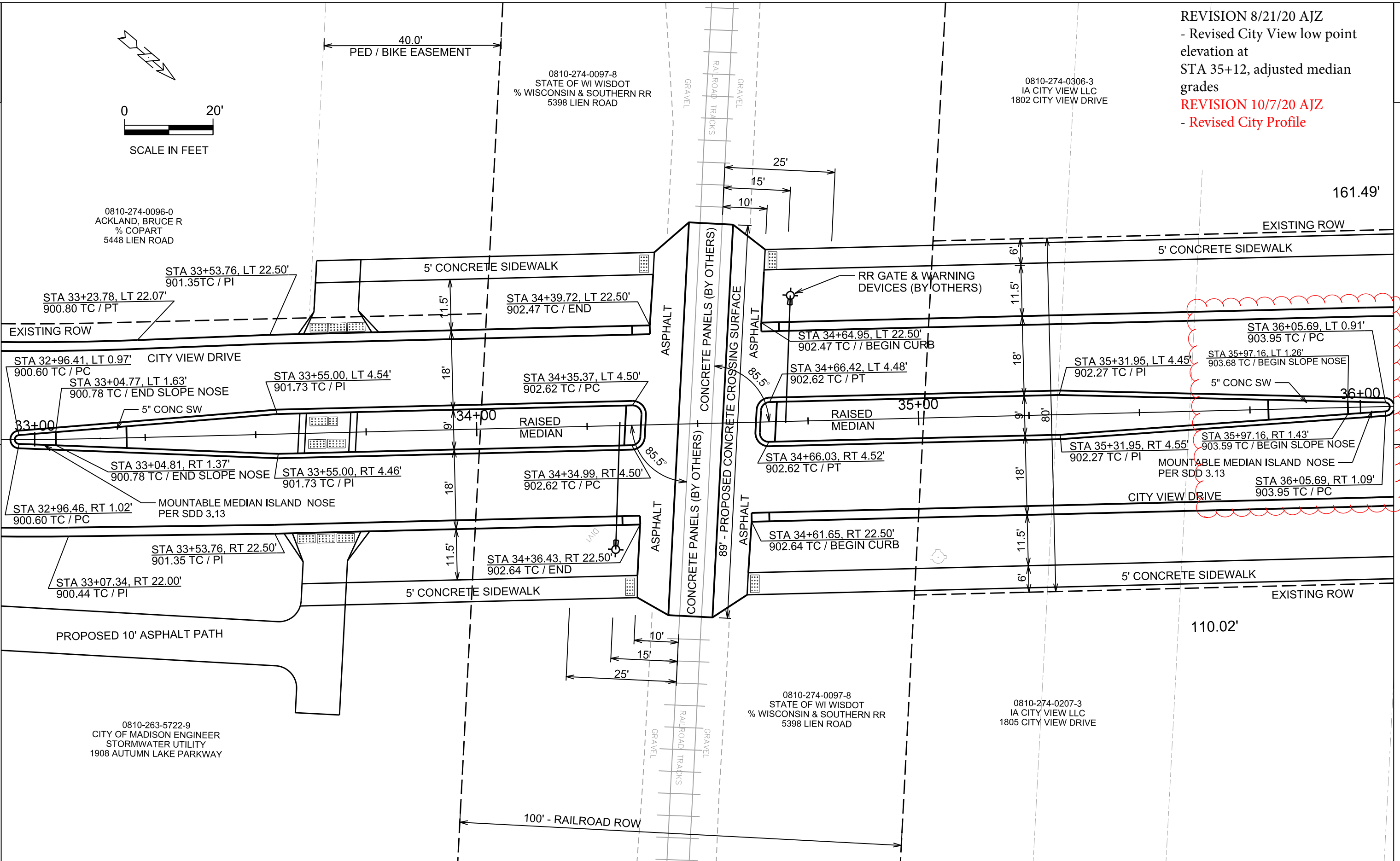



REVISION 8/21/20 AJZ
 - Revised City View low point elevation at STA 35+12, adjusted median grades
 REVISION 10/7/20 AJZ
 - Revised City Profile



EROSION CONTROL & RESTORATION PLAN

CITY OF MADISON

-  STREET CONSTRUCTION ENTRANCE BERM
-  CONSTRUCTION ENTRANCE
-  TYPE D HYBRID INLET PROTECTION
-  TYPE C INLET PROTECTION
-  SILT SOCK (VELOCITY CHECK)
-  STREET CONSTRUCTION STONE BERM

- EROSION CONTROL NOTES:**
- 1) EROSION CONTROL MEASURES SHALL BE IN PLACE PRIOR TO ANY OTHER CONSTRUCTION ACTIVITIES.
 - 2) THE CONTRACTOR IS RESPONSIBLE FOR THE CONSTRUCTION AND MAINTENANCE OF ALL EROSION CONTROL MEASURES UNTIL FINAL ACCEPTANCE BY THE CITY OF MADISON.
 - 3) THE CONTRACTOR SHALL INSTALL AND MAINTAIN EROSION CONTROL MEASURES IN ACCORDANCE WITH THE WDNR SOC STANDARDS AND CITY OF MADISON STANDARD SPECIFICATIONS.
 - 4) THE CONTRACTOR SHALL PROVIDE STREET SWEEPING AS NEEDED ON A DAILY BASIS TO KEEP TRACKING TO A MINIMUM.
 - 5) THE CONTRACTOR SHALL BE RESPONSIBLE FOR ALL STORM WATER CONTROL MEASURES NECESSARY WITHIN THE CHANNEL AND ASSOCIATED DRAINAGES.
 - 6) POLYMER SHALL BE APPLIED TO DISTURBED AREAS AS DIRECTED BY THE CONSTRUCTION ENGINEER.
 - 7) NO CONSTRUCTION MATERIALS OR STOCKPILES SHALL BE STORED IN THE CHANNEL.
 - 8) CHECK DAMS SHALL BE CONSTRUCTED IN THE LOW-FLOW CHANNEL AS SHOWN IN THE PLAN SET, OR AS DIRECTED BY THE CONSTRUCTION ENGINEER.
 - 9) THE CONTRACTOR SHALL INSTALL SILT FENCE OR SILT SOCK AT THE DIRECTION OF THE CONSTRUCTION ENGINEER.
 - 10) ALL EROSION CONTROL MATTING SHALL BE OVERLAPPED SUCH THAT THE OVERLAP CORRESPONDS TO THE FLOW DIRECTION.
 - 11) ADDITIONAL INLET PROTECTION MAY BE REQUIRED OUTSIDE THE LIMITS OF THIS SHEET.
 - 12) THE CONTRACTOR SHALL USE APPROPRIATE CONCRETE WASTE CATCHMENT. ALL POINTS ON THIS SITE DRAIN DIRECTLY TO THE GREENWAY.

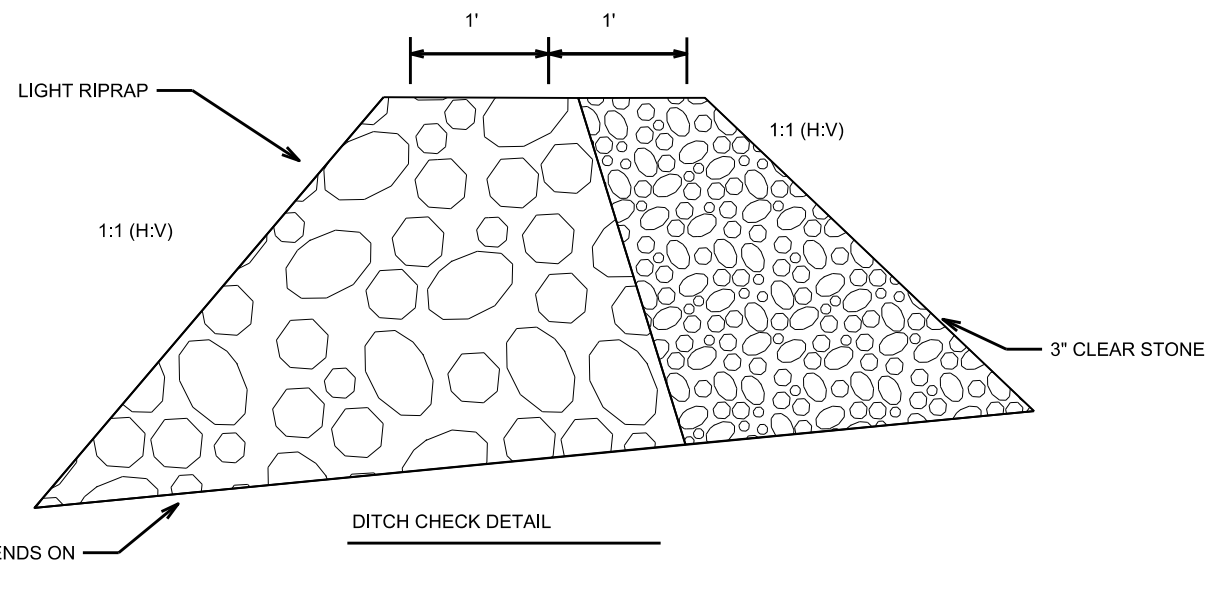
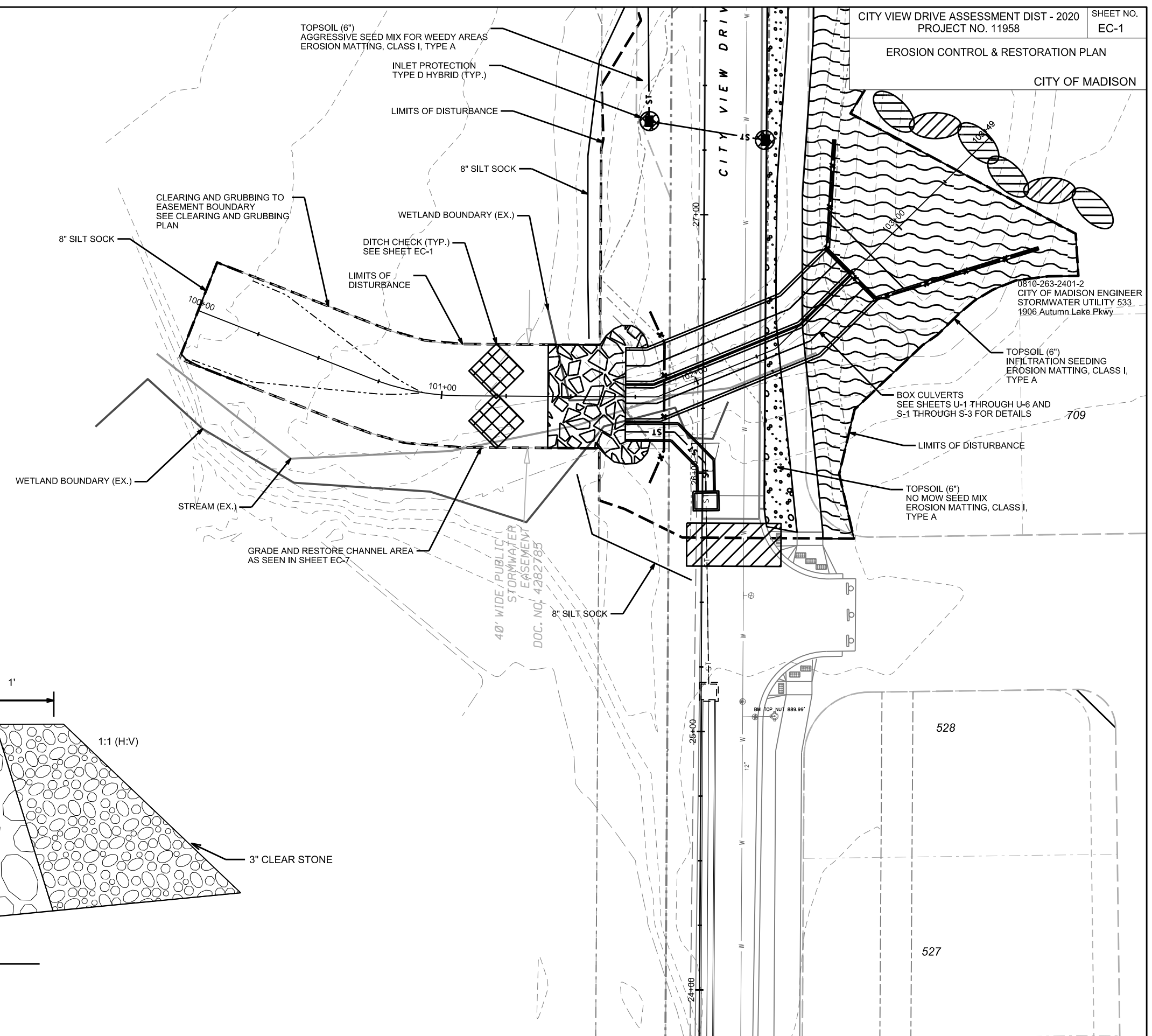

PLOT SCALE: _____
PLOT NAME: _____
REV. DATE: _____







ORIGINATOR: CITY OF MADISON, STREETS DIVISION

EROSION CONTROL & RESTORATION PLAN

CITY VIEW DRIVE CITY OF MADISON

REV
06/10/20

LES

-  STREET CONSTRUCTION ENTRANCE BERM
-  CONSTRUCTION ENTRANCE
-  TYPE D HYBRID INLET PROTECTION
-  TYPE C INLET PROTECTION
-  SILT SOCK (VELOCITY CHECK)
-  STREET CONSTRUCTION STONE BERM

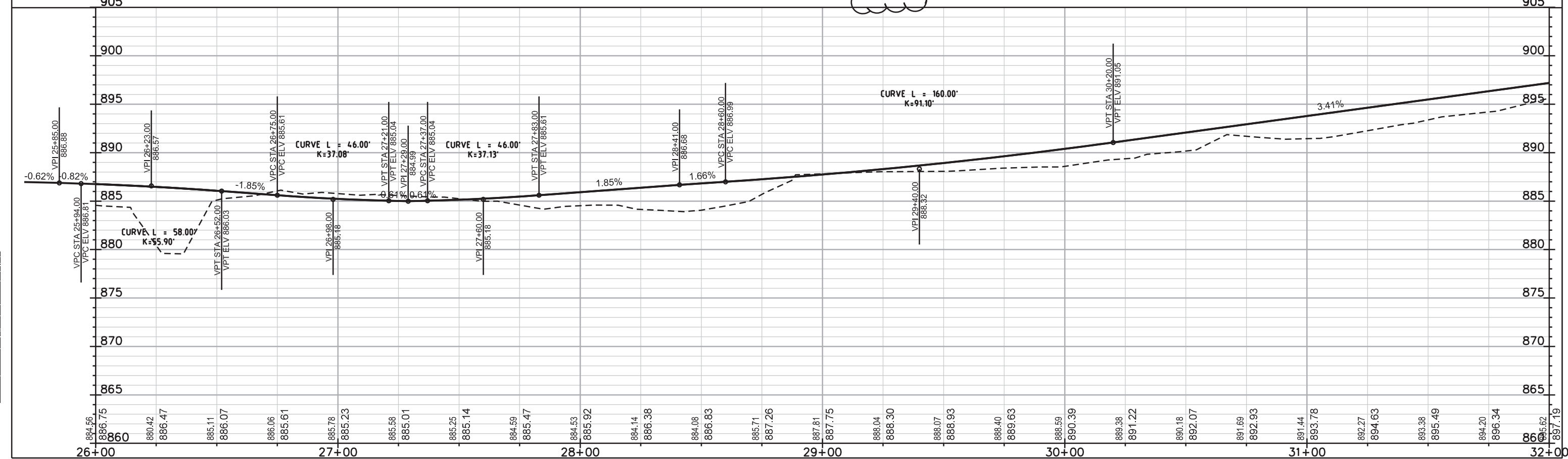
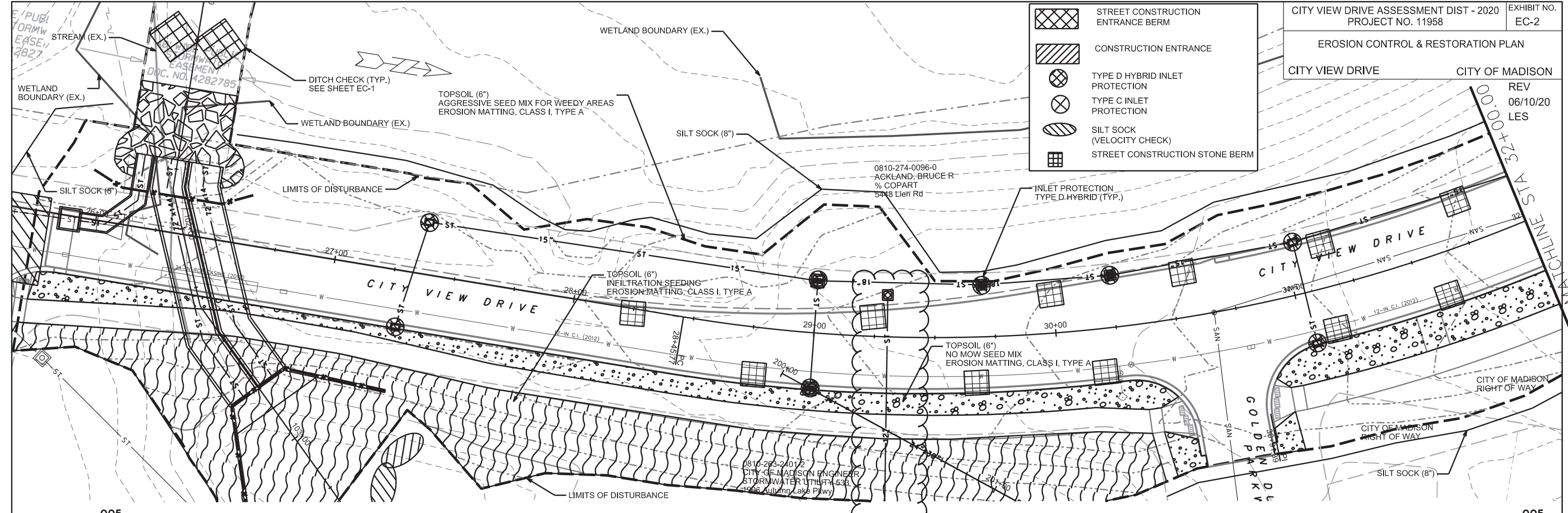







REV. DATE: _____

ORIGINATOR: CITY OF MADISON, STREETS DIVISION

EROSION CONTROL & RESTORATION PLAN

REV 10/7/20 LES

-  STREET CONSTRUCTION ENTRANCE BERM
-  CONSTRUCTION ENTRANCE
-  TYPE D HYBRID INLET PROTECTION
-  TYPE C INLET PROTECTION
-  SILT SOCK (VELOCITY CHECK)
-  STREET CONSTRUCTION STONE BERM

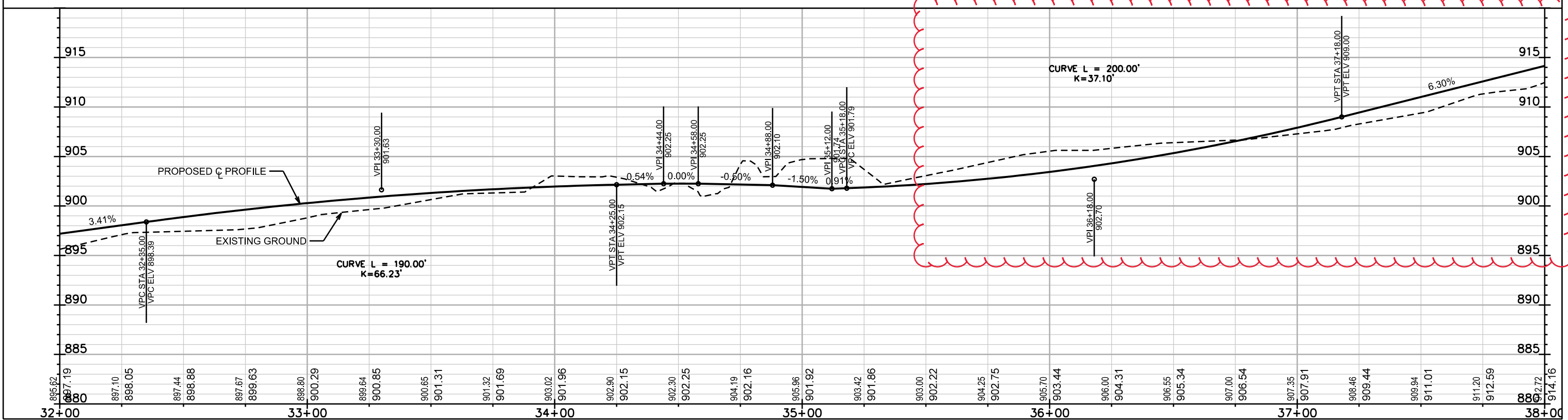
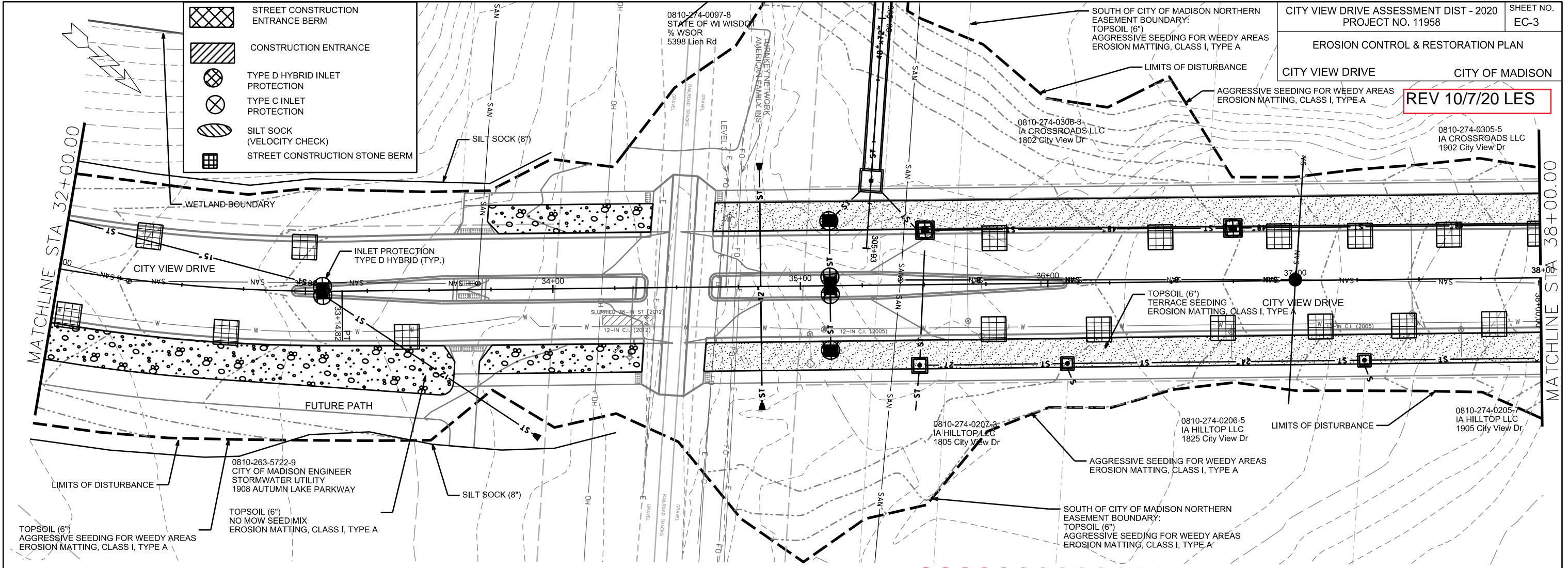

PLOT SCALE:

REV. DATE:

ORIGINATOR: CITY OF MADISON, STREETS DIVISION

REV 10/7/20 LES

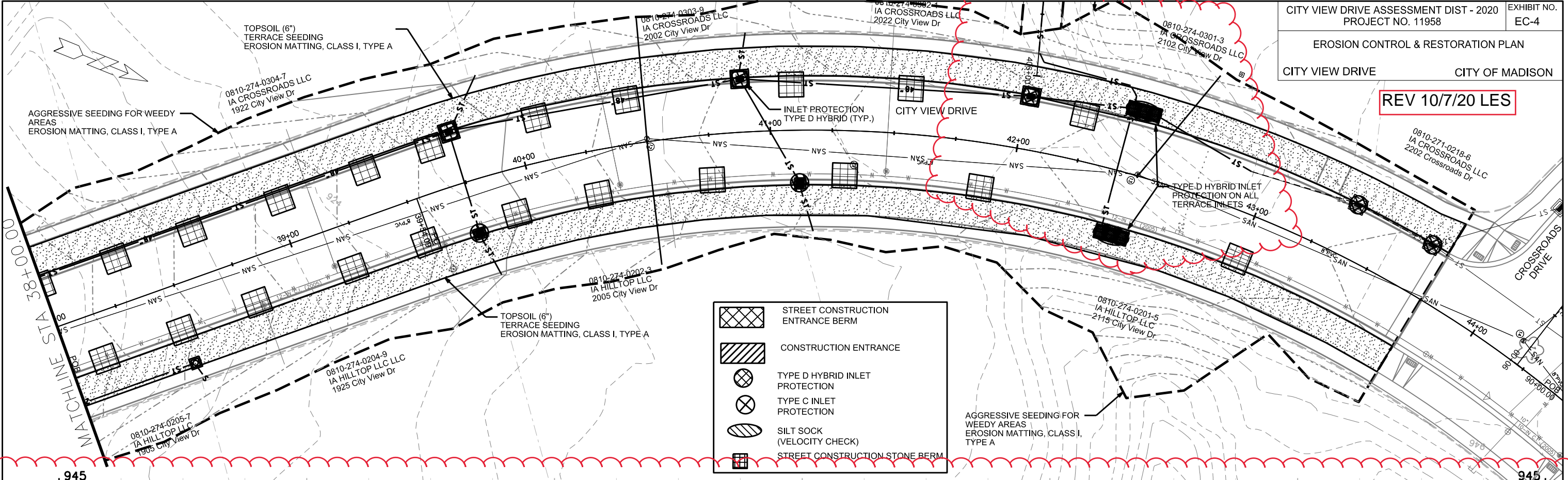

	STREET CONSTRUCTION ENTRANCE BERM
	CONSTRUCTION ENTRANCE
	TYPE D HYBRID INLET PROTECTION
	TYPE C INLET PROTECTION
	SILT SOCK (VELOCITY CHECK)
	STREET CONSTRUCTION STONE BERM

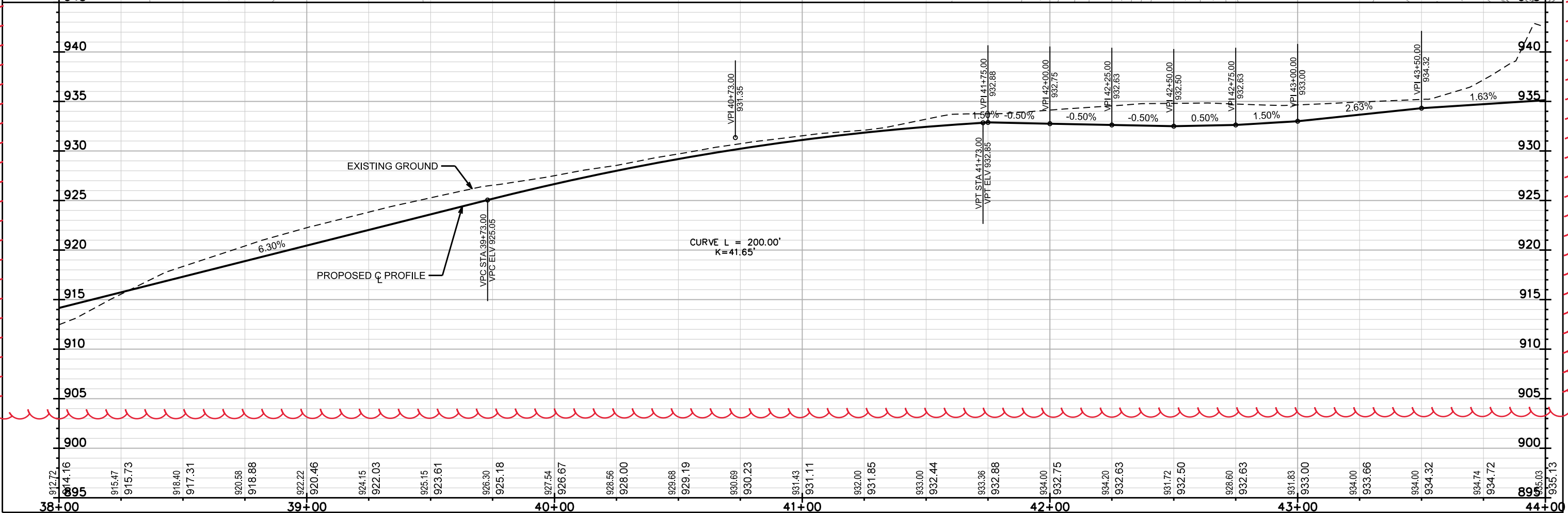

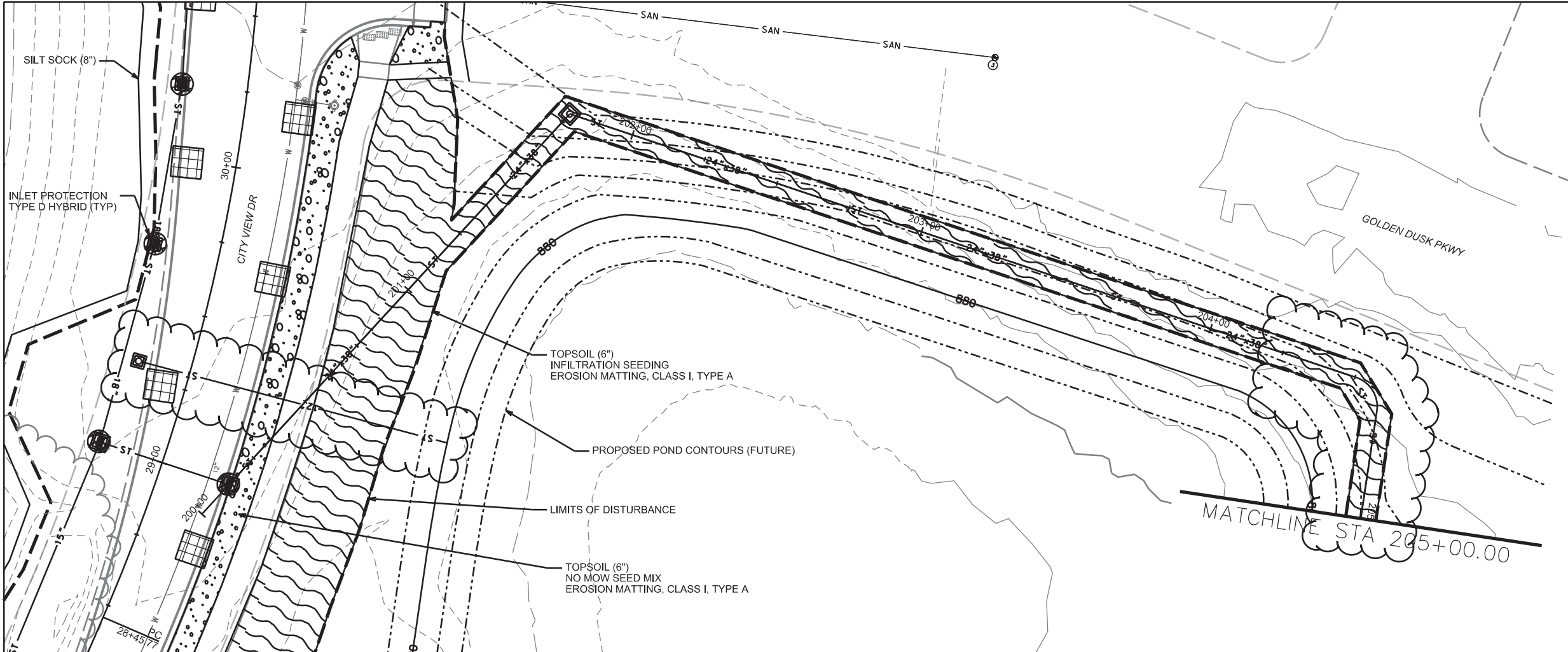

	STREET CONSTRUCTION ENTRANCE BERM
	CONSTRUCTION ENTRANCE
	TYPE D HYBRID INLET PROTECTION
	TYPE C INLET PROTECTION
	SILT SOCK (VELOCITY CHECK)
	STREET CONSTRUCTION STONE BERM

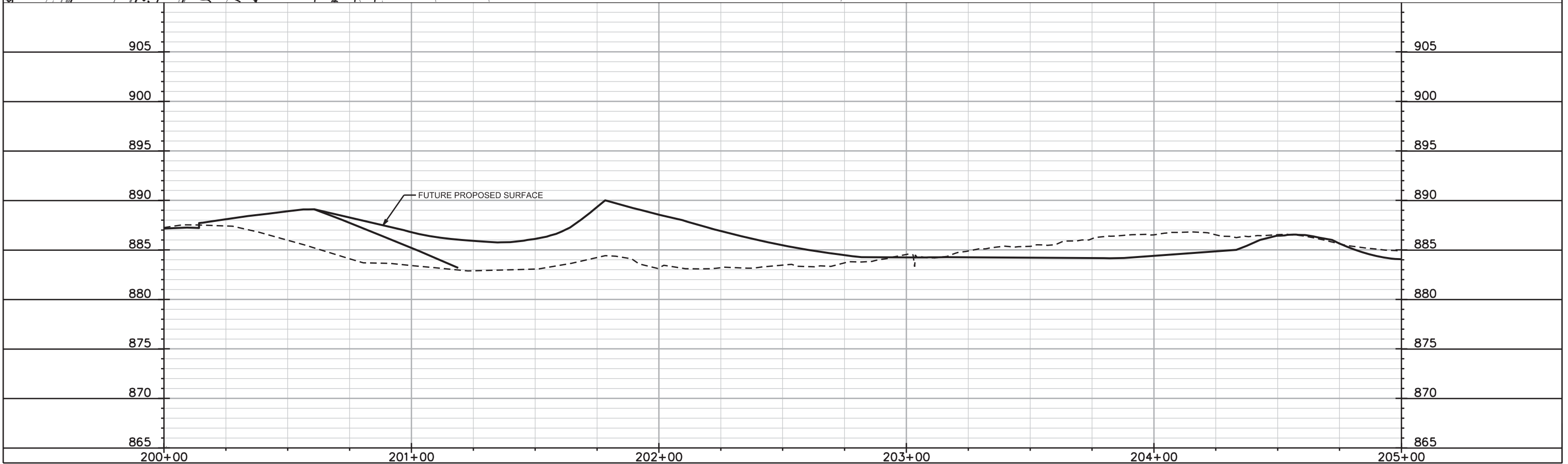

PLOT SCALE: _____







PLOT NAME: _____

REV. DATE: _____

ORIGINATOR: CITY OF MADISON, STREETS DIVISION

EROSION CONTROL & RESTORATION PLAN

STORM DISCHARGE - SOUTH CITY OF MADISON
REV 7/9/20 LES

-  STREET CONSTRUCTION ENTRANCE BERM
-  CONSTRUCTION ENTRANCE
-  TYPE D HYBRID INLET PROTECTION
-  TYPE C INLET PROTECTION
-  SILT SOCK (VELOCITY CHECK)
-  STREET CONSTRUCTION STONE BERM

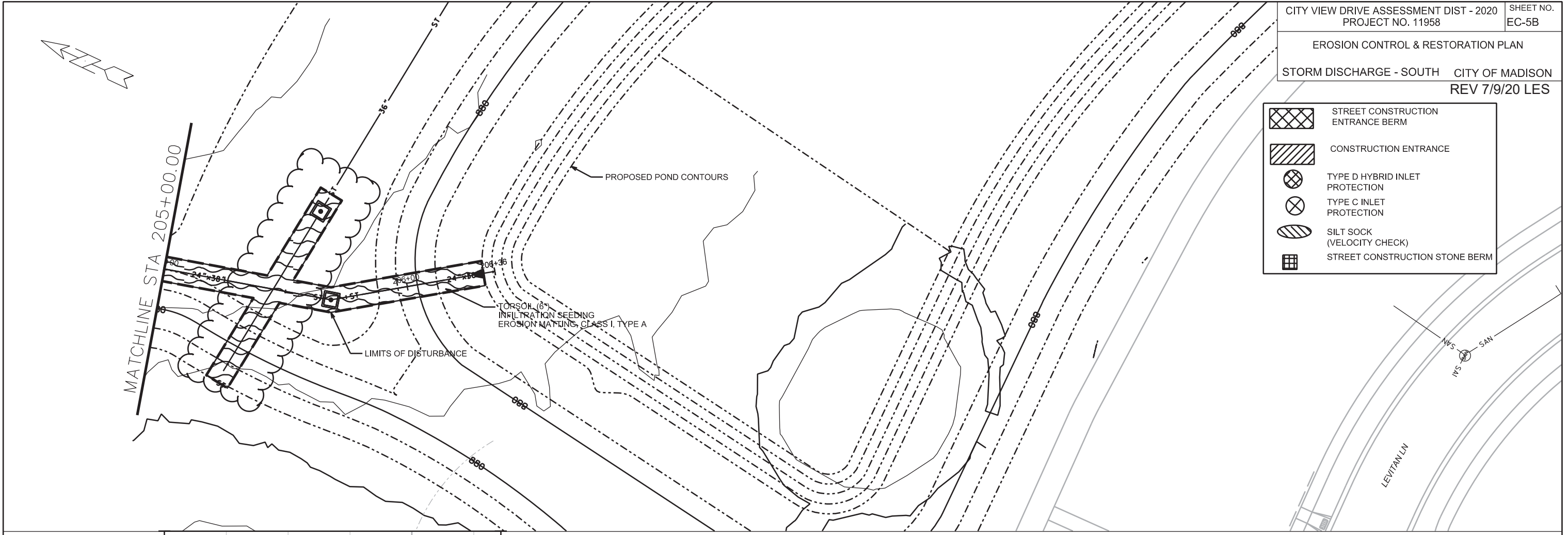

PLOT SCALE: _____

PLOT NAME: _____

REV. DATE: _____

ORIGINATOR: CITY OF MADISON, STREETS DIVISION







REV. LES 08/21/20

CITY VIEW DR ASSESSMENT DIST - 2020
PROJECT NO. 11958

SHEET NO.
EC-6

EROSION CONTROL & RESTORATION PLAN

STORM DISCHARGE NORTH CITY OF MADISON

-  STREET CONSTRUCTION ENTRANCE BERM
-  CONSTRUCTION ENTRANCE
-  TYPE D HYBRID INLET PROTECTION
-  TYPE C INLET PROTECTION
-  SILT SOCK (VELOCITY CHECK)
-  STREET CONSTRUCTION STONE BERM

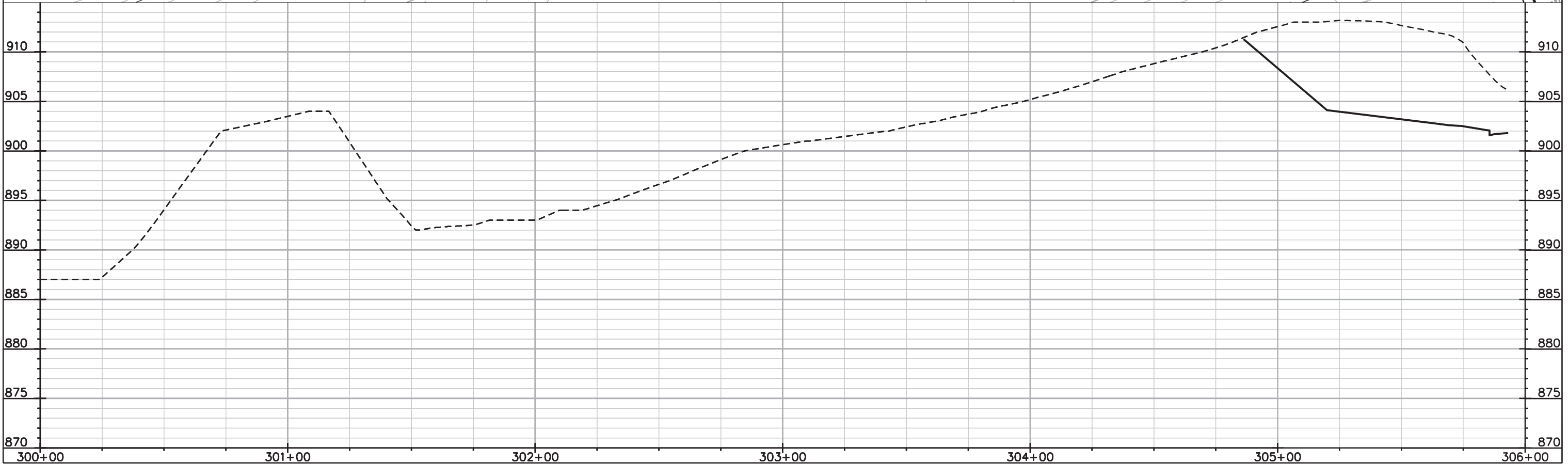
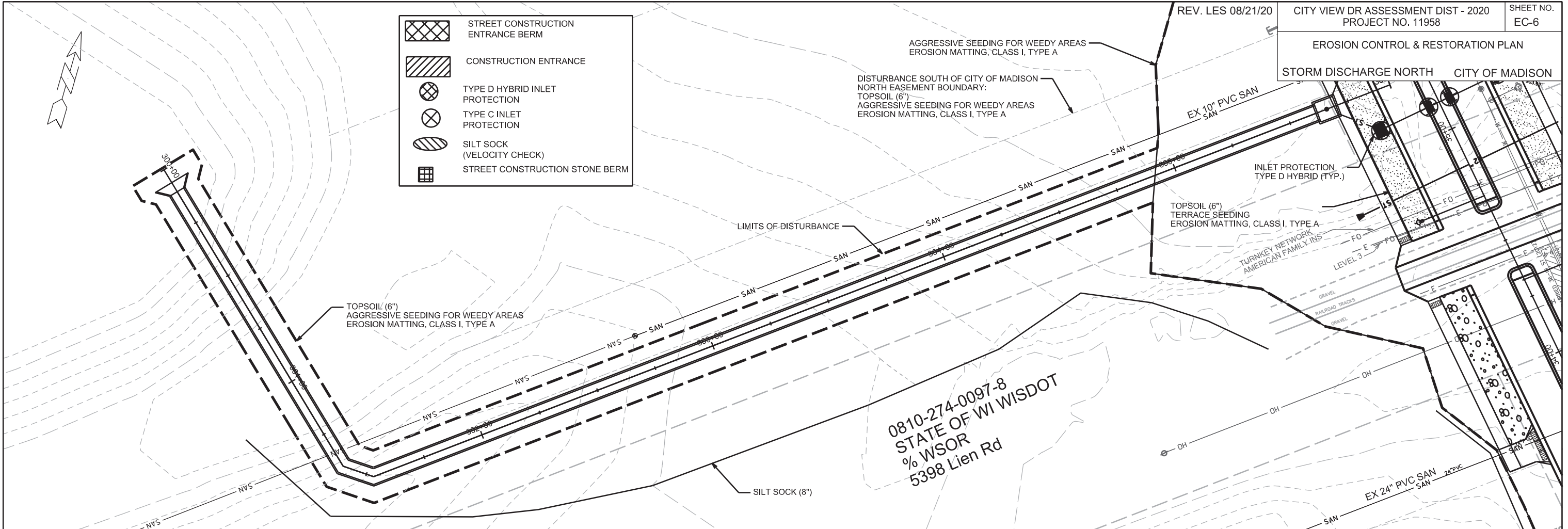

PLOT SCALE: _____

PLOT NAME: _____







REV. DATE: _____

ORIGINATOR: CITY OF MADISON, STREETS DIVISION

EROSION CONTROL & RESTORATION PLAN

LOT 68/69 EASEMENT CITY OF MADISON

REV 10/12/20 LES

-  STREET CONSTRUCTION ENTRANCE BERM
-  CONSTRUCTION ENTRANCE
-  TYPE D HYBRID INLET PROTECTION
-  TYPE C INLET PROTECTION
-  SILT SOCK (VELOCITY CHECK)
-  STREET CONSTRUCTION STONE BERM

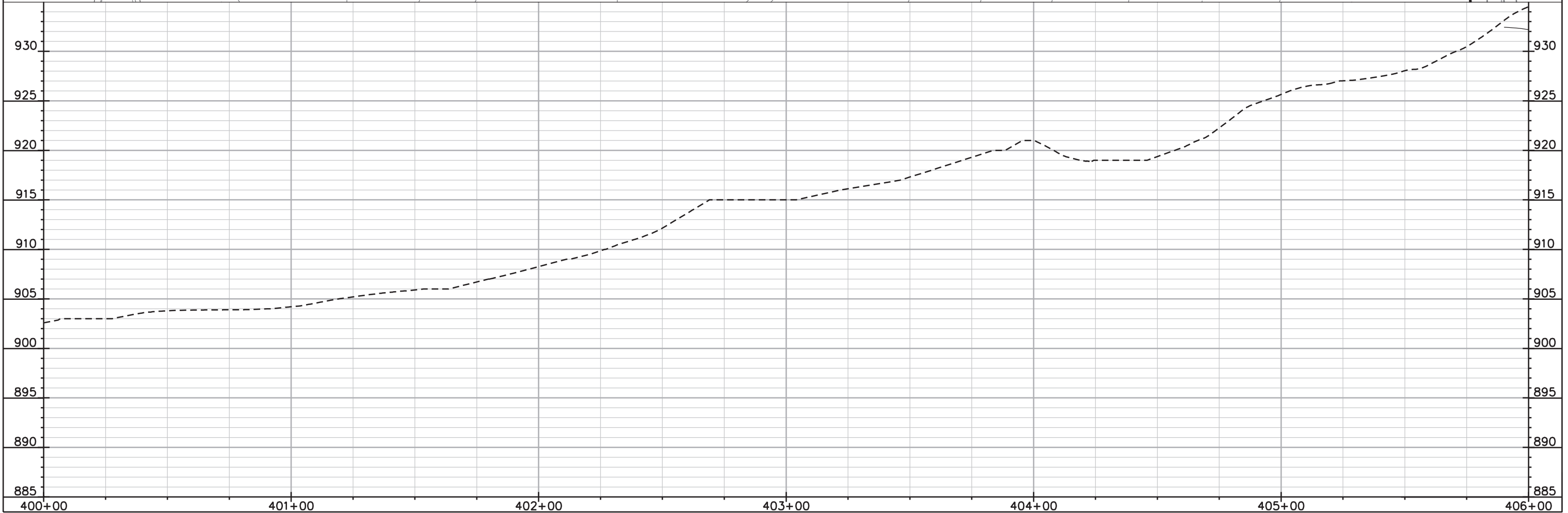
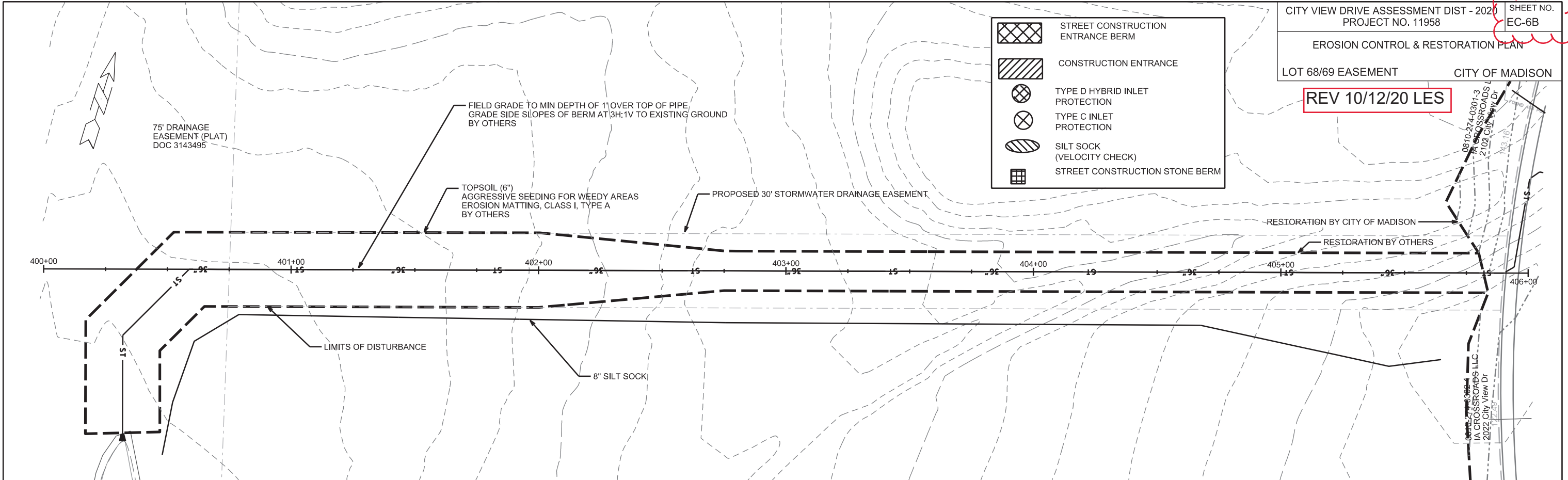

PLOT SCALE: _____

PLOT NAME: _____

REV. DATE: _____

ORIGINATOR: CITY OF MADISON, STREETS DIVISION

REV 10/12/20 LES

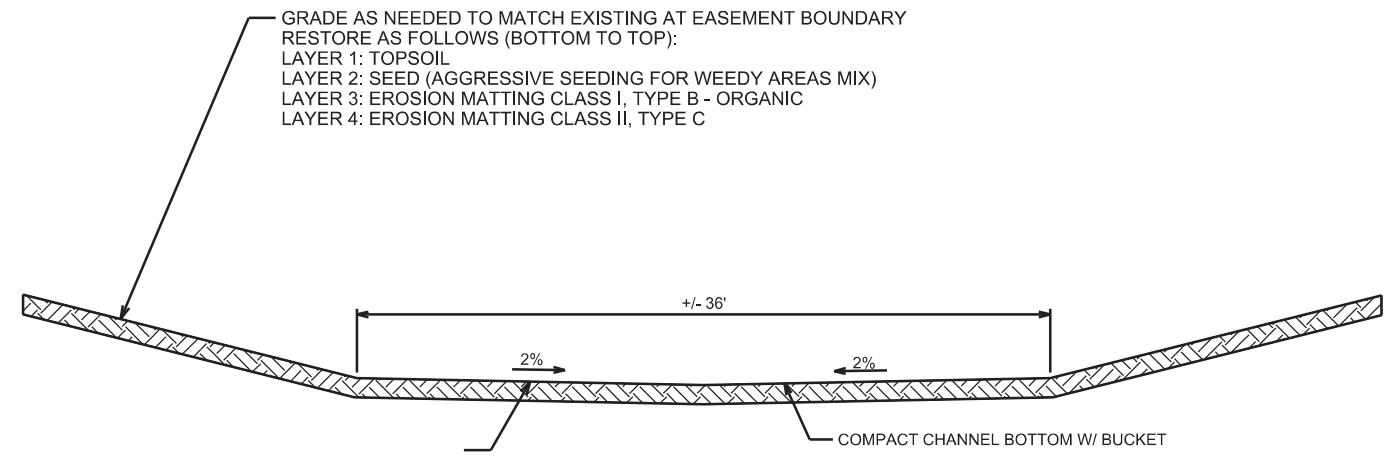

GRADE AT 2%
SLOPE TOWARDS CENTER OF CHANNEL
RESTORE AS FOLLOWS (BOTTOM TO TOP):
LAYER 1: TOPSOIL
LAYER 2: SEED (AGGRESSIVE SEEDING FOR WEEDY AREAS MIX)
LAYER 3: EROSION MATTING CLASS I, TYPE B - ORGANIC
LAYER 4: EROSION MATTING CLASS II, TYPE C

GRADE AS NEEDED TO MATCH EXISTING AT EASEMENT BOUNDARY
RESTORE AS FOLLOWS (BOTTOM TO TOP):
LAYER 1: TOPSOIL
LAYER 2: SEED (AGGRESSIVE SEEDING FOR WEEDY AREAS MIX)
LAYER 3: EROSION MATTING CLASS I, TYPE B - ORGANIC
LAYER 4: EROSION MATTING CLASS II, TYPE C

RESTORATION DETAIL
STA 100+00.00 TO 101+41.20
NOT TO SCALE

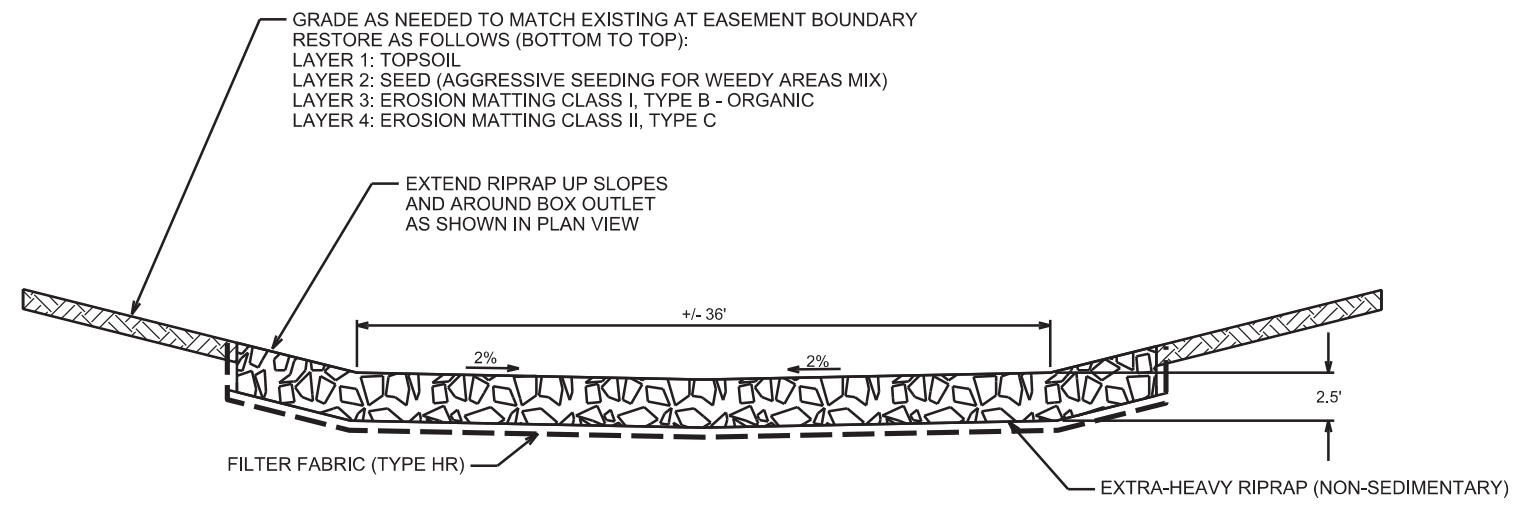

GRADE AS NEEDED TO MATCH EXISTING AT EASEMENT BOUNDARY
RESTORE AS FOLLOWS (BOTTOM TO TOP):
LAYER 1: TOPSOIL
LAYER 2: SEED (AGGRESSIVE SEEDING FOR WEEDY AREAS MIX)
LAYER 3: EROSION MATTING CLASS I, TYPE B - ORGANIC
LAYER 4: EROSION MATTING CLASS II, TYPE C

EXTEND RIPRAP UP SLOPES
AND AROUND BOX OUTLET
AS SHOWN IN PLAN VIEW

FILTER FABRIC (TYPE HR)

EXTRA-HEAVY RIPRAP (NON-SEDIMENTARY)

RESTORATION DETAIL
STA 101+41.20 TO 101+71.20
NOT TO SCALE

PLOT SCALE: _____

PLOT NAME: _____

REV. DATE: _____

ORIGINATOR: CITY OF MADISON, STREETS DIVISION

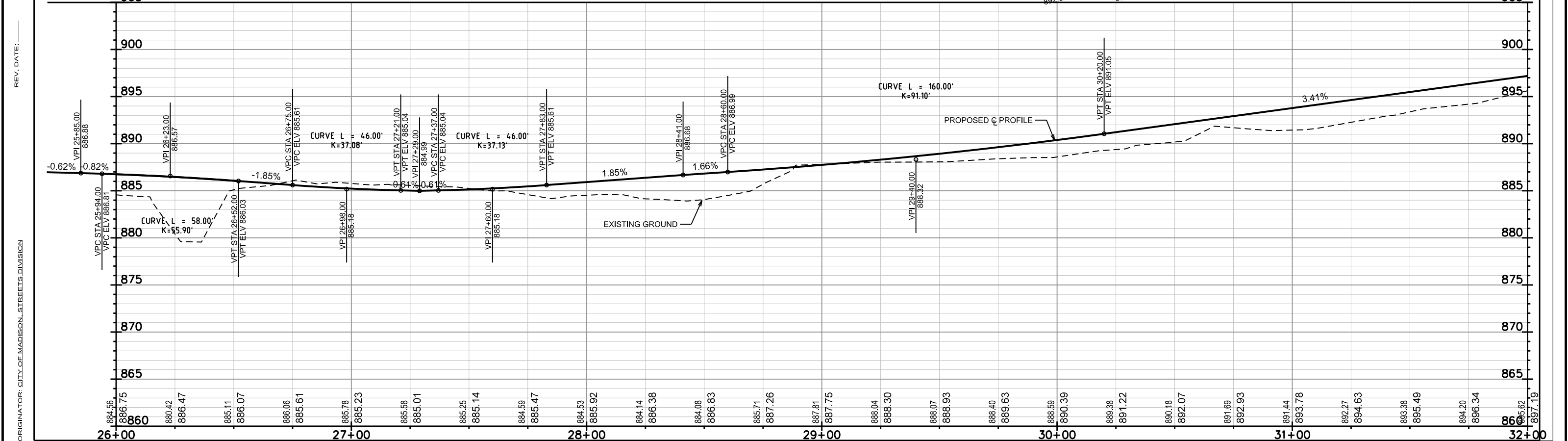
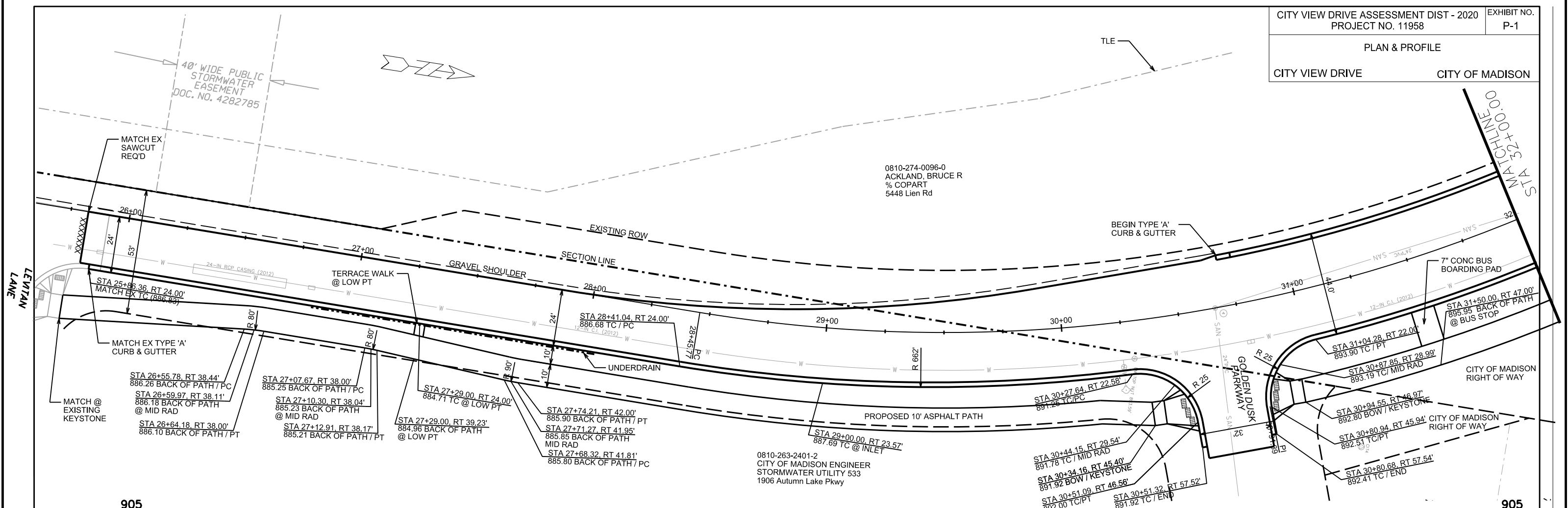

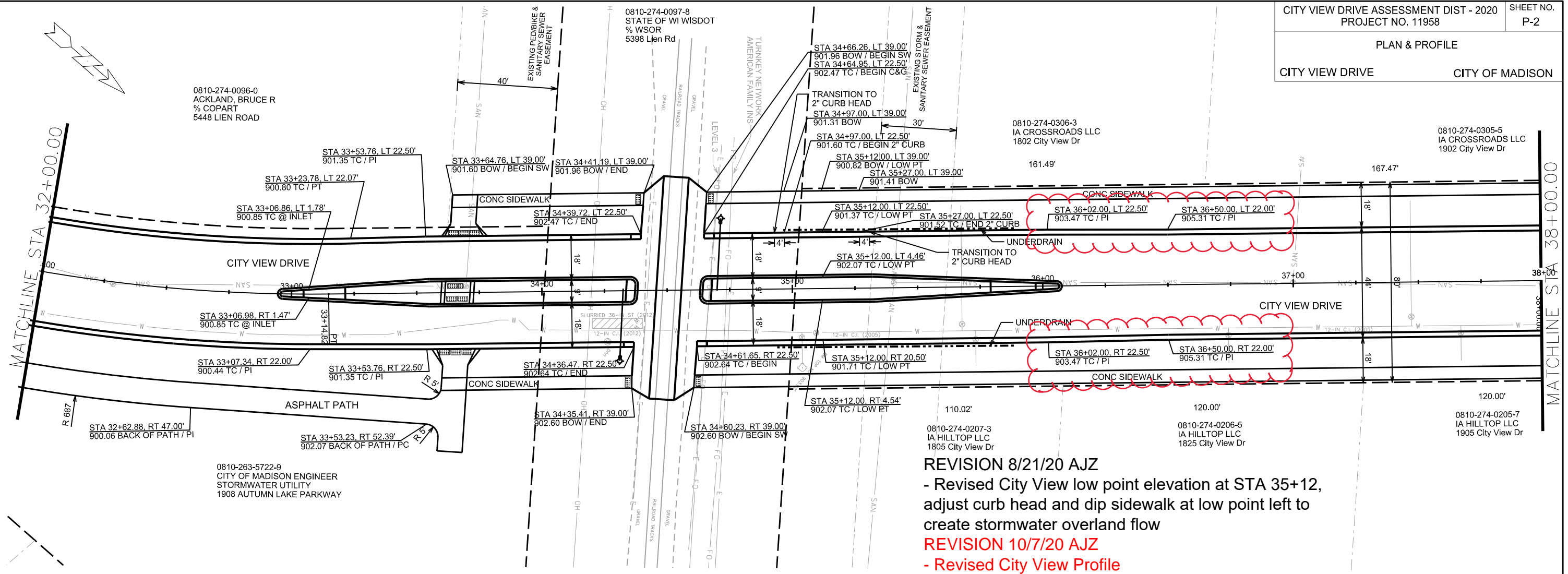

REVISION 8/21/20 AJZ
 - Revised City View low point elevation at STA 35+12, adjust curb head and dip sidewalk at low point left to create stormwater overland flow

REVISION 10/7/20 AJZ
 - Revised City View Profile

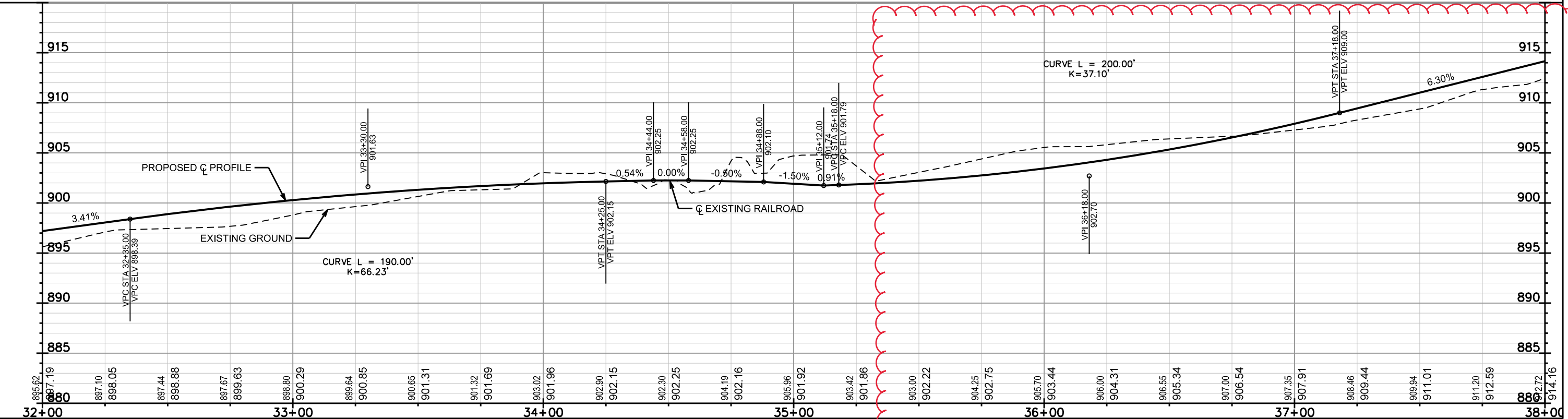

PLOT SCALE: _____

PLOT NAME: _____

REV. DATE: _____

ORIGINATOR: CITY OF MADISON, STREETS DIVISION

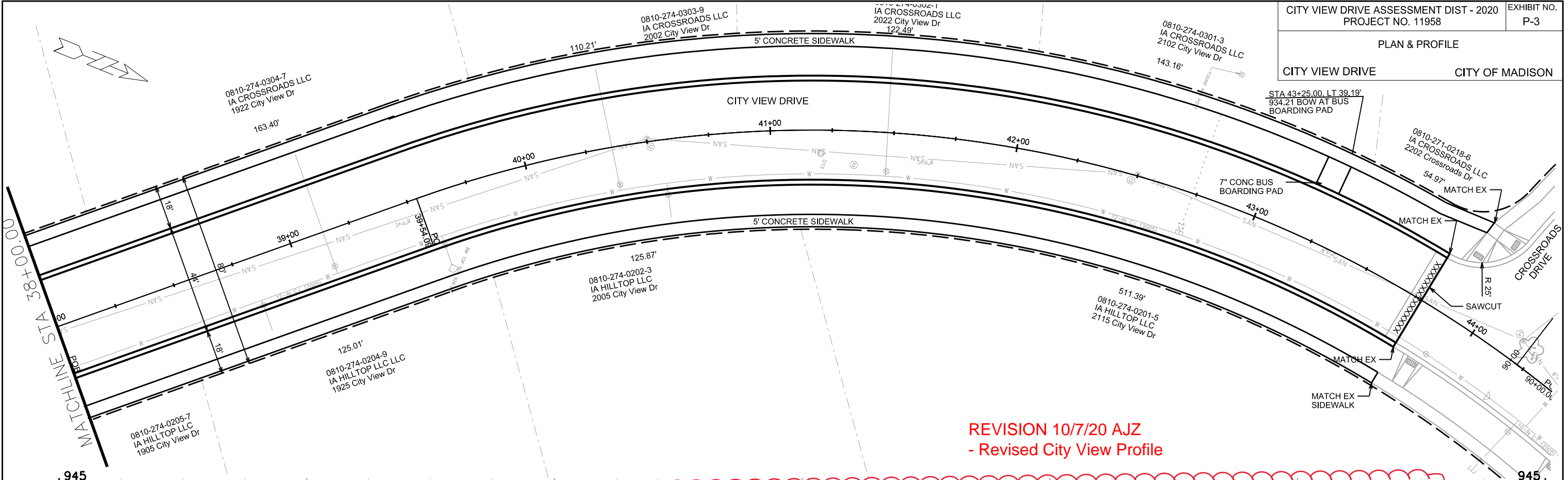

REVISION 10/7/20 AJZ
- Revised City View Profile

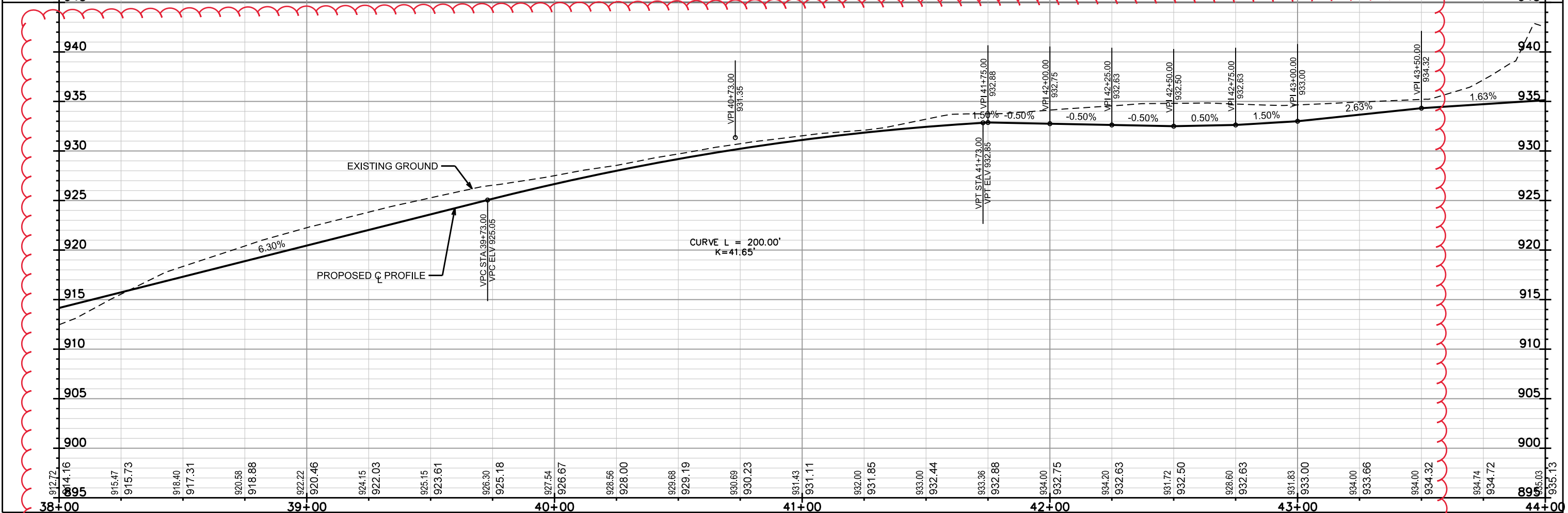

PLOT SCALE: _____

REV. DATE: _____

ORIGINATOR: CITY OF MADISON, STREET'S DIVISION

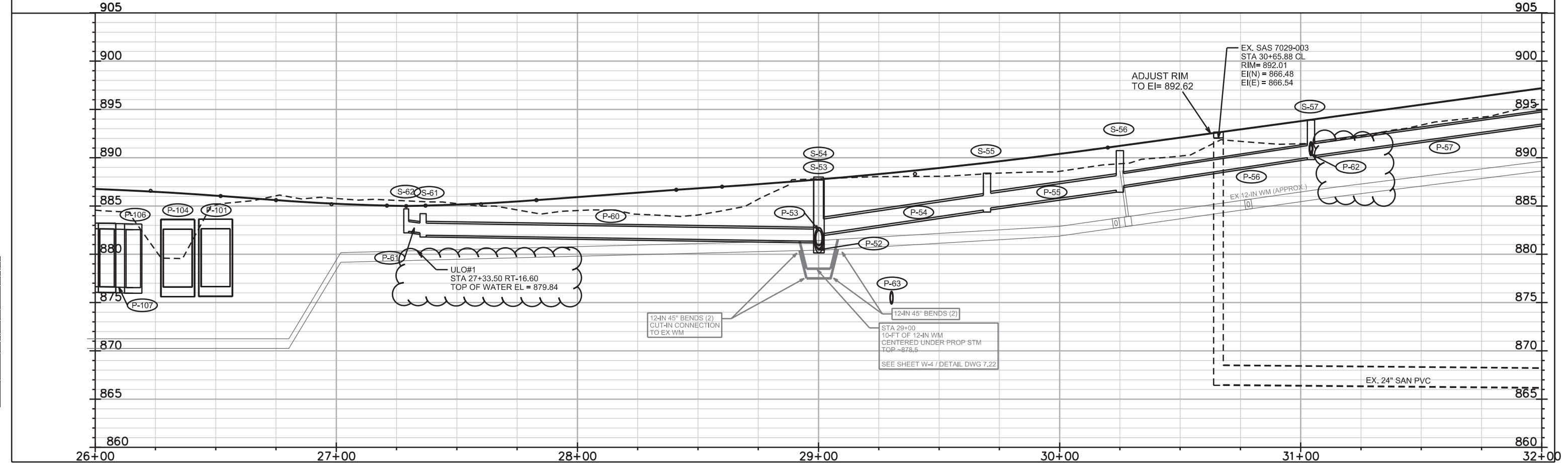
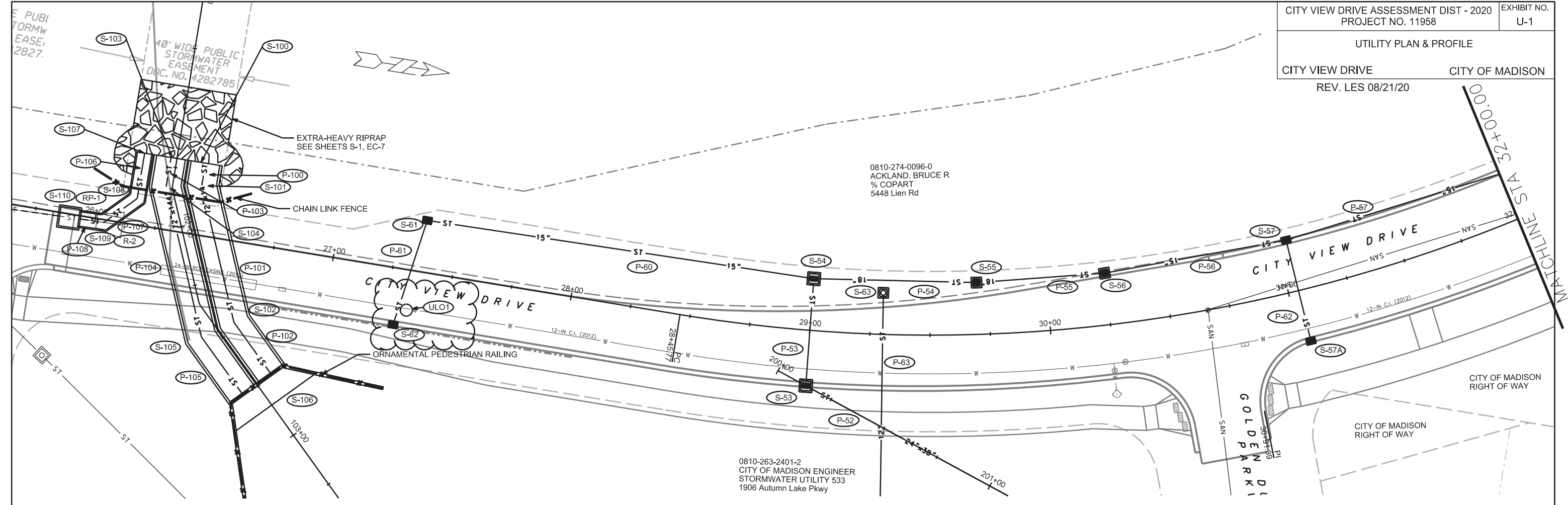

REV. DATE: _____

ORIGINATOR: CITY OF MADISON, STREETS DIVISION

REV 10/7/20 LES

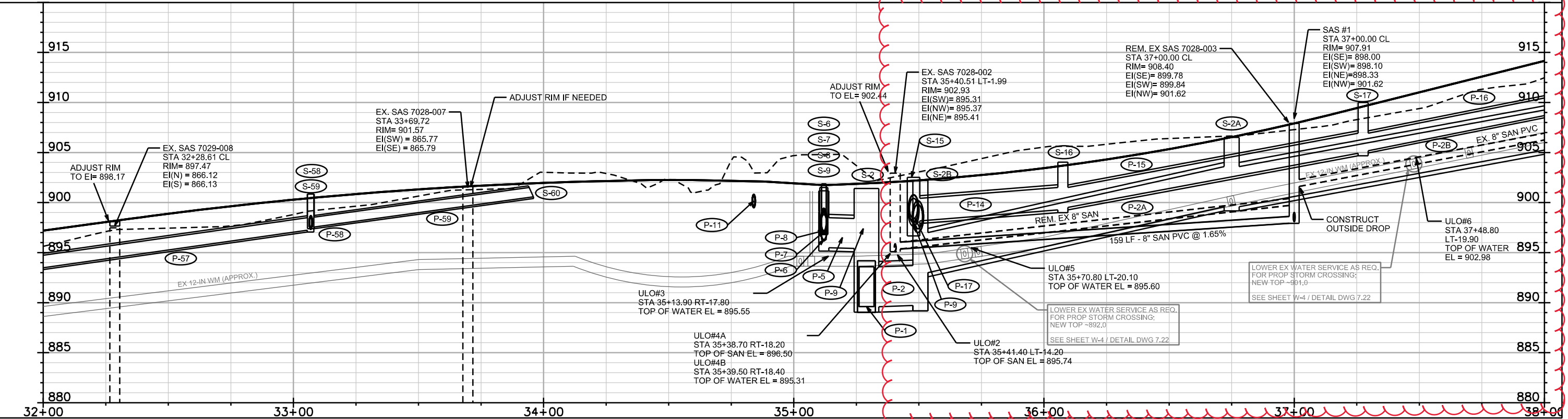
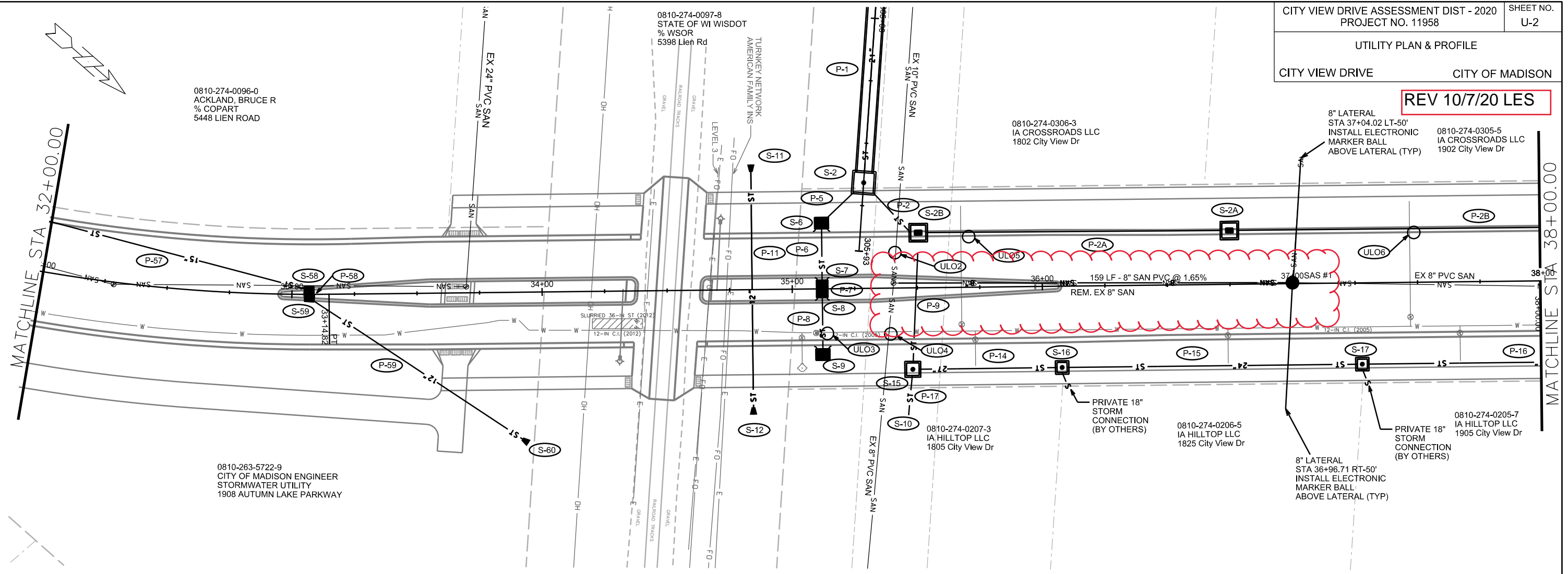

PLOT SCALE: _____

REV. DATE: _____

ORIGINATOR: CITY OF MADISON, STREETS DIVISION

REV 10/7/20 LES

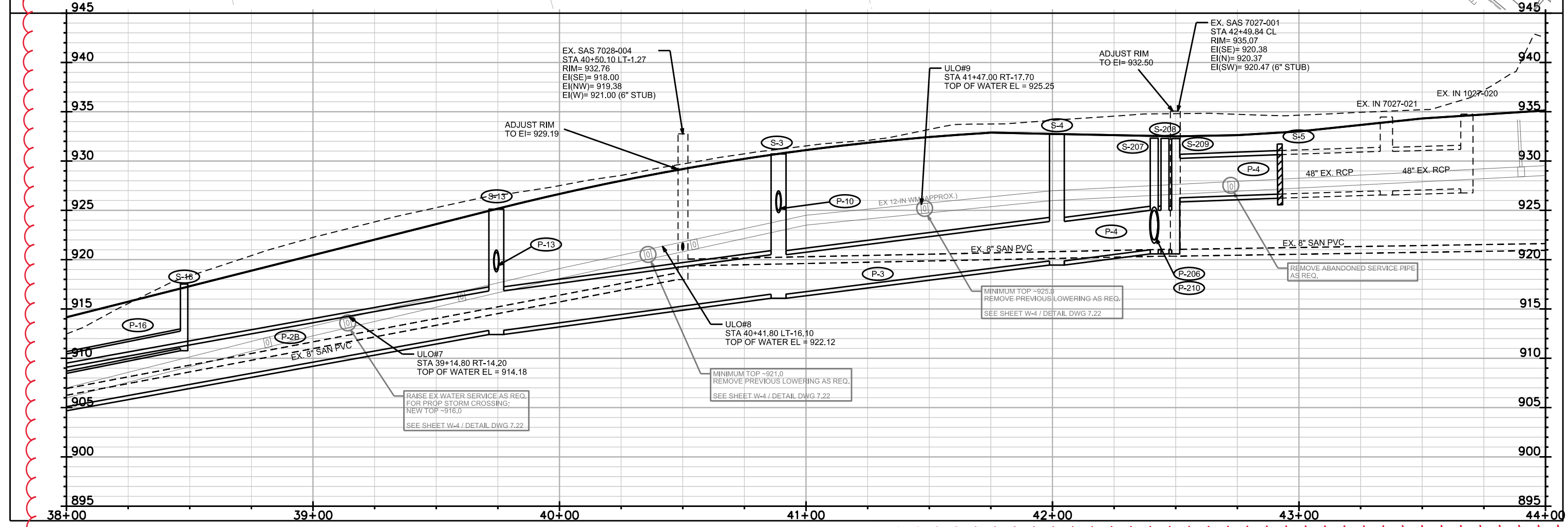
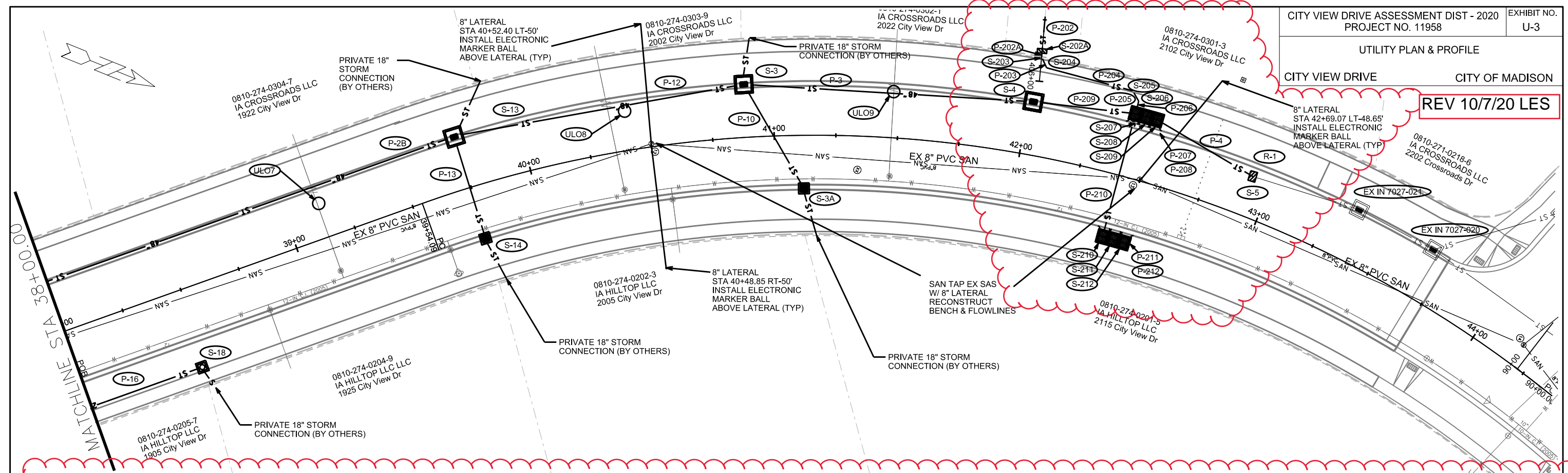

PLOT SCALE: _____

REV. DATE: _____

ORIGINATOR: CITY OF MADISON, STREETS DIVISION

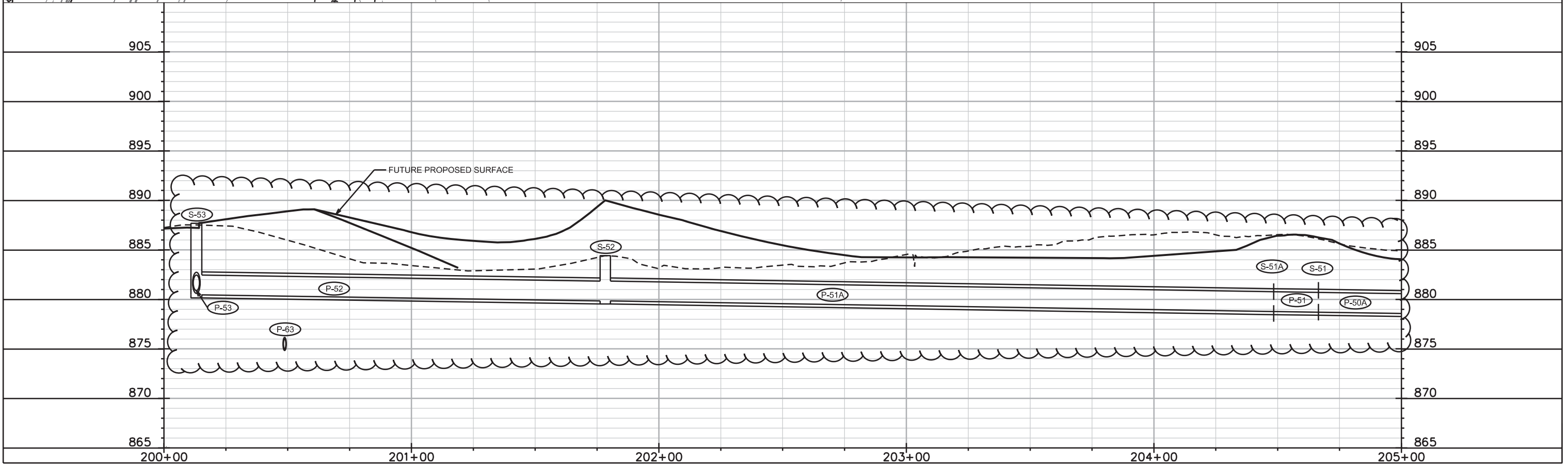
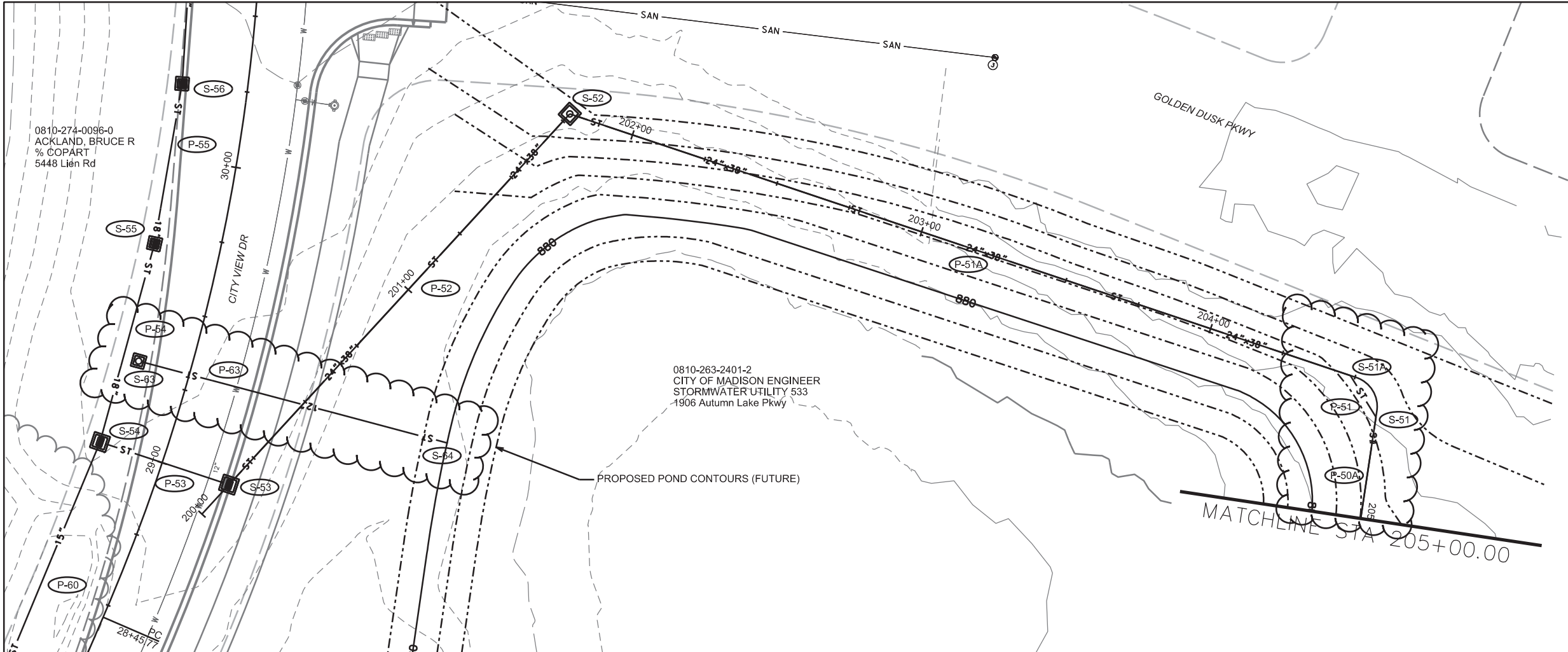

PLOT SCALE: _____
 PLOT NAME: _____
 REV. DATE: _____
 ORIGINATOR: CITY OF MADISON, STREETS DIVISION

PLAN AND PROFILE
STORM DISCHARGE - SOUTH CITY OF MADISON
REV 7/9/20 LES

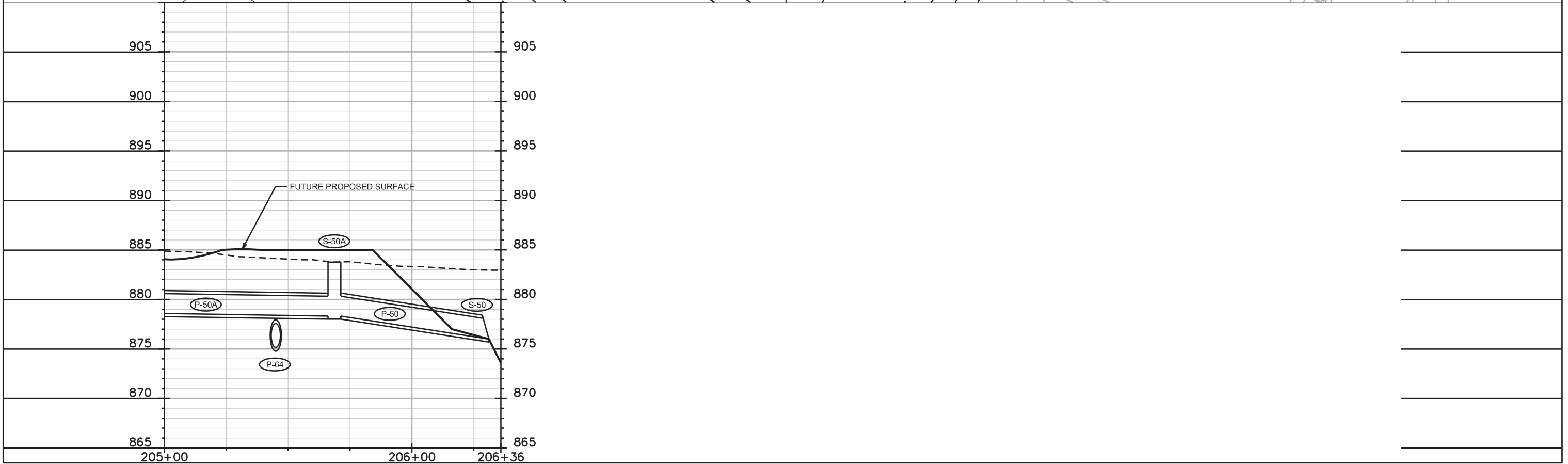
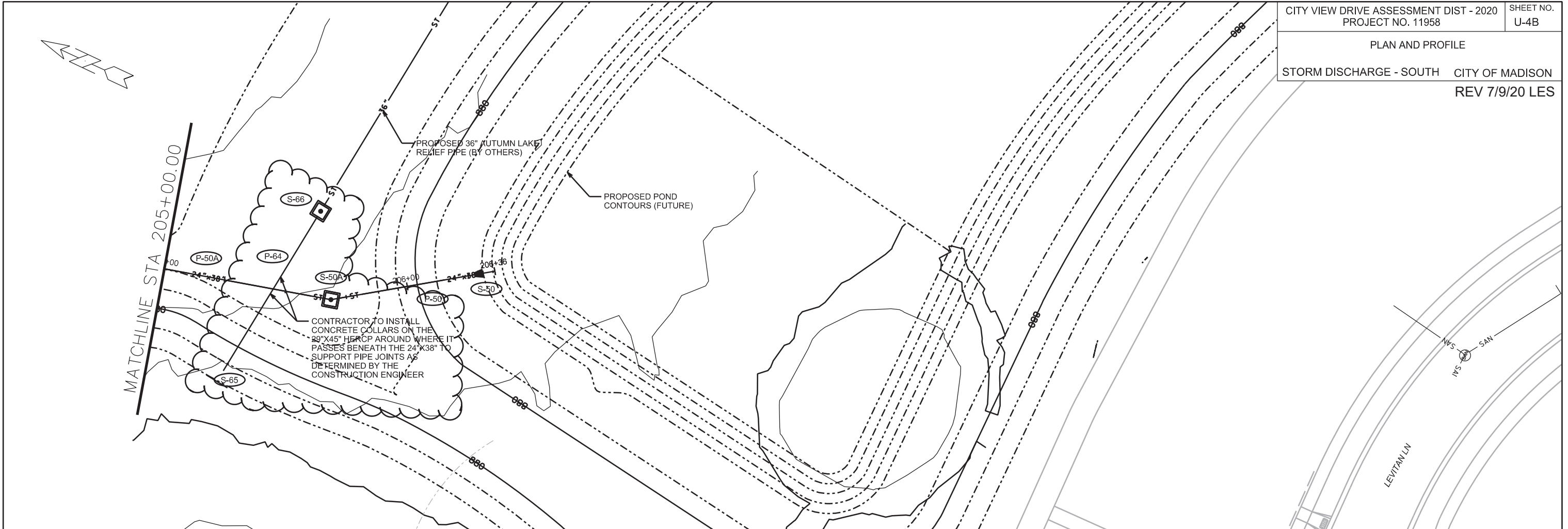

PLOT SCALE: _____

PLOT NAME: _____

REV. DATE: _____

ORIGINATOR: CITY OF MADISON, STREETS DIVISION

UTILITY PLAN AND PROFILE
STORM DISCHARGE NORTH CITY OF MADISON

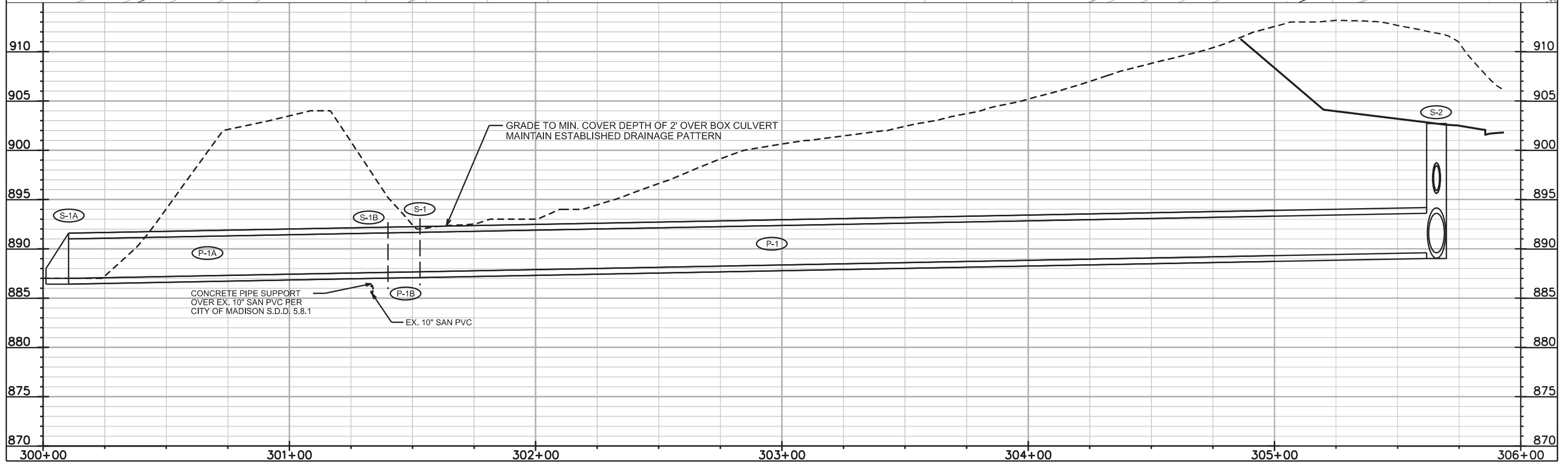
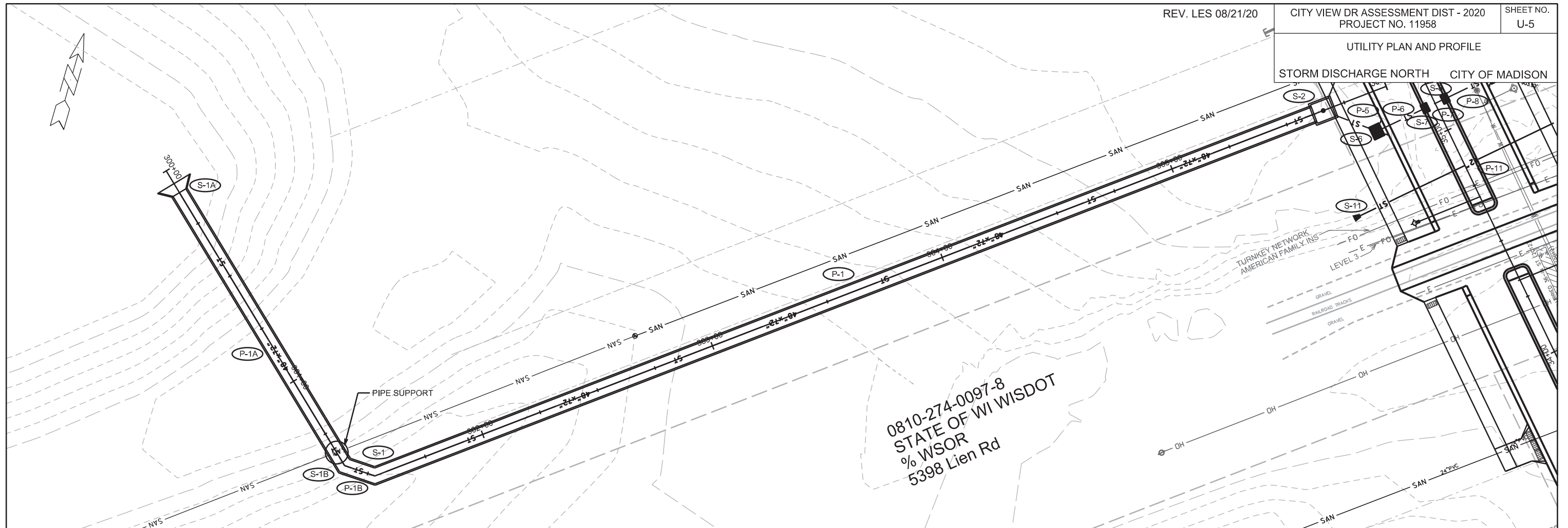

PLOT SCALE: _____

PLOT NAME: _____

REV. DATE: _____

ORIGINATOR: CITY OF MADISON, STREETS DIVISION

PLAN AND PROFILE

LOT 68/69 EASEMENT CITY OF MADISON

REV 10/12/20 LES

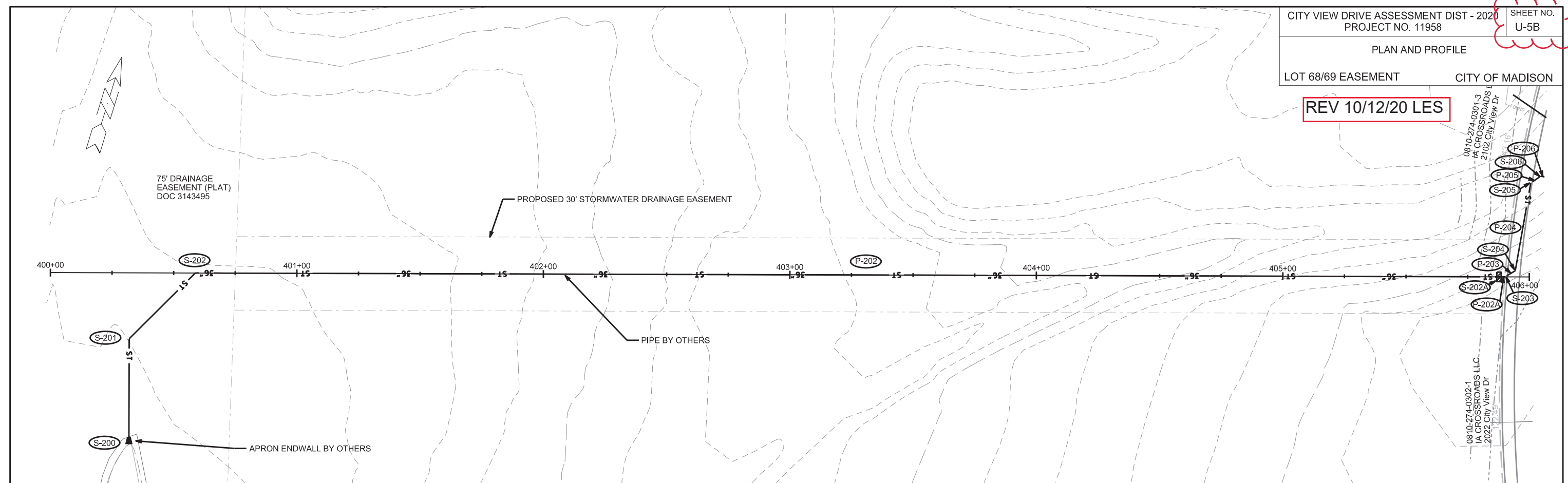

PLOT SCALE: _____

REV. DATE: _____

ORIGINATOR: CITY OF MADISON, STREETS DIVISION

STORM SEWER SCHEDULE

*REV 8/21/20 LES

CITY VIEW DRIVE ASSESSMENT DIST - 2020	SHEET NO. U-6
PROJECT NO. 11958	
STORM SEWER SCHEDULE	
CITY OF MADISON	

PROPOSED STORM STRUCTURES

STRUC. NO.	STATION	LOCATION (OFFSET)	TYPE	TOP OF CASTING	E.I.	DEPTH	NOTES
S-50	206+31.14	CL	24"X38" HERCP AE W/ GATE	-	876.00	-	SEE SDD 5.4.3 AND 5.6.1
S-50A	205+68.69	CL	5X5 SAS	883.77	878.32	5.45	W/ R-1550-0054
S-51	204+66.47	CL	PRECAST 24"X38" HERCP 40° BEND	-	878.71	-	SEE STANDARD SPECS, ART. 504
S-51A	204+48.40	CL	PRECAST 24"X38" HERCP 40° BEND	-	878.77	-	SEE STANDARD SPECS, ART. 504
S-52	201+78.31	CL	4X4 SAS	884.42	879.85	4.57	W/ R-1550-0054
S-53	29+00.00	RT-23.07	4X4 SAS	887.69	880.46	7.23	W/ R-3067-7004-V
S-54	29+00.00	LT-21.50	4X4 SAS	888.00	881.03	6.97	W/ R-1878-B7L
S-55	29+69.88	LT-21.50	3X3 SAS	888.40	884.69	3.71	W/ R-1878-B7L
S-56	30+25.00	LT-21.50	3X3 SAS	890.74	886.74	4.00	W/ R-1878-B7L
* S-57	31+04.21	LT-21.50	H INLET	893.90	890.11	3.79	FP OR 3X3; W/ R-3067-7004-V
S-57A	31+04.28	RT-21.50	H INLET	893.90	890.57	3.33	W/ R-3067-7004-V
S-58	33+06.86	LT-1.78	H INLET	900.85	897.50	3.35	FP; W/ R-3067-7004-V
S-59	33+06.98	RT-1.47	H INLET	900.85	897.55	3.30	W/ R-3067-7004-V
S-60	33+93.94	RT-60.34	12" AE W/ GATE	-	900.50	-	SEE SDD 5.4.1 AND 5.6.1
S-61	27+36.00	LT-21.50	H INLET	884.20	881.97	2.23	FP; W/ R-1878-B7L
S-62	27+29.00	RT-23.50	H INLET	884.71	882.38	2.33	FP; W/ R-3067-7004-V
S-63	29+30.03	LT-17.22	3X3 SAS	888.13	875.00	13.13	W/ R-1550-0054
S-64	29+31.57	RT-87.71	PIPE PLUG	-	875.00	-	W/ ELECTRONIC MARKER BALL
S-65	205+31.18	RT-36.24	PIPE PLUG	-	875.03	-	W/ ELECTRONIC MARKER BALL
S-66	205+58.10	LT-34.39	5X5 SAS	884.62	875.27	9.35	W/ R-1550-0054

PROPOSED STORM PIPES

PIPE	FROM	TO	DISCH.	INLET	PLAN (PAY)	PIPE	SLOPE	PIPE	TYPE	NOTES
P-50	S-50	S-50A	876.00	878.32	62	60	3.88%	24"X38"	HERCP	
P-50A	S-50A	S-51	878.32	878.71	102	100	0.39%	24"X38"	HERCP	
P-51	S-51	S-51A	878.71	878.77	16	16	0.38%	24"X38"	HERCP	
P-51A	S-51A	S-52	878.77	879.85	270	268	0.40%	24"X38"	HERCP	
P-52	S-52	S-53	879.85	880.46	165	161	0.38%	24"X38"	HERCP	
P-53	S-53	S-54	880.88	881.03	45	41	0.38%	19"X30"	HERCP	
P-54	S-54	S-55	882.00	884.69	67	64	4.20%	18"	RCP	
P-55	S-55	S-56	884.69	886.74	50	53	3.85%	18"	RCP	
P-56	S-56	S-57	886.99	890.11	77	74	4.25%	15"	RCP	
P-57	S-57	S-58	890.11	897.25	199	196	3.64%	15"	RCP	
P-58	S-58	S-59	897.50	897.55	3	1	4.00%	12"	RCP	
P-59	S-59	S-60	897.55	900.50	105	103	2.86%	12"	RCP	
P-60	S-54	S-61	881.36	881.97	162	159	0.38%	15"	RCP	
P-61	S-61	S-62	882.22	882.38	46	43	0.38%	12"	RCP	
P-62	S-57	S-57A	890.36	890.57	43	41	0.50%	12"	RCP	
P-63	S-63	S-64	875.00	875.00	105	103	0.00%	12"	RCP	
P-64	S-65	S-66	875.03	875.27	76	73	0.33%	29"X45"	HERCP	

NOTE: PLAN LENGTH (PAY LENGTH) IS FROM CENTER OF STRUCTURE TO CENTER OF STRUCTURE. PIPE LENGTH IS ACTUAL LENGTH OF PIPE FROM STRUCTURE WALL TO STRUCTURE WALL. SLOPE CALCULATED USING PIPE LENGTH.

REMOVE SEWER STRUCTURES

STRUC. NO.	ID NO.	STATION	LOCATION (OFFSET)	TYPE	PAID (Y/N)
R-2	AE 7129-020	26+11.53	RT-0.97	54" AE W/ GATE	N

REMOVE SEWER PIPES

REMOVE NO.	REMOVE FROM	REMOVE TO	LGTH (FT)	PIPE SIZE	PIPE TYPE	PAID (Y/N)	NOTES
RP-1	AE 7129-020	25+89.24 RT-1.43	22.3	54"	RCP	N	

STANDARD NOTES:

-PLAN LENGTH (PAY LENGTH) IS FROM CENTER OF STRUCTURE TO CENTER OF STRUCTURE. PIPE LENGTH IS ACTUAL LENGTH OF PIPE FROM STRUCTURE WALL TO STRUCTURE WALL. SLOPE CALCULATED USING PIPE LENGTH.

-KOR N SEAL BOOTS OR EQUIVALENT SHALL BE USED FOR ALL PIPE CONNECTIONS TO INLETS. IN ADDITION, KOR N SEAL BOOTS SHALL BE REQUIRED FOR ANY TYPE II PIPE CONNECTIONS TO SAS STORM STRUCTURES. CONCRETE COLLARS OR KOR N SEAL MAY BE USED FOR ANY RCP OR HERCP CONNECTIONS TO SAS STORM STRUCTURES.

-ALL REBAR FOR FIELD Poured STRUCTURES SHALL BE EPOXY COATED. ANY EXPOSED STEEL SHALL BE TOUCHED UP OR RECOATED PRIOR TO USE.

-ALL FIELD Poured SAS STORM STRUCTURES SHALL BE CONSTRUCTED IN ACCORDANCE WITH STANDARD DETAIL DRAWING 5.7.3. ALL PRECAST SAS STORM STRUCTURES SHALL BE CONSTRUCTED IN ACCORDANCE WITH STANDARD DETAIL DRAWING 5.7.5.

- ABBREVIATIONS: AE = APRON ENDWALL; RCP = REINFORCED CONCRETE PIPE; HERCP = HORIZONTAL ELLIPTICAL REINFORCED CONCRETE PIPE; DNA = DOES NOT APPLY; SAS = SEWER ACCESS STRUCTURE; LP = LOW POINT INLET STRUCTURE; FP = FIELD Poured STRUCTURE; TR = TOP OF CONCRETE ROOF; NCM = NO CROWN MATCH FOR PIPES; UD = UNDERDRAIN

- APPROXIMATE DISCHARGE E.I. GIVEN, ADJUST E.I. AND PIPE SLOPE IN THE FIELD.

- TOP OF CASTING GRADE GIVEN IS THE TOP OF CURB FOR INLET STRUCTURES AND THE FLOWLINE OF THE CLOSED CASTING FOR SAS'S.

- ALL REINFORCED CONCRETE PIPES TO BE CLASS III UNLESS OTHERWISE NOTED.

- SURVEYOR TO CONFIRM THAT ALL INLET STATION / OFFSETS LINE UP WITH PROPOSED CURB AND GUTTER.

- ALL STRUCTURES CALLED OUT AS FIELD Poured SHALL BE FIELD Poured. ALL OTHER STRUCTURES (NOT INDICATED AS FIELD Poured) SHALL BE SUBMITTED TO CITY ENGINEERING FOR APPROVAL IF PRECAST STRUCTURES ARE NOT PREFERRED. CONTACT LAUREN STRIEGL OF CITY ENGINEERING AT (608) 266-4094 FOR PRECAST APPROVALS, FAX SHOP DRAWINGS TO (608)264-9275, OR EMAIL SHOP DRAWINGS TO LSTRIEGL@CITYOFMADISON.COM.

STORM SEWER SCHEDULE

PROPOSED STORM STRUCTURES

STRUC. NO.	STATION	LOCATION (OFFSET)	TYPE	TOP OF CASTING	E.I.	DEPTH	NOTES
S-100	101+71.20	LT-12.00	RCBC CUTOFF WALL	-	876.39	-	FP; SEE SHEET S-2 IN PLAN SET
S-101	101+80.51	LT-12.00	PRECAST 12X6 RCBC 22.5° BEND	-	876.51	-	-
S-102	102+47.49	LT-7.25	PRECAST 12X6 RCBC 22.5° BEND	-	876.85	-	-
S-103	101+71.19	RT-2.50	RCBC CUTOFF WALL	-	876.39	-	FP; SEE SHEET S-2 IN PLAN SET
S-104	101+83.10	RT-2.55	PRECAST 12X6 RCBC 22.5° BEND	-	876.51	-	-
S-105	102+44.60	RT-7.25	PRECAST 12X6 RCBC 22.5° BEND	-	876.84	-	-
S-106	102+74.09	CL	CAST-IN-PLACE WINGWALLS AND APRON	-	877.00	-	FP; SEE SHEET S-4 IN PLAN SET
S-107	101+71.18	RT-13.58	RCBC CUTOFF WALL W/ OUTLET GATE	-	876.39	-	SEE SPEC. NOTE 2
S-108	101+84.57	RT-15.14	PRECAST 6X6 RCBC 45° BEND	-	876.55	-	-
S-109	101+91.07	RT-30.81	PRECAST 6X6 RCBC 45° BEND	-	876.63	-	-
S-110	101+85.78	RT-44.37	STORM SAS - SPECIAL	886.84	876.69	10.15	W/ R-1550-0054; SEE SHEET S-6

PROPOSED STORM PIPES

PIPE	FROM	TO	DISCH.	INLET	PLAN (PAY)	PIPE	SLOPE	PIPE	TYPE	NOTES
P-100	S-100	S-101	876.45	876.51	9	9	0.65%	12'X6'	RCBC	
P-101	S-101	S-102	876.51	876.85	58	58	0.58%	12'X6'	RCBC	
P-102	S-102	S-106	876.85	877.00	27	27	0.56%	12'X6'	RCBC	
P-103	S-103	S-104	876.45	876.51	12	12	0.49%	12'X6'	RCBC	
P-104	S-104	S-105	876.51	876.84	64	64	0.51%	12'X6'	RCBC	
P-105	S-105	S-106	876.84	877.00	29	29	0.54%	12'X6'	RCBC	
P-106	S-107	S-108	876.45	876.55	19	19	0.52%	6'X6'	RCBC	
P-107	S-108	S-109	876.55	876.63	17	17	0.52%	6'X6'	RCBC	
P-108	S-109	S-110	876.63	876.69	15	11	0.52%	6'X6'	RCBC	

CITY OF MADISON

UTILITY LINE OPENINGS (ULO)

ULO NO.	STATION NO.	LOCATION (OFFSET)	TYPE	TOP ELEV.	NOTES
* ULO1	27+33.50	RT-16.60	WATER	879.84	
* ULO2	35+41.40	LT-14.20	SANITARY	895.74	
* ULO3	35+13.90	RT-17.80	WATER	895.55	
* ULO4A	35+38.70	RT-18.20	SANITARY	896.50	
* ULO4B	35+39.50	RT-18.40	WATER	895.31	
* ULO5	35+70.80	LT-20.10	WATER	895.60	
* ULO6	37+48.80	LT-19.90	WATER	902.98	
* ULO7	39+14.80	RT-14.20	WATER	914.18	
* ULO8	40+41.80	LT-16.10	WATER	922.12	
* ULO9	41+47.00	RT-17.70	WATER	925.25	

NOTE: PLAN LENGTH (PAY LENGTH) IS FROM CENTER OF STRUCTURE TO CENTER OF STRUCTURE. PIPE LENGTH IS ACTUAL LENGTH OF PIPE FROM STRUCTURE WALL TO STRUCTURE WALL. SLOPE CALCULATED USING PIPE LENGTH.

SPECIFIC NOTES

(2) FP; SEE SHEET S-2 IN PLAN SET AND SDD 5.6.3

STANDARD NOTES:

- PLAN LENGTH (PAY LENGTH) IS FROM CENTER OF STRUCTURE TO CENTER OF STRUCTURE. PIPE LENGTH IS ACTUAL LENGTH OF PIPE FROM STRUCTURE WALL TO STRUCTURE WALL. SLOPE CALCULATED USING PIPE LENGTH.
- KOR N SEAL BOOTS OR EQUIVALENT SHALL BE USED FOR ALL PIPE CONNECTIONS TO INLETS. IN ADDITION, KOR N SEAL BOOTS SHALL BE REQUIRED FOR ANY TYPE II PIPE CONNECTIONS TO SAS STORM STRUCTURES. CONCRETE COLLARS OR KOR N SEAL MAY BE USED FOR ANY RCP OR HERCP CONNECTIONS TO SAS STORM STRUCTURES.
- ALL REBAR FOR FIELD POURED STRUCTURES SHALL BE EPOXY COATED. ANY EXPOSED STEEL SHALL BE TOUCHED UP OR RECOATED PRIOR TO USE.
- ALL FIELD POURED SAS STORM STRUCTURES SHALL BE CONSTRUCTED IN ACCORDANCE WITH STANDARD DETAIL DRAWING 5.7.3. ALL PRECAST SAS STORM STRUCTURES SHALL BE CONSTRUCTED IN ACCORDANCE WITH STANDARD DETAIL DRAWING 5.7.5.

- ABBREVIATIONS: AE = APRON ENDWALL; RCP = REINFORCED CONCRETE PIPE; HERCP = HORIZONTAL ELLIPTICAL REINFORCED CONCRETE PIPE; DNA = DOES NOT APPLY; SAS = SEWER ACCESS STRUCTURE; LP = LOW POINT INLET STRUCTURE; FP = FIELD POURED STRUCTURE; TR = TOP OF CONCRETE ROOF; NCM = NO CROWN MATCH FOR PIPES; UD = UNDERDRAIN
- APPROXIMATE DISCHARGE E.I. GIVEN, ADJUST E.I. AND PIPE SLOPE IN THE FIELD.
- TOP OF CASTING GRADE GIVEN IS THE TOP OF CURB FOR INLET STRUCTURES AND THE FLOWLINE OF THE CLOSED CASTING FOR SAS's.
- ALL REINFORCED CONCRETE PIPES TO BE CLASS III UNLESS OTHERWISE NOTED.
- SURVEYOR TO CONFIRM THAT ALL INLET STATION / OFFSETS LINE UP WITH PROPOSED CURB AND GUTTER.
- ALL STRUCTURES CALLED OUT AS FIELD POURED SHALL BE FIELD POURED. ALL OTHER STRUCTURES (NOT INDICATED AS FIELD POURED) SHALL BE SUBMITTED TO CITY ENGINEERING FOR APPROVAL IF PRECAST STRUCTURES ARE PREFERRED. CONTACT LAUREN STRIEGL OF CITY ENGINEERING AT (608) 266-4094 FOR PRECAST APPROVALS, FAX SHOP DRAWINGS TO (608)264-9275, OR EMAIL SHOP DRAWINGS TO LSTRIEGL@CITYOFMADISON.COM.

STORM SEWER SCHEDULE

*REV 10/7/20 LES

PROPOSED STORM STRUCTURES

STRUC. NO.	STATION	LOCATION (OFFSET)	TYPE	TOP OF CASTING	E.I.	DEPTH	NOTES
S-1A	300+10.35	CL	6'X4' WINGWALL W/ GATE	-	887.00	-	SEE SDD 5.5.1A, 5.5.1B AND 5.6.3
S-1B	301+40.05	CL	PRECAST 6X4 RCBC 50° BEND	-	887.61	-	SEE BID ITEM 90034
S-1	301+53.05	CL	PRECAST 6X4 RCBC 50° BEND	-	887.67	-	SEE BID ITEM 90034
S-2	35+29.05	LT-42.22	10X10 SAS	901.41	889.60	11.81	FP; W/ R-1550-0054; SEE SPEC. NOTE 2
* S-2A	36+75.00	LT-21.50	6X6 SAS	906.51	899.59	6.92	FP; W/ R-3067-7004-V
* S-2B	35+50.61	LT-22.01	6X6 SAS	902.20	889.71	12.49	FP; W/ R-3067-7004-V
* S-3	40+88.87	LT-21.50	6X6 SAS	930.71	916.50	14.21	FP; W/ R-3067-7004-V
* S-3A	41+11.84	RT-21.50	3X3 SAS	931.46	926.67	4.79	W/ R-3067-7004-V
* S-4	42+01.80	LT-21.50	6X6 SAS	932.73	919.87	12.86	FP; W/ R-3067-7004-V
S-5	42+92.27	LT-16.39	CONCRETE COLLAR	-	926.65	-	SEE SDD 5.4.5
S-6	35+12.00	LT-26.25	TERRACE INLET TYPE 2	901.17	895.50	5.67	FP; SEE SDD 5.7.12A; SEE SPEC NOTE 1
S-7	35+12.00	LT-1.88	TERRACE INLET TYPE 3	901.87	896.55	5.32	FP; SEE SDD 5.7.12B; SEE SPEC NOTE 1
S-8	35+12.00	RT-1.96	TERRACE INLET TYPE 3	901.87	897.08	4.79	FP; SEE SDD 5.7.12B; SEE SPEC NOTE 1
S-9	35+12.00	RT-26.25	TERRACE INLET TYPE 2	901.51	897.19	4.32	FP; SEE SDD 5.7.12A; SEE SPEC NOTE 1
S-10	35+41.83	RT-58.84	STUB	-	898.90	-	PLUG STUB; W/ ELECTRONIC MARKER BALL
S-11	34+84.00	RT-50.00	12" AE W/ GATE	-	899.50	-	SEE SDD 5.4.1 AND 5.6.1
S-12	34+84.00	LT-50.00	12" AE W/ GATE	-	899.80	-	SEE SDD 5.4.1 AND 5.6.1
* S-13	39+74.39	LT-21.50	6X6 SAS	925.12	912.83	12.29	FP; W/ R-3067-7004-V
* S-14	39+74.39	RT-21.50	3X3 SAS	925.12	920.33	4.79	W/ R-3067-7004-V
* S-15	35+47.86	RT-32.57	5X5 SAS	902.53	898.00	4.53	FP; W/ R-1550-0054
* S-16	36+07.56	RT-32.50	4X4 SAS	904.03	899.26	4.77	W/ R-1550-0054
* S-17	37+27.57	RT-32.50	4X4 SAS	910.00	904.93	5.07	W/ R-1550-0054
* S-18	38+47.72	RT-32.50	3X3 SAS	917.53	911.00	6.53	W/ R-1550-0054
* S-200	400+32.04	RT-69.54	36" AE W/ GATE	-	900.00	-	BY OTHERS
* S-201	400+32.04	RT-26.72	36" TYPE II STORM 45° BEND	-	901.42	-	BY OTHERS
* S-202	400+58.77	CL	36" TYPE II STORM 45° BEND	-	902.67	-	BY OTHERS
* S-202A	405+87.67	CL	STUB	-	920.28	-	W/ TEMP PLUG; W/ ELECTRONIC MARKER BALL
* S-203	405+90.09	CL	36" TYPE II STORM 45° BEND	-	920.36	-	
* S-204	405+94.28	LT-2.43	36" TYPE II STORM 45° BEND	-	920.52	-	
* S-205	42+38.06	LT-34.49	36" TYPE II STORM 45° BEND	-	921.72	-	
* S-206	42+41.28	LT-31.02	36" TYPE II STORM 45° BEND	-	921.88	-	
* S-207	42+41.28	LT-25.79	TERRACE INLET TYPE 1	932.32	921.00	11.32	SEE SPEC. NOTES 1 AND 3
* S-208	42+45.64	LT-25.79	TERRACE INLET TYPE 1	932.30	921.00	11.30	SEE SPEC. NOTES 1 AND 3
* S-209	42+50.00	LT-25.79	TERRACE INLET TYPE 1	932.28	921.00	11.28	SEE SPEC. NOTES 1 AND 3
* S-210	42+41.28	RT-25.79	TERRACE INLET TYPE 1	932.32	923.42	8.90	SEE SPEC. NOTES 1 AND 3
* S-211	42+46.06	RT-25.79	TERRACE INLET TYPE 1	932.30	923.42	8.88	SEE SPEC. NOTES 1 AND 3
* S-212	42+50.85	RT-25.79	TERRACE INLET TYPE 1	932.28	923.42	8.86	SEE SPEC. NOTES 1 AND 3

PROPOSED STORM PIPES

PIPE	FROM	TO	DISCH.	INLET	PLAN (PAY)	PIPE	SLOPE	PIPE	TYPE	NOTES
P-1A	S-1A	S-1B	887.00	887.61	130	130	0.47%	6'X4'	CBC	
P-1B	S-1B	S-1	887.61	887.67	13	13	0.47%	6'X4'	CBC	
P-1	S-1	S-2	887.67	889.60	413	408	0.47%	6'X4'	CBC	
P-2	S-2	S-2B	889.60	889.71	27	21	0.53%	48"X76"	HERCP	
P-2A	S-2B	S-2A	893.00	899.59	121	118	5.57%	48"	RCP	
* P-2B	S-2A	S-13	899.59	912.83	297	294	4.50%	48"	RCP	
* P-3	S-3	S-4	916.50	919.87	118	112	3.02%	48"	RCP	
* P-4	S-209	S-5	926.27	926.65	45	43	0.87%	48"	RCP	
P-5	S-2	S-6	895.42	895.50	23	14	0.56%	36"	RCP	
P-6	S-6	S-7	896.45	896.56	24	22	0.50%	30"	RCP	
P-7	S-7	S-8	897.06	897.08	4	2	1.00%	24"	RCP	
P-8	S-8	S-9	897.08	897.19	24	22	0.51%	24"	RCP	
P-9	S-2B	S-15	897.00	898.00	52	49	2.03%	29"X45"	HERCP	
* P-10	S-3	S-3A	925.00	926.67	49	44	3.83%	21"	RCP	
P-11	S-11	S-12	899.5	899.8	100	100	0.30%	12"	RCP	
* P-12	S-13	S-3	912.83	916.50	116	113	3.24%	48"	RCP	
* P-13	S-13	S-14	919.00	920.33	40	39	3.45%	21"	RCP	
P-14	S-15	S-16	898.17	899.26	60	55	1.98%	27"	RCP	
P-15	S-16	S-17	899.51	904.93	120	116	4.67%	24"	RCP	
P-16	S-17	S-18	905.18	911.00	120	117	4.99%	21"	RCP	
P-17	S-15	S-10	898.42	898.90	18	16	3.05%	24"X38"	HERCP	
* P-200	S-200	S-201	900.00	901.42	43	43	3.32%	36"	TYPE II STORM BY OTHERS	
* P-201	S-201	S-202	901.42	902.67	38	38	3.31%	36"	TYPE II STORM BY OTHERS	
* P-202	S-202	S-202A	902.67	920.28	529	529	3.33%	36"	TYPE II STORM BY OTHERS	
* P-202A	S-202A	S-203	920.28	920.36	2	2	3.30%	36"	TYPE II STORM	
* P-203	S-203	S-204	920.36	920.52	5	5	3.30%	36"	TYPE II STORM	
* P-204	S-204	S-205	920.52	921.72	36	36	3.32%	36"	TYPE II STORM	
* P-205	S-205	S-206	921.72	921.88	5	5	3.28%	36"	TYPE II STORM	
* P-206	S-206	S-207	921.88	922.00	5	3	3.86%	36"	TYPE II STORM	
* P-207	S-207	S-208	921.00	921.00	5	1	0.00%	48"	RCP	
* P-208	S-208	S-209	921.00	921.00	4.60	1.37	0.00%	48"	RCP	
* P-209	S-4	S-207	919.87	921.00	42	37	3.05%	48"	RCP	
* P-210	S-207	S-210	922.00	923.42	52	47	3.00%	36"	RCP	
* P-211	S-210	S-211	923.42	923.42	5	1	0.00%	36"	RCP	
* P-212	S-211	S-212	923.42	923.42	5	1	0.00%	36"	RCP	

NOTE: PLAN LENGTH (PAY LENGTH) IS FROM CENTER OF STRUCTURE TO CENTER OF STRUCTURE. PIPE LENGTH IS ACTUAL LENGTH OF PIPE FROM STRUCTURE WALL TO STRUCTURE WALL. SLOPE CALCULATED USING PIPE LENGTH.

REMOVE SEWER STRUCTURES

STRUC. NO.	ID NO.	STATION	LOCATION (OFFSET)	TYPE	PAID (Y/N)
R-1	AE 7027-023	42+92.27	LT-16.39	48" AE W/ GATE	N

SPECIFIC NOTES

- * (1) CASTING GRADE FOR TERRACE INLET TYPES I, II AND III 0.2' BELOW TOP OF CURB GRADE. SEE CITY OF MADISON SDD5.7.12, 5.7.12A AND 5.7.12I
- (2) SEE SHEET S-5 FOR DETAILS. STRUCTURE TO BE BUILT WITH 1' OF VERTICAL ADJUSTMENT TO ACCOUNT FOR GRADING.
- * (3) S-207, S-208 AND S-209 AND S-210, S-211 AND S-212 TO BE BUILT IN SET OF THREE WITH ONE CURB CUT ON EITHER SIDE OF EACH BLOCK

STANDARD NOTES:

- PLAN LENGTH (PAY LENGTH) IS FROM CENTER OF STRUCTURE TO CENTER OF STRUCTURE. PIPE LENGTH IS ACTUAL LENGTH OF PIPE FROM STRUCTURE WALL TO STRUCTURE WALL. SLOPE CALCULATED USING PIPE LENGTH.
- KOR N SEAL BOOTS OR EQUIVALENT SHALL BE USED FOR ALL PIPE CONNECTIONS TO INLETS. IN ADDITION, KOR N SEAL BOOTS SHALL BE REQUIRED FOR ANY TYPE II PIPE CONNECTIONS TO SAS STORM STRUCTURES. CONCRETE COLLARS OR KOR N SEAL MAY BE USED FOR ANY RCP OR HERCP CONNECTIONS TO SAS STORM STRUCTURES.
- ALL REBAR FOR FIELD POURED STRUCTURES SHALL BE EPOXY COATED. ANY EXPOSED STEEL SHALL BE TOUCHED UP OR RECOATED PRIOR TO USE.
- ALL FIELD POURED SAS STORM STRUCTURES SHALL BE CONSTRUCTED IN ACCORDANCE WITH STANDARD DETAIL DRAWING 5.7.3. ALL PRECAST SAS STORM STRUCTURES SHALL BE CONSTRUCTED IN ACCORDANCE WITH STANDARD DETAIL DRAWING 5.7.5.

- ABBREVIATIONS: AE = APRON ENDWALL; RCP = REINFORCED CONCRETE PIPE; HERCP = HORIZONTAL ELLIPTICAL REINFORCED CONCRETE PIPE; DNA = DOES NOT APPLY; SAS = SEWER ACCESS STRUCTURE; LP = LOW POINT INLET STRUCTURE; FP = FIELD POURED STRUCTURE; TR = TOP OF CONCRETE ROOF; NCM = NO CROWN MATCH FOR PIPES; UD = UNDERDRAIN
- APPROXIMATE DISCHARGE E.I. GIVEN, ADJUST E.I. AND PIPE SLOPE IN THE FIELD.
- TOP OF CASTING GRADE GIVEN IS THE TOP OF CURB FOR INLET STRUCTURES AND THE FLOWLINE OF THE CLOSED CASTING FOR SAS's.
- ALL REINFORCED CONCRETE PIPES TO BE CLASS III UNLESS OTHERWISE NOTED.
- SURVEYOR TO CONFIRM THAT ALL INLET STATION / OFFSETS LINE UP WITH PROPOSED CURB AND GUTTER.
- ALL STRUCTURES CALLED OUT AS FIELD POURED SHALL BE FIELD POURED. ALL OTHER STRUCTURES (NOT INDICATED AS FIELD POURED) SHALL BE SUBMITTED TO CITY ENGINEERING FOR APPROVAL IF PRECAST STRUCTURES ARE PREFERRED. CONTACT LAUREN STRIEGL OF CITY ENGINEERING AT (608) 266-4094 FOR PRECAST APPROVALS, FAX SHOP DRAWINGS TO (608)264-9275, OR EMAIL SHOP DRAWINGS TO LSTRIEGL@CITYOFMADISON.COM.

SANITARY SEWER SCHEDULE

*REV 10/7/20 LES

CITY VIEW DRIVE ASSESSMENT DIST - 2020	SHEET NO.
PROJECT NO. 11958	U-9
SANITARY SEWER SCHEDULE	
CITY OF MADISON	

PROPOSED SANITARY STRUCTURES

SAS NO.	STATION	LOCATION (OFFSET)	TOP OF CASTING	E.I.	DEPTH (FT)	NOTES
* SAS#1	37+00.00	CL	907.91	898.00	9.91	[1] [2]

PROPOSED SANITARY PIPES

FROM (DNSTM)	TO (UPSTM)	DWNSTRM E.I.	UPSTRM E.I.	PLAN LGTH (FT)	SLOPE (%)	PIPE SIZE	PVC TYPE	NOTES
* EX SAS 7028-002	SAS#1	895.37	898.00	159	1.65%	8"	SDR-35	

SANITARY STRUCTURE REMOVALS

SAS NO.	STATION	LOCATION (OFFSET)	TOP OF CASTING	E.I.	DEPTH (FT)	NOTES
* EX SAS 7028-003	37+00.00	CL	908.40	899.78	8.62	-

SANITARY PIPE REMOVALS

FROM (DNSTM)	TO (UPSTM)	PLAN LGTH (FT)	PAID (Y/N)	PLAN (PAY) LGTH (FT)	PIPE SIZE	PIPE TYPE	NOTES
* EX SAS 7028-002	EX SAS 7028-003	159	N	0	8"	PVC	

NOTES:

- [1] INSTALL INTERNAL CHIMNEY SEAL IN ACCORDANCE WITH S.D.D. 5.7.17
- [2] INSTALL EXTERNAL SEWER ACCESS STRUCTURE JOINT SEAL IN ACCORDANCE WITH S.D.D. 5.7.2

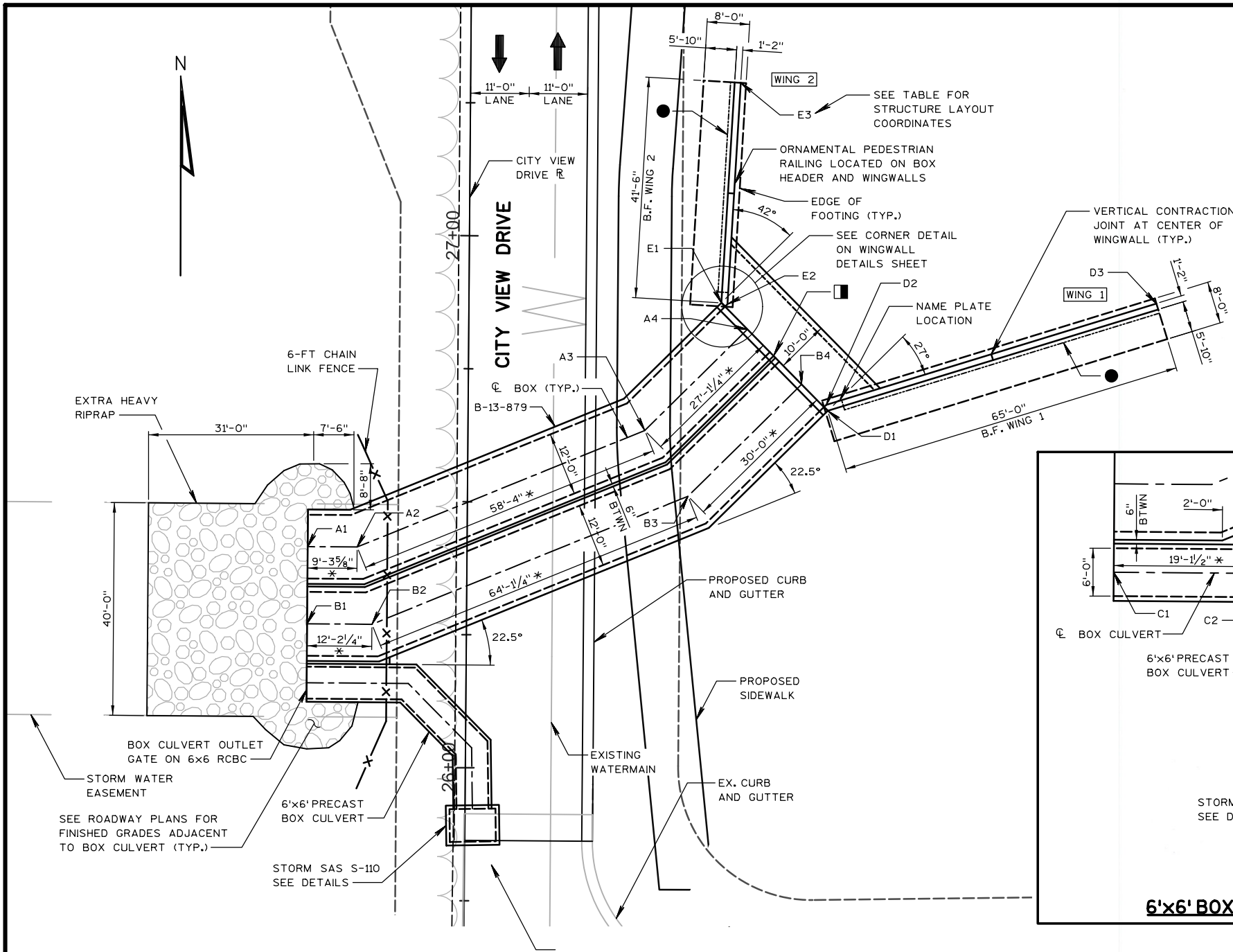

- LEGEND**
- PROVIDE A VERTICAL EXPANSION JOINT IN BOX INLET HEADER. LOCATE DIRECTLY OVER GAP BETWEEN ADJACENT 12'x6' BOXES. USE 3/4" JOINT FILLER AND FILL WITH NON-STAINING GRAY NON-BITUMINOUS JOINT SEALER. DO NOT RUN BAR STEEL THROUGH JOINT.
 - BOX CULVERT LAYOUT DIMENSIONS PROVIDED ALONG CENTERLINE OF BOX CULVERT CELL.
 - PIPE UNDERDRAIN WRAPPED BEHIND WALL. SLOPE 0.5% MIN. AND DISCHARGE THROUGH WALL NEAR BOX CULVERT.

- GENERAL NOTES**
- DRAWINGS SHALL NOT BE SCALED.
- ALL STATIONS AND ELEVATIONS ARE IN FEET.
- FOR CAST-IN-PLACE CONCRETE, ALL BAR STEEL REINFORCEMENT SHALL BE EMBEDDED 2" CLEAR UNLESS OTHERWISE SHOWN OR NOTED.
- BEVEL EXPOSED EDGES OF CAST-IN-PLACE CONCRETE 3/4" UNLESS OTHERWISE SHOWN OR NOTED.
- WITHIN THE LENGTH OF CULVERT ALL SPACES EXCAVATED AND NOT OCCUPIED BY THE NEW STRUCTURE SHALL BE BACKFILLED WITH SELECT FILL.
- THE CLEAR SPACING BETWEEN BARRELS SHALL BE 6 INCHES AND THE SPACE BETWEEN ADJACENT BARRELS FROM TOP OF BEDDING TO TOP OF TOP SLAB SHALL BE FILLED WITH GRADE "B" CONCRETE. CONCRETE FILL TO BE INCLUDED WITH RCBC BID ITEM.
- PRECAST BOXES SHALL BE TIED TOGETHER USING GALVANIZED STEEL JOINT TIES. SEE BOX CULVERT DETAILS. JOINT TIES TO BE INCLUDED WITH RCBC BID ITEM.

- DESIGN DATA**
- LIVE LOAD: _____
DESIGN LOADING _____ HL-93
- EARTH LOAD:
DESIGN FOR FILL HEIGHT OF LESS THAN 2 FEET.
- MATERIAL PROPERTIES:
 PRECAST CONCRETE _____ f'c = 5,000 PSI
 CAST-IN-PLACE CONCRETE _____ f'c = 3,500 PSI
 BAR STEEL REINFORCEMENT (CAST IN PLACE) _____ fy = 60,000 PSI
 STEEL REINFORCEMENT (FOR PRECAST) _____ REFER TO ASTM C1577
- BOX CULVERT AND WING WALLS HAVE BEEN DESIGNED FOR A FACTORED BEARING RESISTANCE OF 3,500 PSF BASED ON GEOTECHNICAL RECOMMENDATIONS PREPARED BY CGC, INC., DATED 2/27/2020.

STRUCTURE DESIGN CONTACT
BRETT OFTEDAHL (608) 251-4843

STRUCTURE LAYOUT COORDINATES

POINT	X	Y	DESCRIPTION
A1	847,323.06	501,149.92	C/L AT OUTLET
A2	847,332.36	501,149.86	BEND
A3	847,386.40	501,171.85	BEND
A4	847,405.68	501,190.90	C/L AT INLET
B1	847,322.97	501,135.42	C/L AT OUTLET
B2	847,335.16	501,135.34	BEND
B3	847,394.53	501,159.51	BEND
B4	847,415.87	501,180.58	C/L AT INLET
C1	847,322.90	501,124.34	C/L AT OUTLET
C2	847,342.02	501,124.22	BEND
C3	847,353.94	501,112.15	BEND
C4	847,354.11	501,100.68	C/L AT INLET
D1	847,420.79	501,175.60	END OF BOX/BACK OF WING 1
D2	847,420.52	501,176.74	F.F. END OF WING 1
D3	847,482.56	501,195.88	F.F. END OF WING 1
E1	847,400.76	501,195.88	END OF BOX/BACK OF WING 2
E2	847,401.92	501,195.61	F.F. END OF WING 2
E3	847,404.36	501,237.24	F.F. END OF WING 2

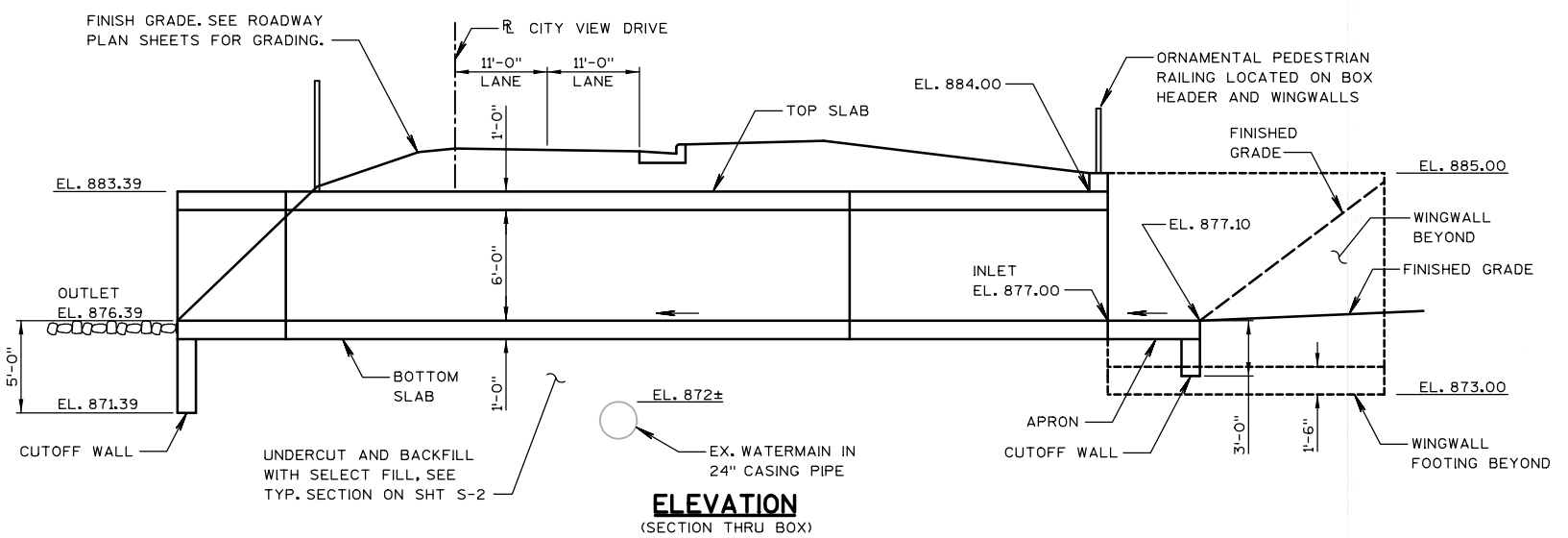
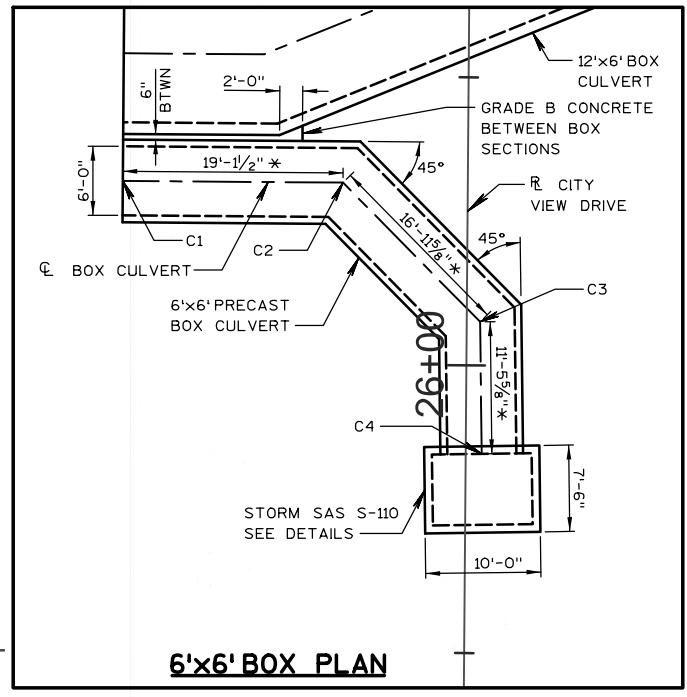

- LIST OF DRAWINGS**
- S-1 GENERAL PLAN AND NOTES
 - S-2 BOX CULVERT DETAILS-1
 - S-3 BOX CULVERT DETAILS-2
 - S-4 WINGWALL DETAILS
 - S-5 STORM SEWER ACCESS STRUCTURE S-2
 - S-6 STORM SEWER ACCESS STRUCTURE S-110

B-13-879
GENERAL PLAN AND NOTES
CITY VIEW DRIVE BOX CULVERT
CITY OF MADISON
MADISON, WISCONSIN

NO.	REVISIONS	DATE

JOB NO. 1020.115
PROJECT MGR. BMO

STRAND ASSOCIATES

SHEET S-1

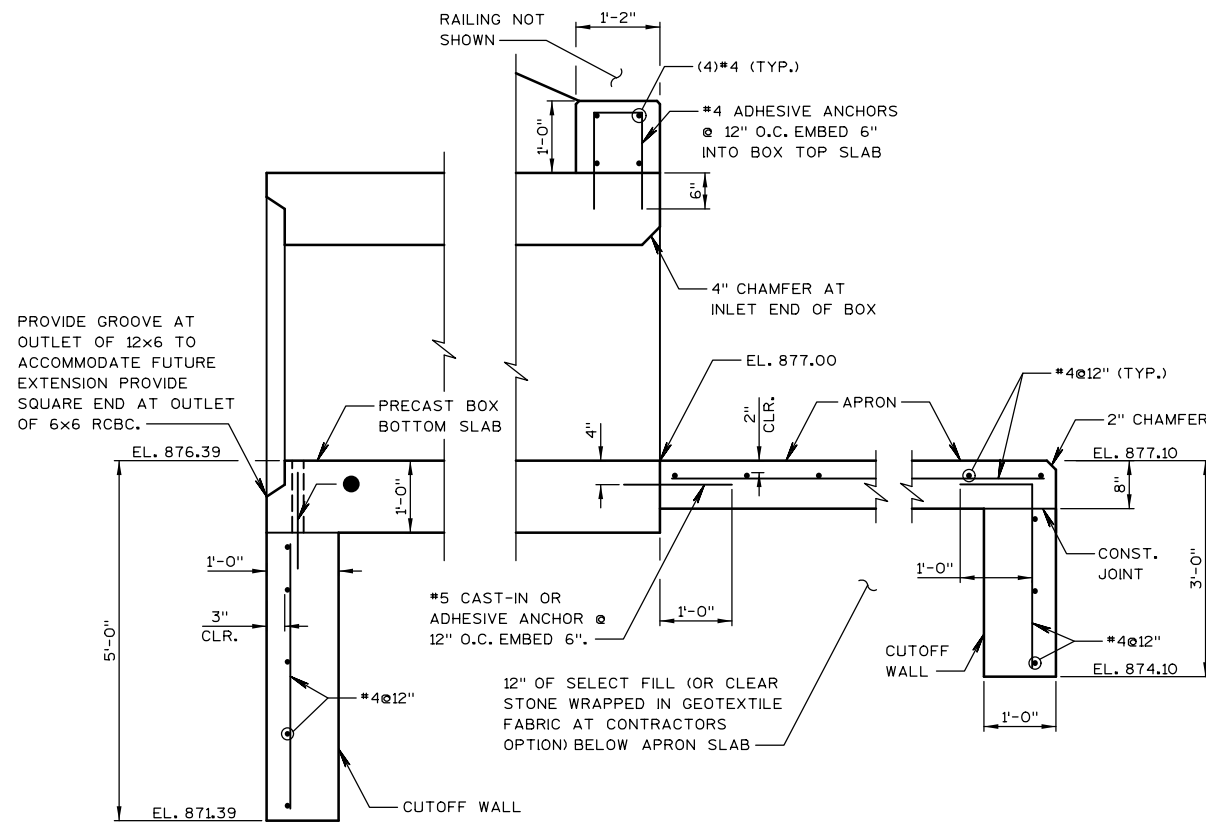

CROSS SECTION AT OUTLET

CROSS SECTION AT INLET

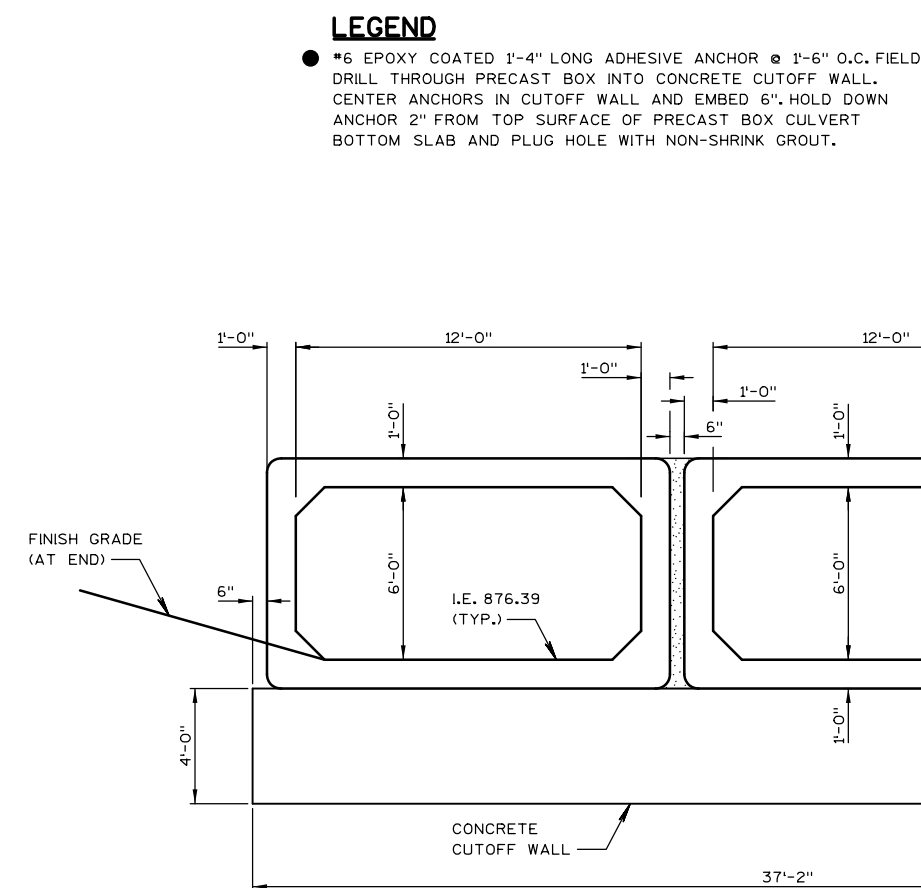

SECTION THRU BOX CULVERT AT OUTLET
(LOOKING EAST)

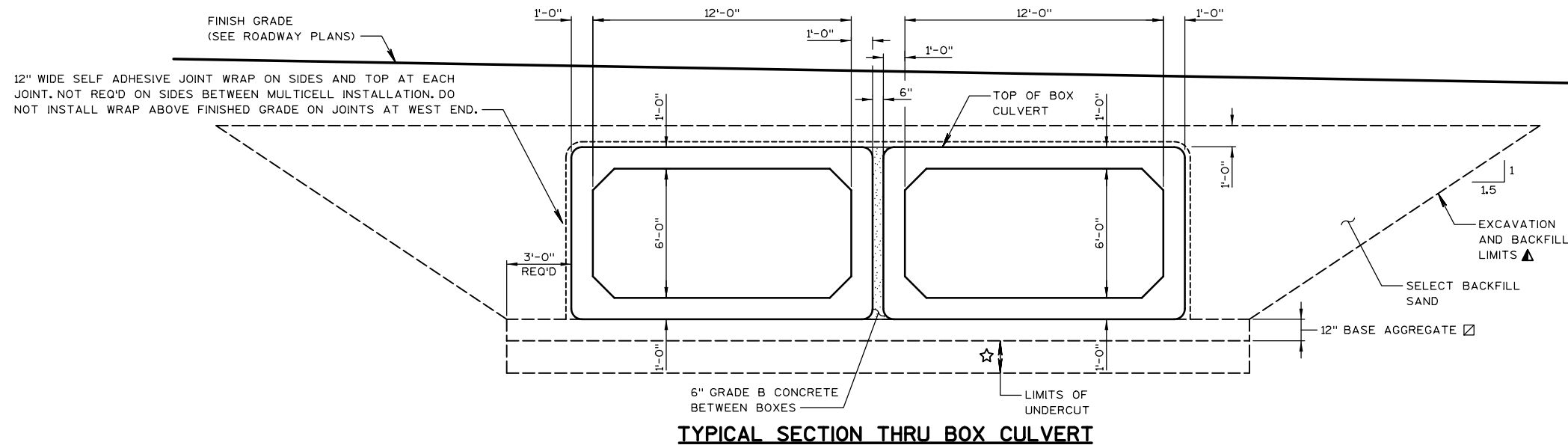

TYPICAL SECTION THRU BOX CULVERT

- ▲ EXCAVATION AND BACKFILL INCLUDED IN PRECAST REINFORCED CONCRETE BOX CULVERT BID ITEM.
- ☆ UNDERCUT TO REMOVE EXISTING FILL AND ORGANIC SOILS TO EXPOSE DENSE NATURAL SAND SOILS AT AN ESTIMATED ELEVATION OF 871.00. BACKFILL WITH SELECT FILL SAND. GRANULAR SOILS EXPOSED AT FOOTING GRADE OR BOTTOM OF UNDERCUT SHOULD BE THOROUGHLY RECOMPACTED PRIOR TO BACKFILLING OR FORMWORK/CONCRETE PLACEMENT. USE CAUTION WHEN EXCAVATING UNDERCUT NEAR WATERMAIN.
- ☒ 12" BASE AGGREGATE BELOW BOX CULVERT SHALL BE INCLUDED IN PRECAST REINFORCED CONCRETE BOX CULVERT BID ITEM. ALL REQUIRED UNDERCUT AND BACKFILL BELOW THE BASE AGGREGATE WILL BE MEASURED FOR PAYMENT. BASE AGGREGATE SHALL BE SELECT FILL SAND OR CLEAR STONE WRAPPED IN GEOTEXTILE FABRIC AT CONTRACTOR'S OPTION.

NOTE: SOIL CONDITIONS MAY DIFFER AT THE ACTUAL CULVERT LOCATION WHEN COMPARED WITH THE SOIL BORING LOCATION. SUBGRADES SHOULD BE CHECKED BY THE PROJECT GEOTECHNICAL ENGINEER TO DOCUMENT THAT THE SUBGRADE SOILS ARE SUITABLE FOR FOOTING SUPPORT OR OTHERWISE ADVISE ON CORRECTIVE MEASURES.

LEGEND

- *6 EPOXY COATED 1'-4" LONG ADHESIVE ANCHOR @ 1'-6" O.C. FIELD DRILL THROUGH PRECAST BOX INTO CONCRETE CUTOFF WALL. CENTER ANCHORS IN CUTOFF WALL AND EMBED 6". HOLD DOWN ANCHOR 2" FROM TOP SURFACE OF PRECAST BOX CULVERT BOTTOM SLAB AND PLUG HOLE WITH NON-SHRINK GROUT.

NOTES

CAST-IN-PLACE ELEMENTS MAY BE PRECAST AT THE OPTION OF THE CONTRACTOR. DETAILS MUST BE SHOWN ON THE SHOW DRAWINGS FOR APPROVAL.

PRECAST CUT OFF WALLS MAY BE FIELD SPLICED SUBJECT TO ENGINEER REVIEW AND APPROVAL OF PROPOSED SPLICE DETAIL.

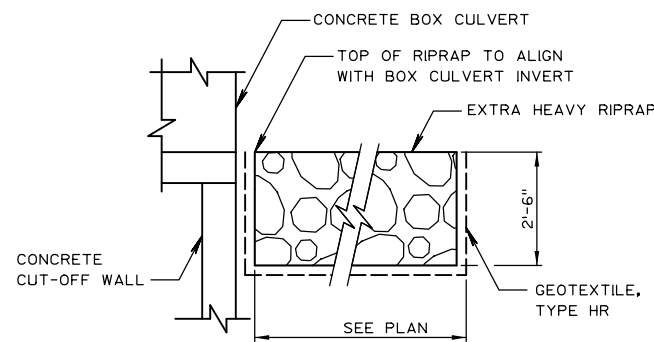

RIPRAP AT OUTFALL

NO.	REVISIONS	DATE

B-13-879
BOX CULVERT DETAILS - 1
CITY VIEW DRIVE BOX CULVERT
CITY OF MADISON
MADISON, WISCONSIN

JOB NO.
1020.115
PROJECT MGR.
BMO



SHEET
S-2

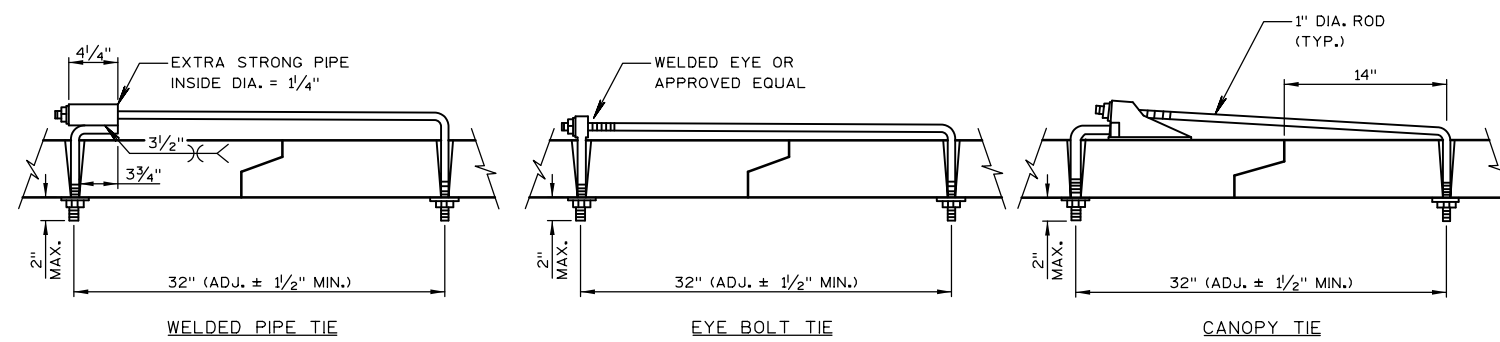

JOINT TIES

NOTES:
EITHER EYE BOLT TIES, WELDED PIPE TIES, OR CANOPY TIES MAY BE USED. THREADS MAY BE CUT OR ROLLED. TIE NUTS SHALL BE TIGHTENED TO MEET PRECAST MANUFACTURER'S RECOMMENDATIONS. (2 TIES REQ'D. PER JOINT.) (TIES TO BE GALVANIZED STEEL.)

JOINT TIES SHALL BE INCLUDED WITH PRECAST REINFORCED BOX CULVERT BID ITEMS.

NOTES

DETAILS FOR MATERIALS, FABRICATION, CONSTRUCTION AND DESIGN OF PRECAST BOX CULVERTS NOT SHOWN OR STATED ON THIS DRAWING SHALL BE IN ACCORDANCE WITH THE CURRENT ASTM SPECIFICATION, C1577; AASHTO LRFD BRIDGE DESIGN SPECIFICATIONS; WISCONSIN DOT BRIDGE MANUAL; WISCONSIN DOT STANDARD SPECIFICATIONS & APPLICABLE SPECIAL PROVISIONS, EXCEPT THAT THE CONCRETE MIXTURE SHALL CONTAIN NOT LESS THAN 565 LBS. OF CEMENTITIOUS MATERIALS PER CUBIC YARD.

THE DESIGN OF PRECAST BOX CULVERTS WITH ALL FILL HEIGHTS SHALL BE AS STATED IN ASTM C1577.

NOT MORE THAN FOUR (4) HOLES MAY BE CAST, DRILLED OR OTHERWISE NEATLY MADE IN THE SHELL OF EACH PIECE OF BOX SECTION FOR HANDLING. THE HOLES SHALL BE TAPERED UNLESS DRILLED. HOLES SHALL BE FILLED WITH PORTLAND CEMENT MORTAR EXCEPT TAPERED HOLES MAY BE FILLED WITH CONCRETE PLUGS SECURED WITH PORTLAND CEMENT MORTAR OR OTHER APPROVED ADHESIVE.

SEAL JOINTS IN ACCORDANCE WITH ARTICLE 505.3.4 OF THE CITY OF MADISON STANDARD SPECS AND THE RBC SPECIAL PROVISIONS. PROVIDE 12" WIDE BUTYL RUBBER JOINT WRAP OVER SIDES AND TOP OF CULVERT JOINTS. JOINT WRAP NOT REQUIRED OVER WALL JOINTS BETWEEN MULTICELL INSTALLATIONS WHERE CONCRETE FILL WILL BE PLACED.

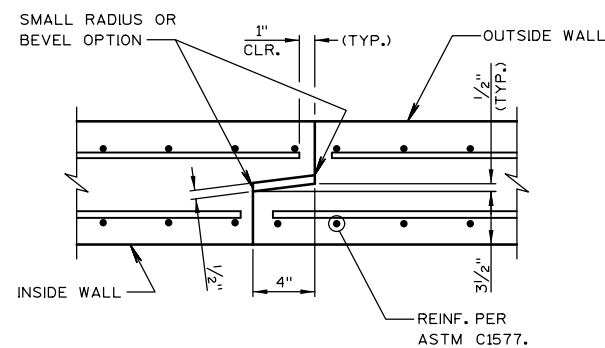

JOINT DETAIL

NOTE:
THIS JOINT DETAIL IS BASED ON WISDOT STANDARDS. PRECASTER MAY PROPOSED ALT. JOINT DETAIL TO ENGINEER FOR REVIEW.

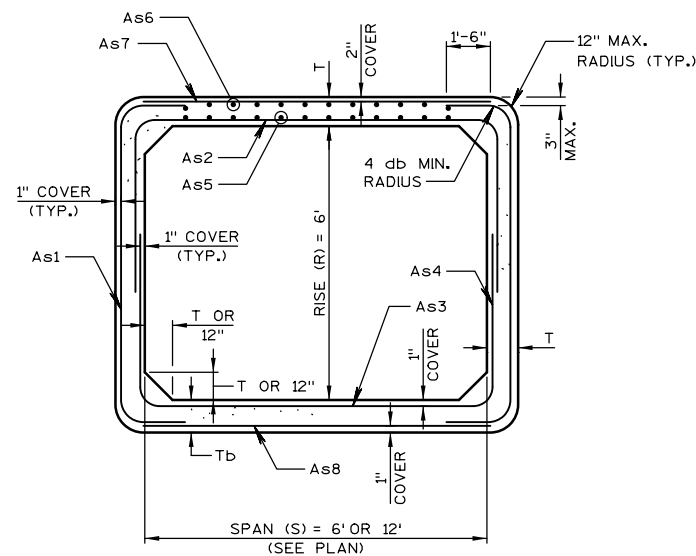

SECTION THRU BARREL

NOTE:
TYPICAL SECTION SHOWN IS FOR LESS THAN 2 FEET OF COVER. FOLLOW ASTM C1577 FOR TYPICAL REINF. FOR BOX CULVERT WITH DESIGN EARTH COVER OF MORE THAN 2 FEET.

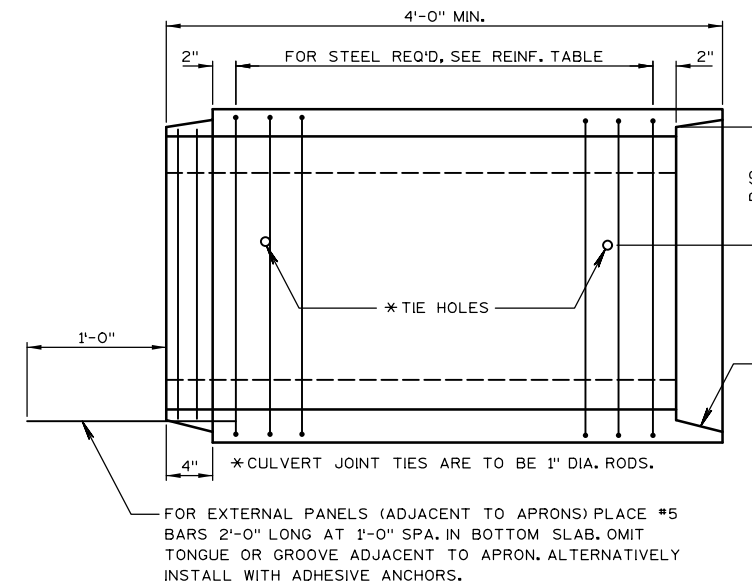

LONGITUDINAL SECTION

BOX CULVERT DESIGN CRITERIA:

DESIGN AND CONSTRUCT PRECAST BOX CULVERT IN ACCORDANCE WITH ASTM C1577. DESIGN EARTH COVER SHALL BE AS STATED IN SPECIAL PROVISIONS. MINIMUM CIRCUMFERENTIAL REINFORCEMENT AREAS (SQ. INCHES) ARE PROVIDED BELOW BASED ON ASTM C1577.

	As1	As2	As3	As4	As5	As6	As7	As8	M	T
6x4	0.18	0.27	0.27	0.17	--	--	--	--	38 IN.	7 IN
6x6	0.19	0.38	0.30	0.17	0.19	0.19	0.19	0.19	--	7 IN*
12x6	0.32	0.36	0.32	0.29	0.29	0.29	0.29	0.29	--	12 IN

* TOP SLAB = 8 IN.

NO.	REVISIONS	DATE:

B-13-879
BOX CULVERT DETAILS - 2
CITY VIEW DRIVE BOX CULVERT
CITY OF MADISON
MADISON, WISCONSIN

JOB NO.
1020.115
PROJECT MGR.
BMO



SHEET
S-3

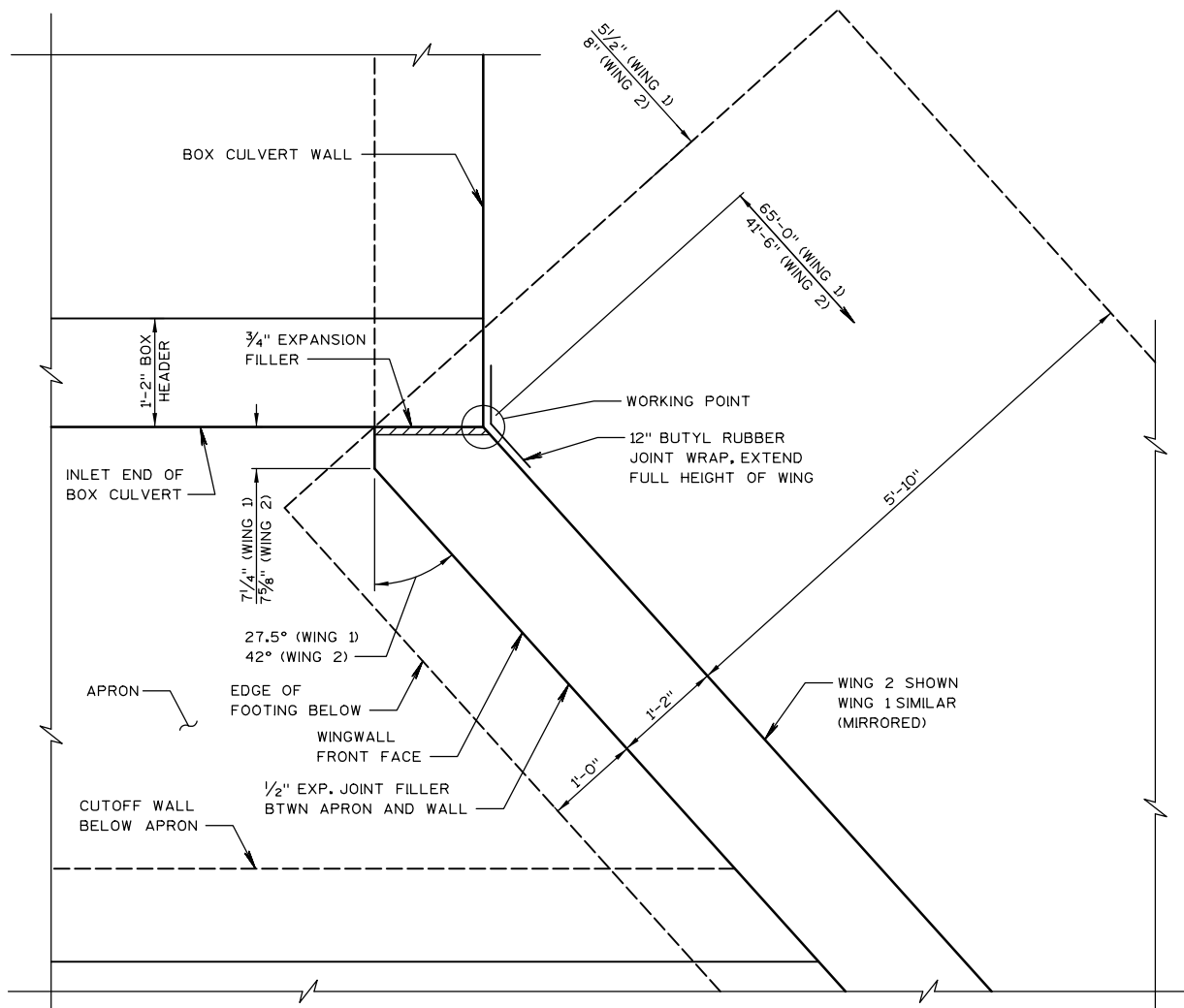

WING 2 CORNER PLAN
(WING 1 DETAIL SIMILAR, MIRRORED)

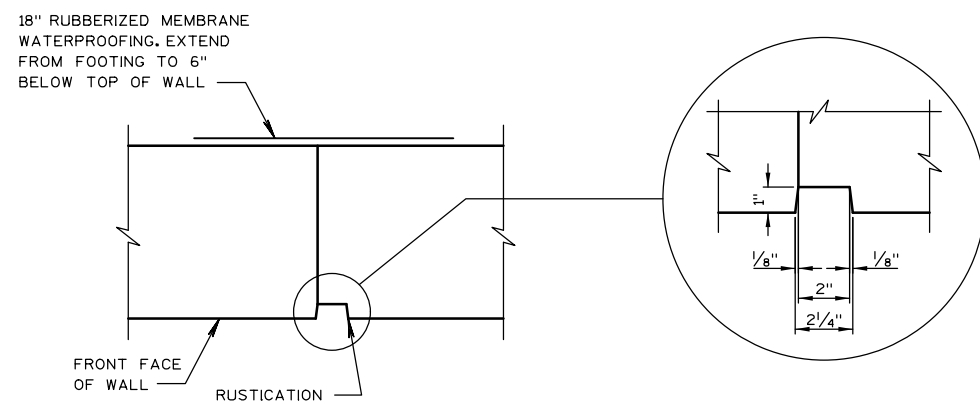

VERTICAL CONTRACTION JOINT
DO NOT RUN ANY BAR STEEL THRU JOINT

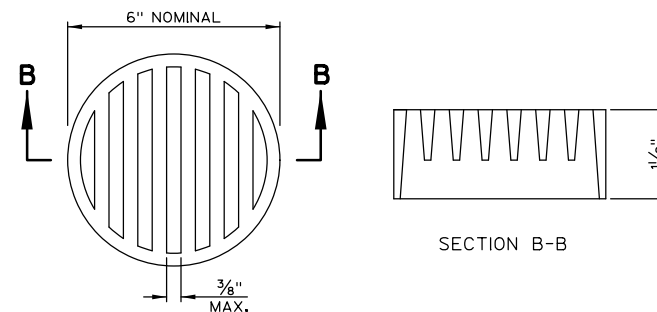

NOTES:
DIMENSIONS ARE APPROXIMATE. THE GRATE IS SIZED TO FIT INTO A PIPE COUPLING. ORIENT SHIELD SO SLOTS ARE VERTICAL.

THE RODENT SHIELD, PIPE COUPLING AND ATTACHMENT SCREWS SHALL BE INCLUDED WITH BID ITEM "PIPE UNDERDRAIN WRAPPED 6-INCH."

THE RODENT SHIELD SHALL BE A PVC GRATE SIMILAR TO THIS DETAIL. THE GRATE IS COMMERCIALY AVAILABLE AS A FLOOR STRAINER. A PIPE COUPLING IS REQUIRED FOR THE ATTACHMENT OF THIS SHIELD TO THE EXPOSED END OF THE PIPE UNDERDRAIN. THE SHIELD SHALL BE FASTENED TO THE PIPE COUPLING WITH TWO OR MORE NO. 10 x 1-INCH STAINLESS STEEL SHEET METAL SCREWS.

RODENT SHIELD DETAIL

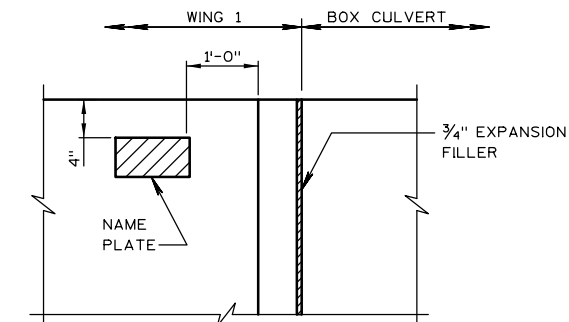

NAME PLATE

NOTES:
INSTALL STRUCTURE NAME PLATE SHOWING STRUCTURE NUMBER B-13-879 AND YEAR BUILT. NAME PLATE SHALL BE FABRICATED AND INSTALLED IN ACCORDANCE WITH WISDOT STANDARD SPECIFICATIONS SECTIONS 502.3.11 AND 506.2.4. NAME PLATE SHALL BE INCLUDED IN BID ITEM "CAST-IN-PLACE WINGWALLS AND APRON".

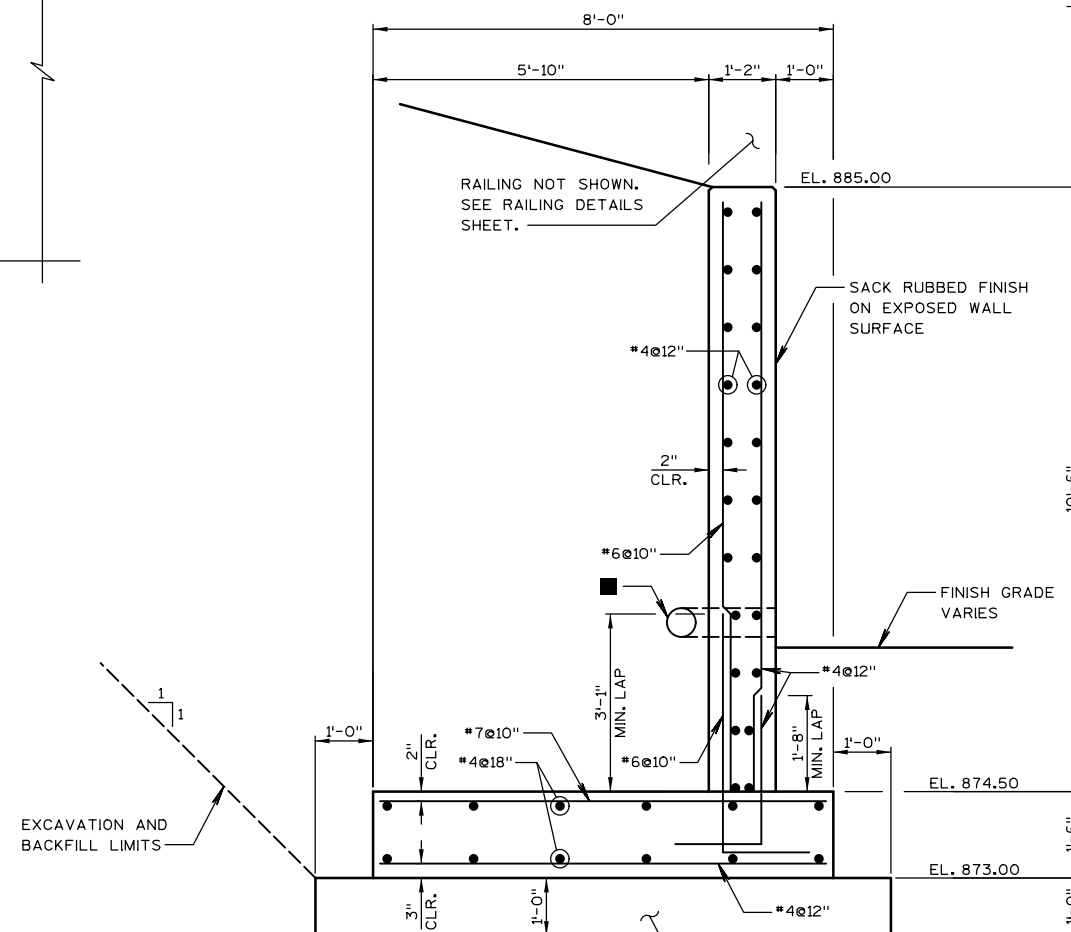

SUBGRADE TO BE REVIEWED BY PROJECT GEOTECHNICAL ENGINEER. UNDERCUT MAY BE REQUIRED TO EXPOSE DENSE SAND LAYER. SUBGRADE PREPARATION AND UNDERCUT, IF REQUIRED SHALL BE IN ACCORDANCE WITH NOTES ON SHT S-2 FOR BOX CULVERT TYPICAL SECTION.

TYPICAL SECTION THRU WINGWALL

NOTES

VERTICAL CONTRACTION JOINT LOCATIONS ARE SHOWN ON PLAN.

CONSTRUCT WINGWALLS IN ACCORDANCE WITH SECTION 502 OF THE WISDOT STANDARD SPECS. PROVIDE SACK RUBBED SURFACE FINISH ON EXPOSED SURFACES OF WALLS IN ACCORDANCE WITH SECTION 502.3.7.5.

LEGEND

- PIPE UNDERDRAIN WRAPPED 6-INCH. SLOPE 0.5% MIN. TO DISCHARGE THRU WALL. ATTACH SOLID CAP AT BURIED END AND RODENT SHIELD AT DISCHARGE. SEE RODENT SHIELD DETAIL THIS SHEET. PIPE UNDERDRAIN AND RODENT SHIELD SHALL BE INCLUDED IN BID ITEM "CAST IN PLACE WINGWALLS AND APRON".

NO.	REVISIONS	DATE

B-13-879
WINGWALL DETAILS
CITY VIEW DRIVE BOX CULVERT
CITY OF MADISON
MADISON, WISCONSIN

JOB NO.
1020.115
PROJECT MGR.
BMO



SHEET
S-4

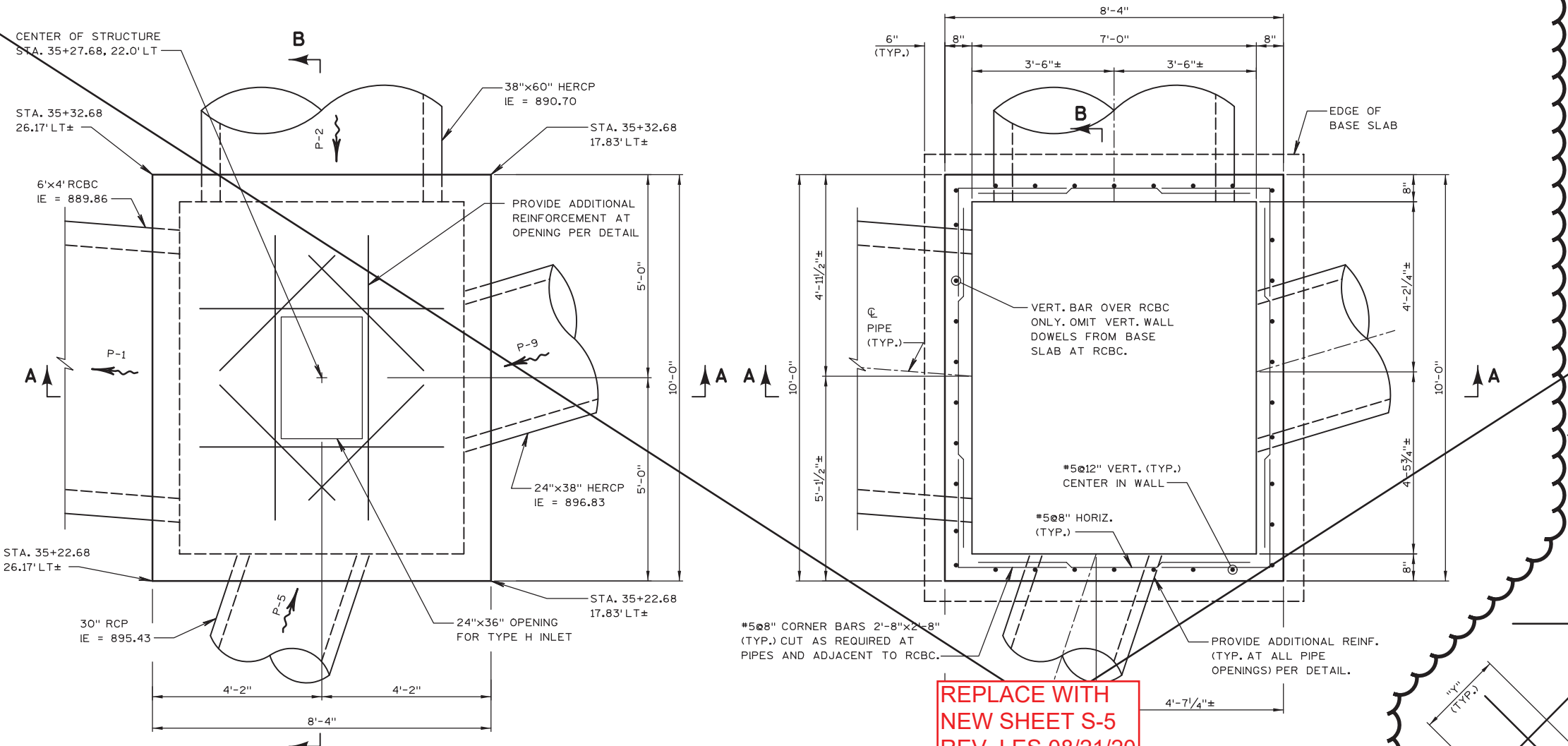

GENERAL NOTES

ALL BAR STEEL REINFORCEMENT SHALL BE EMBEDDED 2 INCHES CLEAR UNLESS OTHERWISE SHOWN OR NOTED.

ALL ITEMS SHOWN IN THIS DETAIL, EXCEPT STORM SEWER PIPES, ARE INCLUDED IN BID ITEM "STORM SAS-SPECIAL".

CONTRACTOR MAY CHOOSE TO PRECAST TOP SLAB AND LIFT SLAB ONTO STRUCTURE. IF TOP SLAB IS NOT CAST IN PLACE, USE THE ALTERNATE SLAB JOINT DETAIL SHOWN IN DETAIL "A" ON SHEET S-6.

REFER TO STORM SEWER PLANS FOR PIPE SIZES, INVERT ELEVATIONS AND STATION/OFFSET TO CENTER OF STRUCTURE.

REINFORCING STEEL SHALL MEET REQUIREMENTS OF WISDOT STANDARD SPECIFICATIONS SECTION 505.

EXCAVATION FOR STRUCTURE SHALL BE BACKFILLED WITH SELECT FILL SAND.

DESIGN DATA:
 CONCRETE MASONRY: $f'_c = 4000$ PSI
 STEEL REINFORCING: $F_y = 60$ KSI

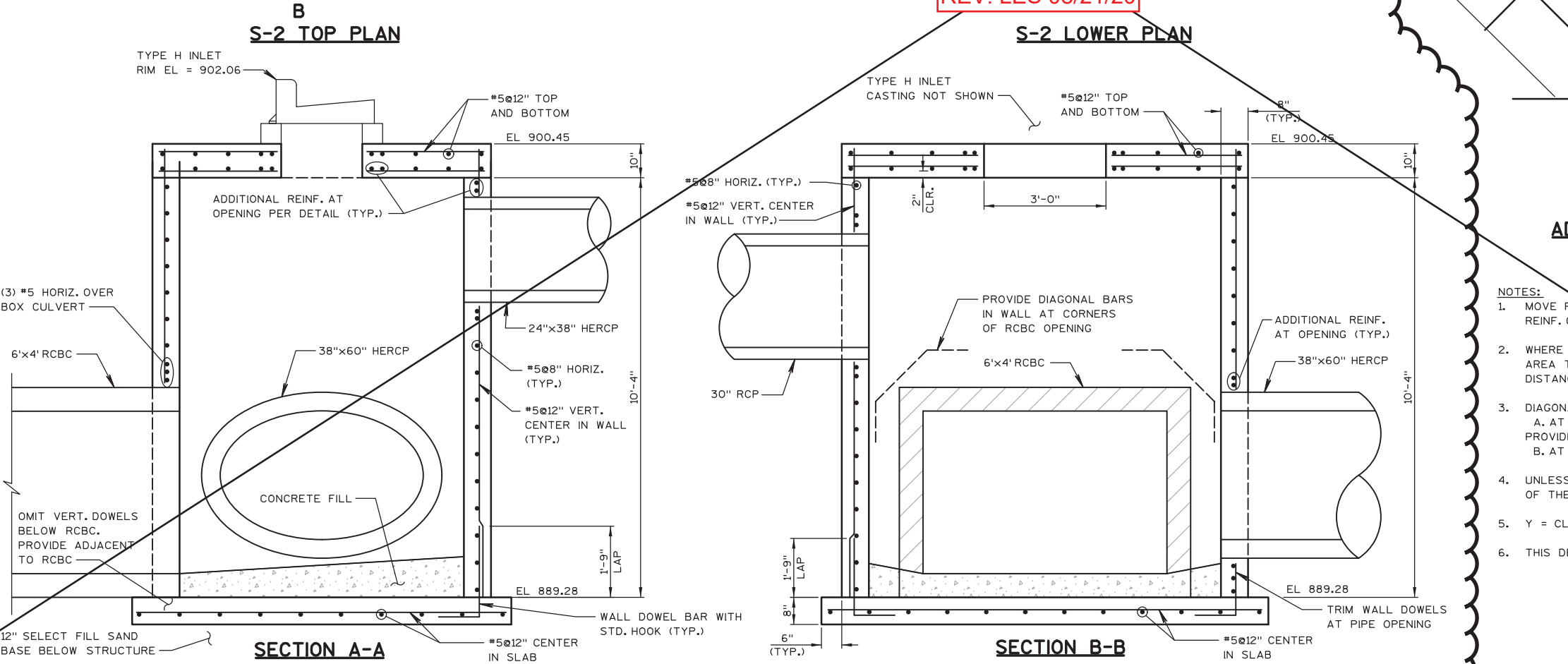
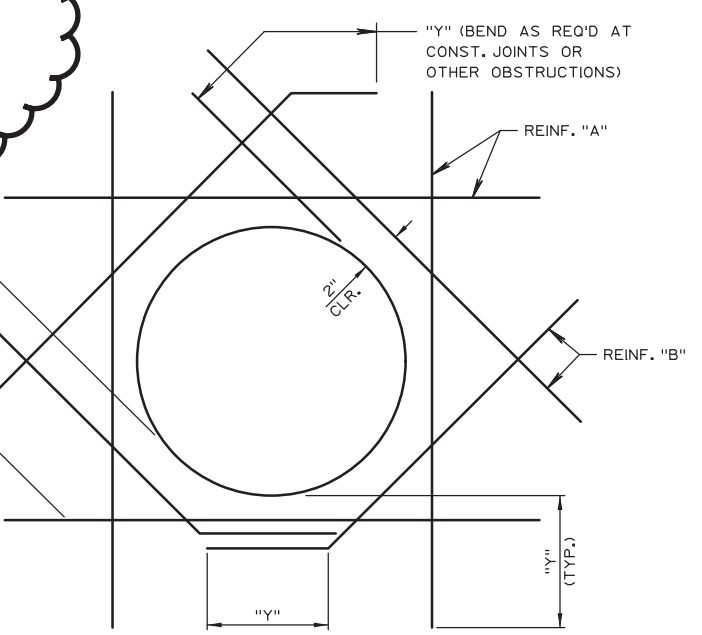

- ADDITIONAL REINFORCEMENT AT CONCRETE OPENINGS**
- NOTES:**
1. MOVE REINF. MAX. OF 2" TO CLEAR OPENING TO AVOID CUTTING REINF. CUT REMAINING BARS THAT PASS THROUGH OPENING.
 2. WHERE REINF. MUST BE CUT, ADD REINF. "A" AT LEAST EQUAL IN AREA TO THAT WHICH WAS CUT AND EXTEND BEYOND OPENING DISTANCE "Y".
 3. DIAGONAL BARS "B" TO BE PLACED:
 - A. AT EACH FACE OF WALL WHERE TWO LAYERS OF REINF. ARE PROVIDED.
 - B. AT TOP & BOTTOM OF ALL SLABS.
 4. UNLESS OTHERWISE NOTED, SIZE OF REINF. "B" SHALL BE THE SIZE OF THE LARGEST REINF. BAR CUT.
 5. Y = CLASS B LAP (#5 BAR = 1'-10")
 6. THIS DETAIL IS TO BE USED WHEN NO OTHER DETAIL IS SPECIFIED.

NO.	REVISIONS	DATE
1	REVISED ALL DIMENSIONS	6/10/20

STORM SAS-SPECIAL
S-2 PLAN AND DETAILS
 CITY VIEW DRIVE BOX CULVERT
 CITY OF MADISON
 MADISON, WISCONSIN

JOB NO.
1020.115
PROJECT MGR.
BMO



SHEET
S-5

STRUCTURAL DETAIL (NOT TO SCALE)

CITY VIEW DRIVE CITY OF MADISON

REV. LES 08/28/20

GENERAL NOTES

ALL BAR STEEL REINFORCEMENT SHALL BE EMBEDDED 2 INCHES CLEAR UNLESS OTHERWISE SHOWN OR NOTED.

ALL ITEMS SHOWN IN THIS DETAIL, EXCEPT STORM SEWER PIPES, ARE INCLUDED IN BID ITEM "STORM SAS-SPECIAL".

CONTRACTOR MAY CHOOSE TO PRECAST TOP SLAB AND LIFT SLAB ONTO STRUCTURE. IF TOP SLAB IS NOT CAST IN PLACE, USE THE ALTERNATE SLAB JOINT DETAIL SHOWN IN DETAIL "A" ON SHEET S-6.

REFER TO STORM SEWER PLANS FOR PIPE SIZES, INVERT ELEVATIONS AND STATION/OFFSET TO CENTER OF STRUCTURE.

REINFORCING STEEL SHALL MEET REQUIREMENTS OF WISDOT STANDARD SPECIFICATIONS SECTION 505.

EXCAVATION FOR STRUCTURE SHALL BE BACKFILLED WITH SELECT FILL SAND.

DESIGN DATA:

CONCRETE MASONRY: $f'_c = 4000$ PSI
STEEL REINFORCING: $F_y = 60$ KSI

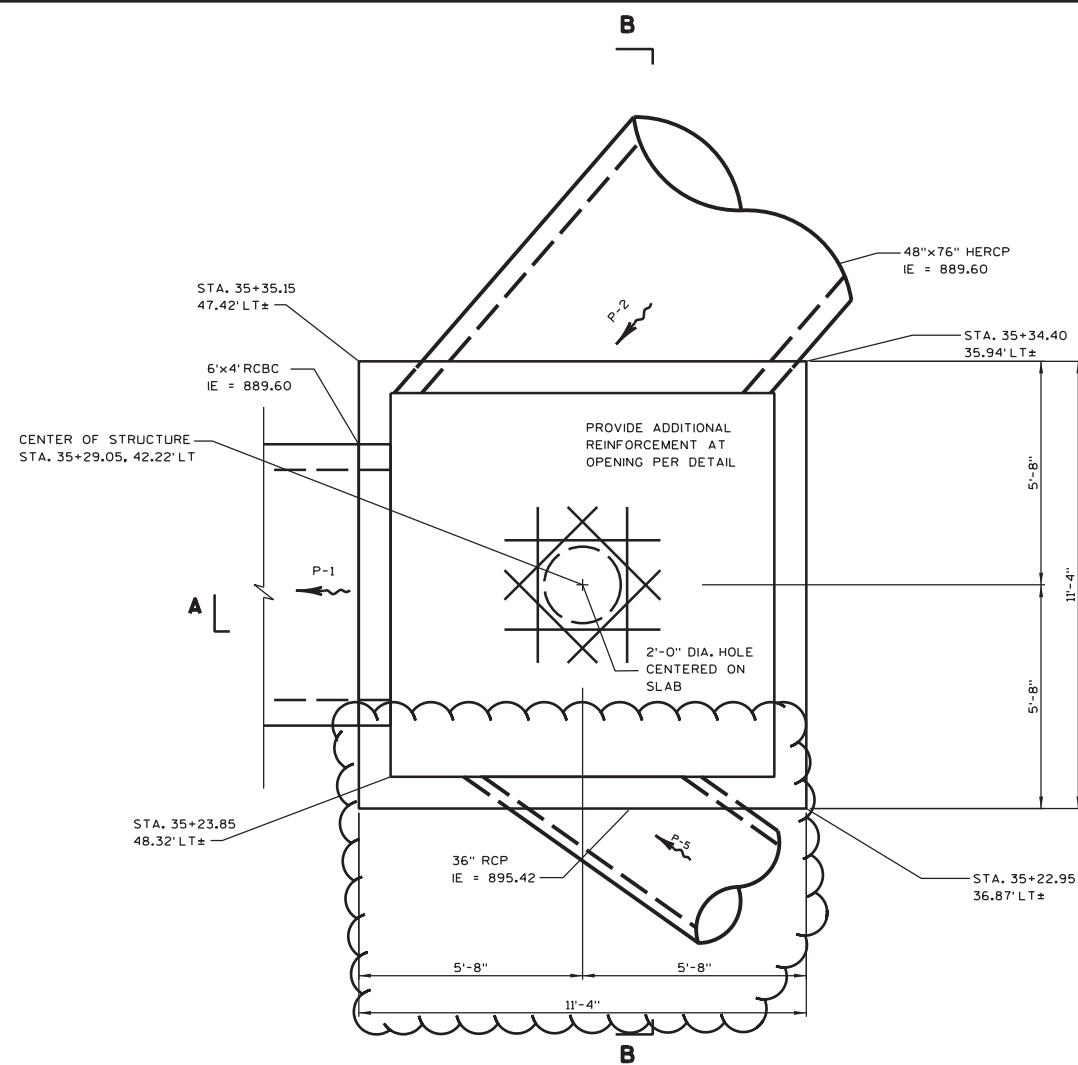

S-2 TOP PLAN

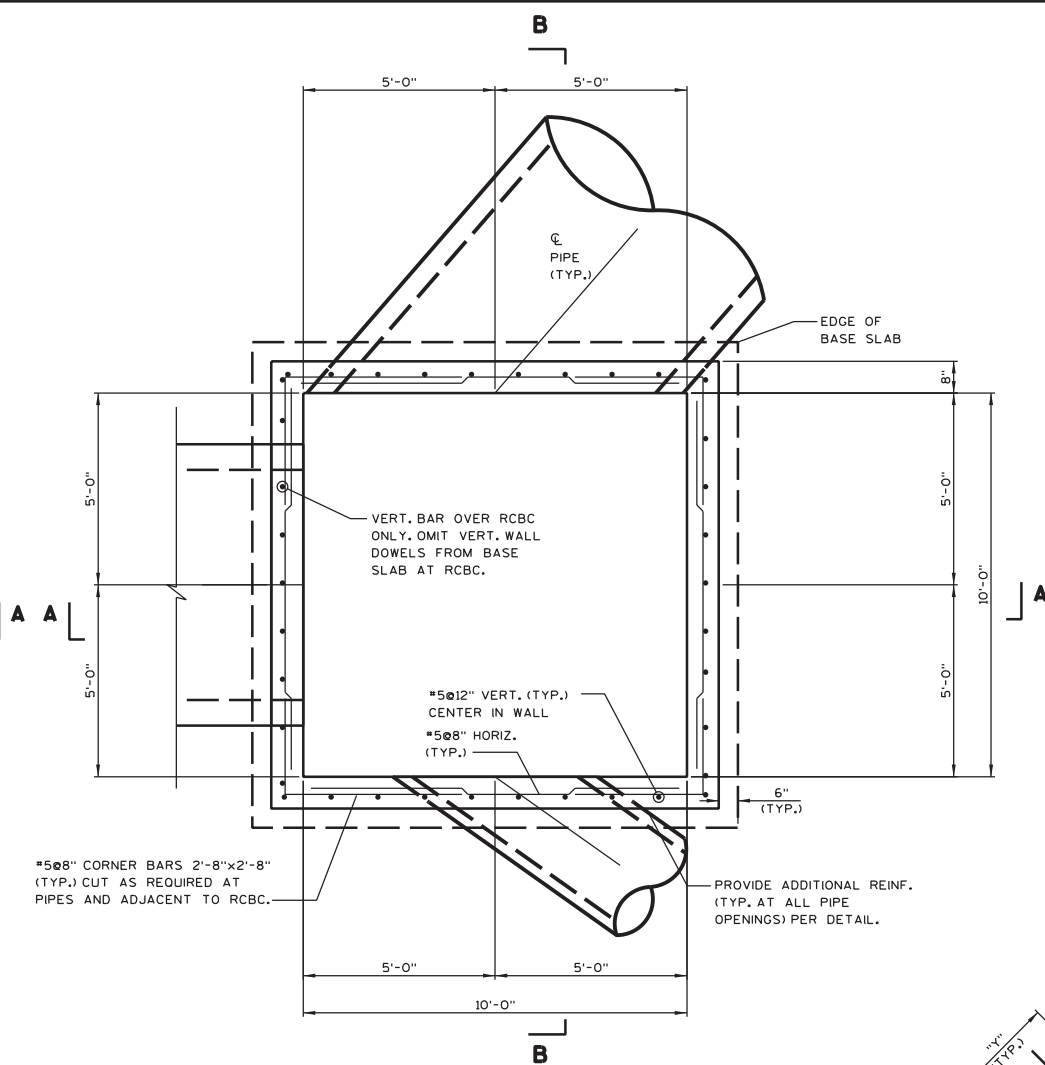

S-2 LOWER PLAN

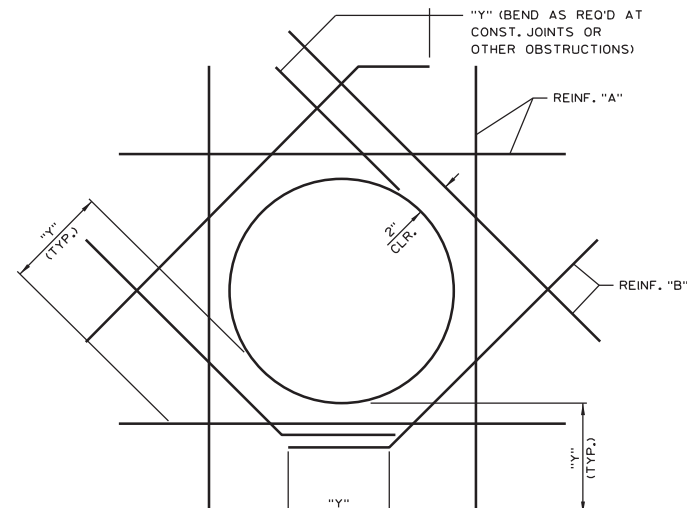

ADDITIONAL REINFORCEMENT AT CONCRETE OPENINGS

NOTES:

1. MOVE REINF. MAX. OF 2" TO CLEAR OPENING TO AVOID CUTTING REINF. CUT REMAINING BARS THAT PASS THROUGH OPENING.
2. WHERE REINF. MUST BE CUT, ADD REINF. "A" AT LEAST EQUAL IN AREA TO THAT WHICH WAS CUT AND EXTEND BEYOND OPENING DISTANCE "Y".
3. DIAGONAL BARS "B" TO BE PLACED:
A. AT EACH FACE OF WALL WHERE TWO LAYERS OF REINF. ARE PROVIDED.
B. AT TOP & BOTTOM OF ALL SLABS.
4. UNLESS OTHERWISE NOTED, SIZE OF REINF. "B" SHALL BE THE SIZE OF THE LARGEST REINF. BAR CUT.
5. Y = CLASS B LAP (#5 BAR = 1'-10")
6. THIS DETAIL IS TO BE USED WHEN NO OTHER DETAIL IS SPECIFIED.

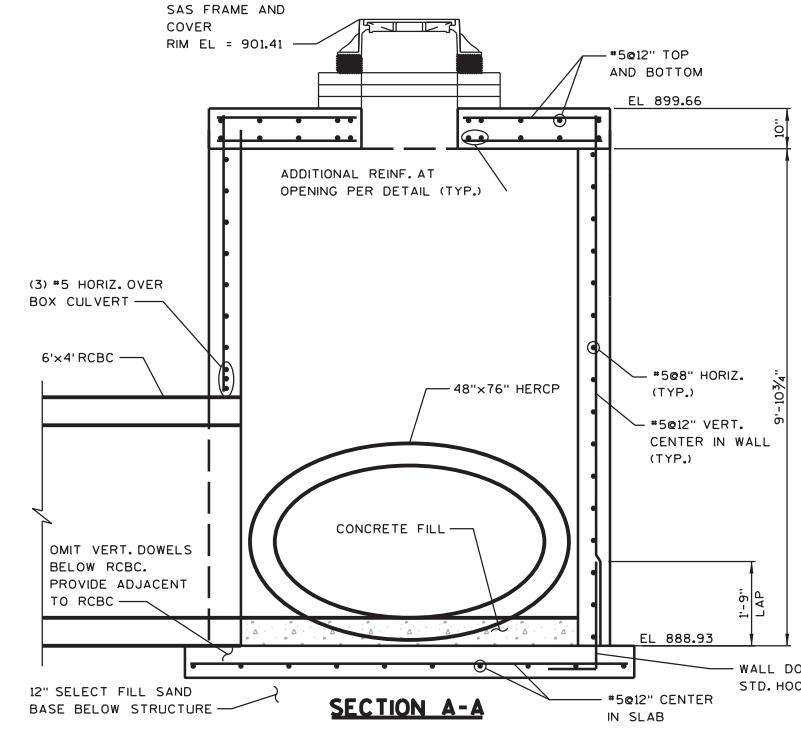

SECTION A-A

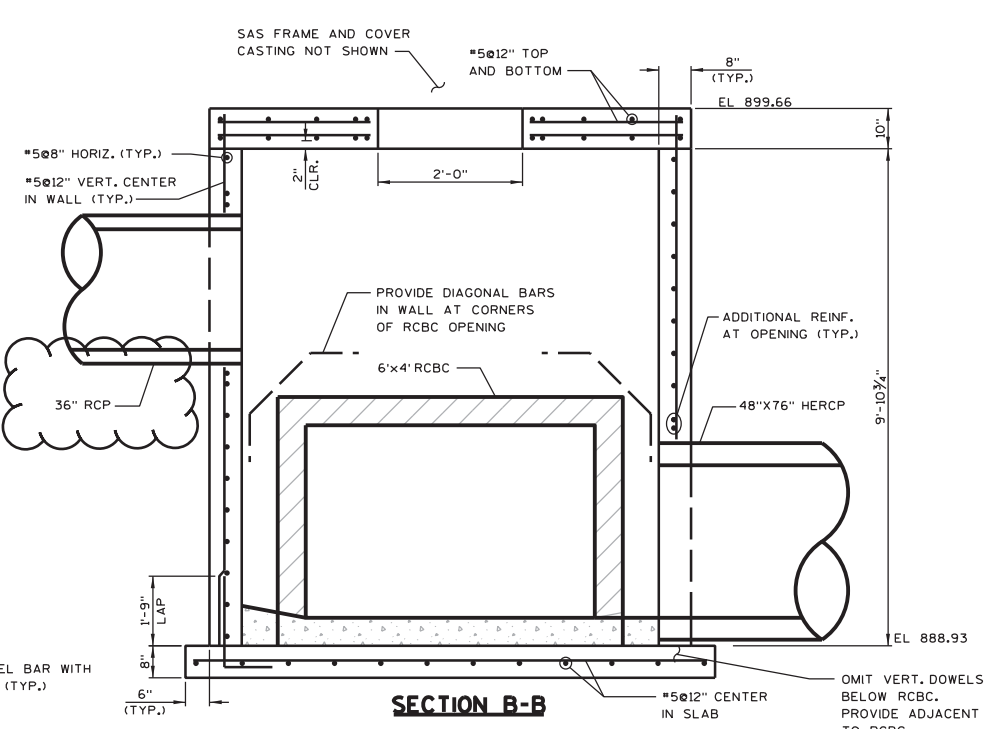

SECTION B-B

PLOT SCALE: PLOT NAME: REV. DATE: ORIGINATOR: CITY OF MADISON, STREETS DIVISION

GENERAL NOTES

ALL BAR STEEL REINFORCEMENT SHALL BE EMBEDDED 2 INCHES CLEAR UNLESS OTHERWISE SHOWN OR NOTED.

ALL ITEMS SHOWN IN THIS DETAIL, EXCEPT STORM SEWER PIPES, ARE INCLUDED IN BID ITEM "STORM SAS-SPECIAL".

CONTRACTOR MAY CHOOSE TO PRECAST TOP SLAB AND LIFT SLAB ONTO STRUCTURE. IF TOP SLAB IS NOT CAST IN PLACE, USE THE ALTERNATE SLAB JOINT DETAIL SHOWN IN DETAIL "A".

REFER TO STORM SEWER PLANS FOR PIPE SIZES, INVERT ELEVATIONS AND STATION/OFFSET TO CENTER OF STRUCTURE.

REINFORCING STEEL SHALL MEET REQUIREMENTS OF WISDOT STANDARD SPECIFICATIONS SECTION 505.

REFER TO SHEET S-5 FOR "ADDITIONAL REINFORCING AT CONCRETE OPENING" DETAIL.

EXCAVATION FOR STRUCTURE SHALL BE BACKFILLED WITH SELECT FILL SAND.

DESIGN DATA:
 CONCRETE MASONRY: $f'_c = 4000$ PSI
 STEEL REINFORCING: $F_y = 60$ KSI

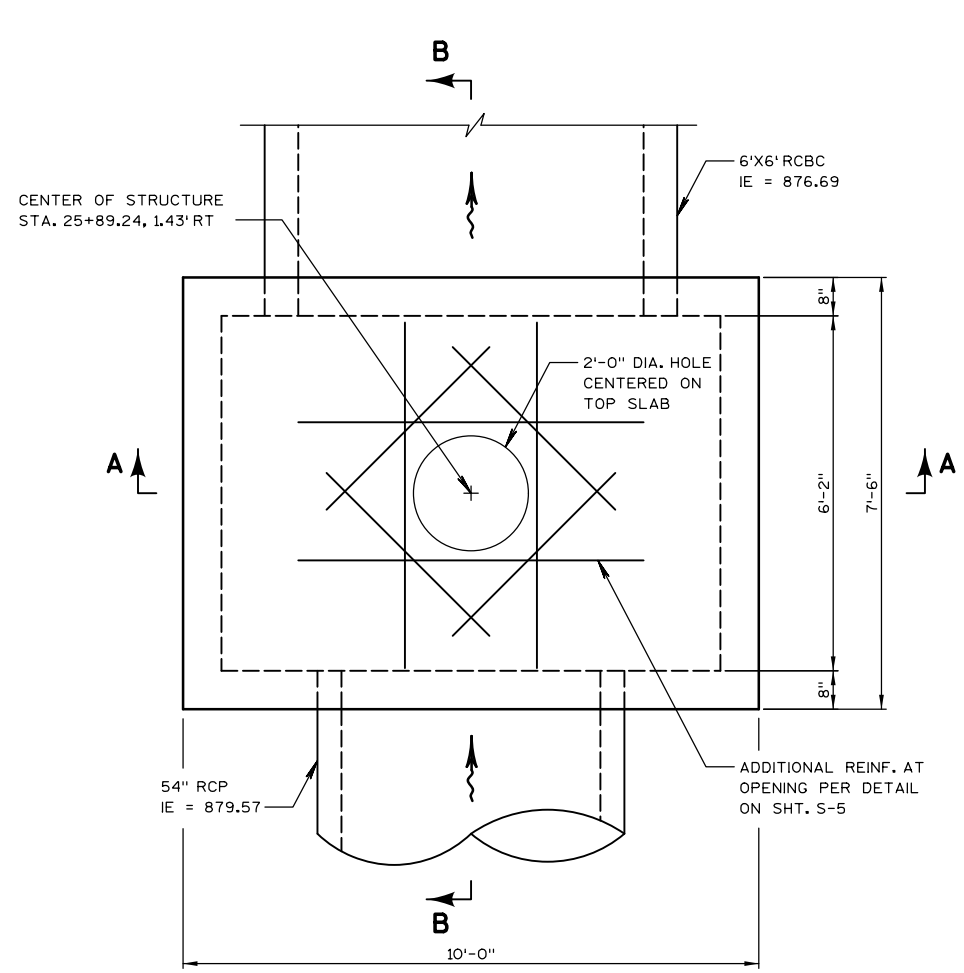

S-110 TOP PLAN

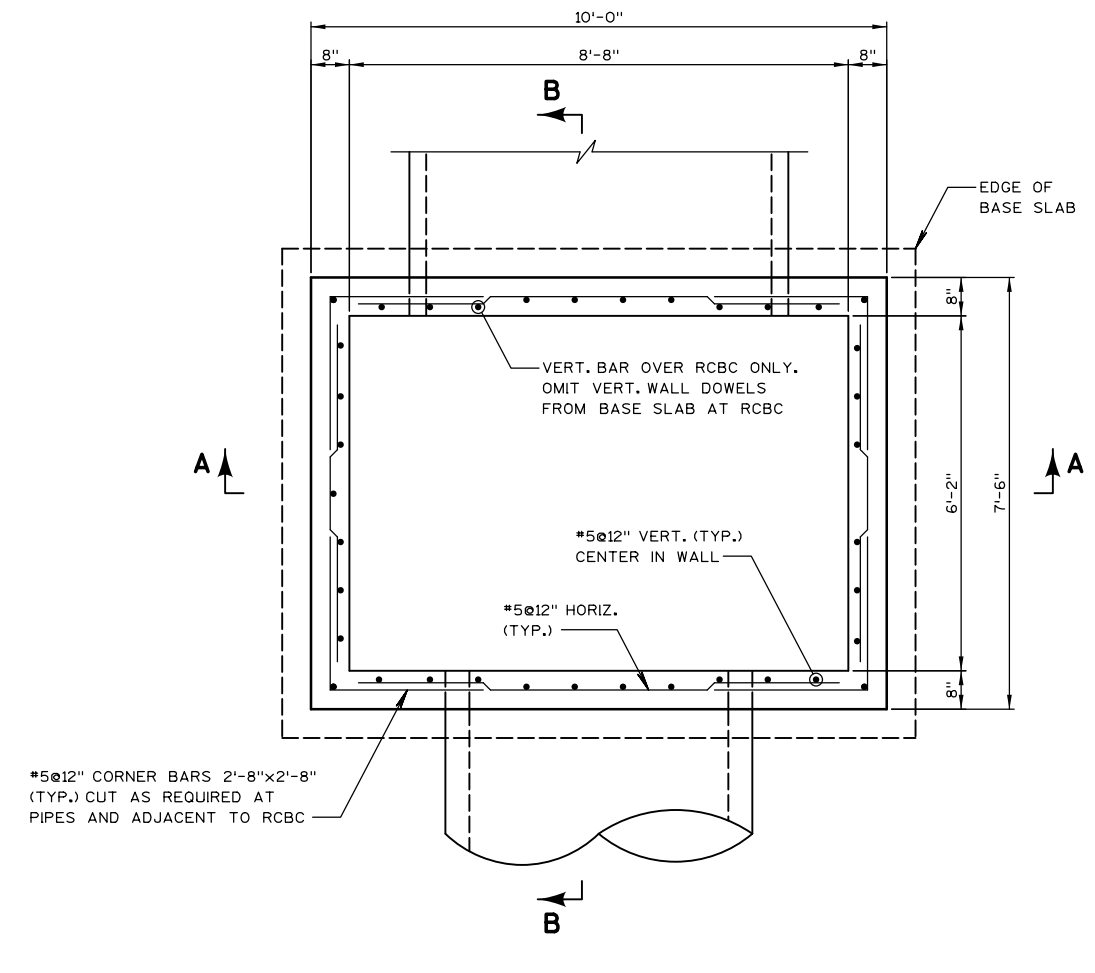

S-110 LOWER PLAN

JOINTS TO BE SEALED WITH A BUTYL RUBBER SEAL PER SEALANT MANUFACTURERS RECOMMENDATIONS CONFORMING TO ASTM C 990 (TYP.)

MASONRY ANCHOR TYPE L NO. 5 BARS, 16 INCHES LONG AT 4 CORNERS OF SLAB, CENTER DRILLED DOWEL IN WALL, HOLD DOWN 2 INCHES AND GROUT HOLE OVER ANCHOR.

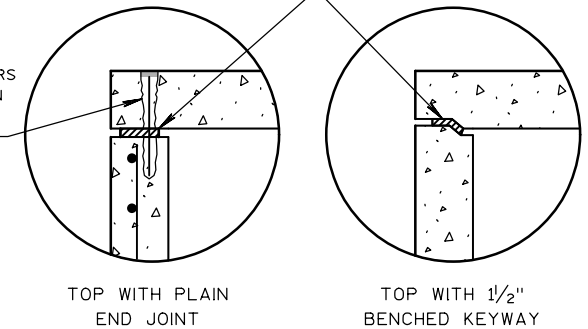

DETAIL "A"
FOR USE WITH PRECAST TOP SLAB

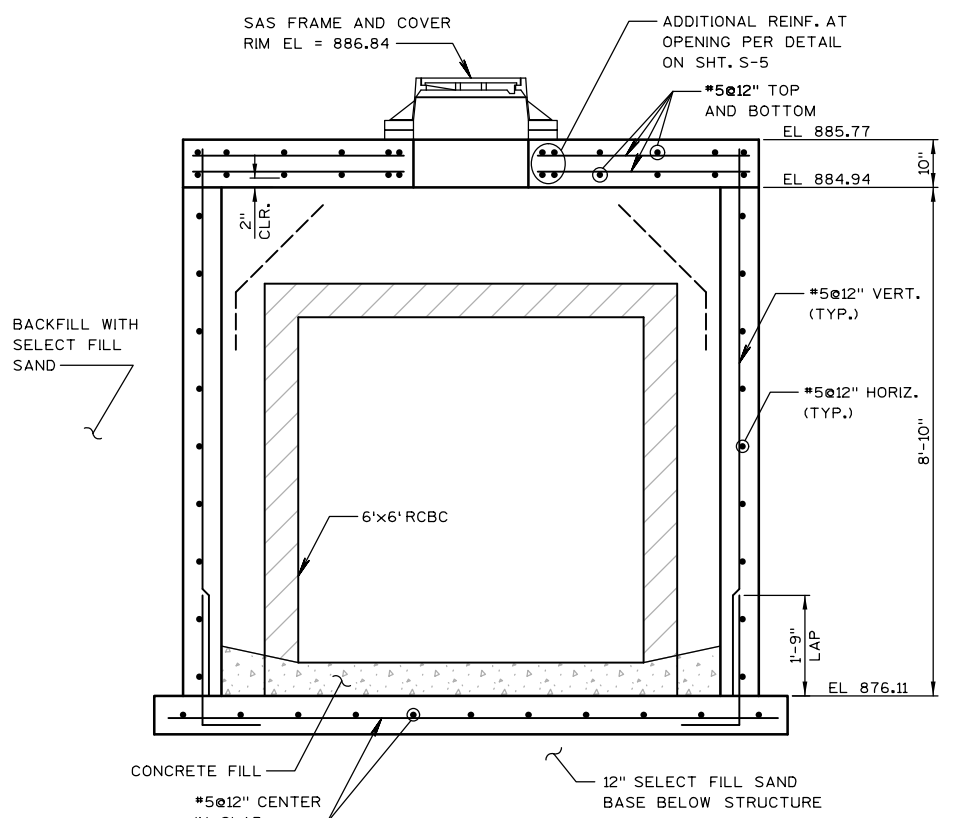

SECTION A-A

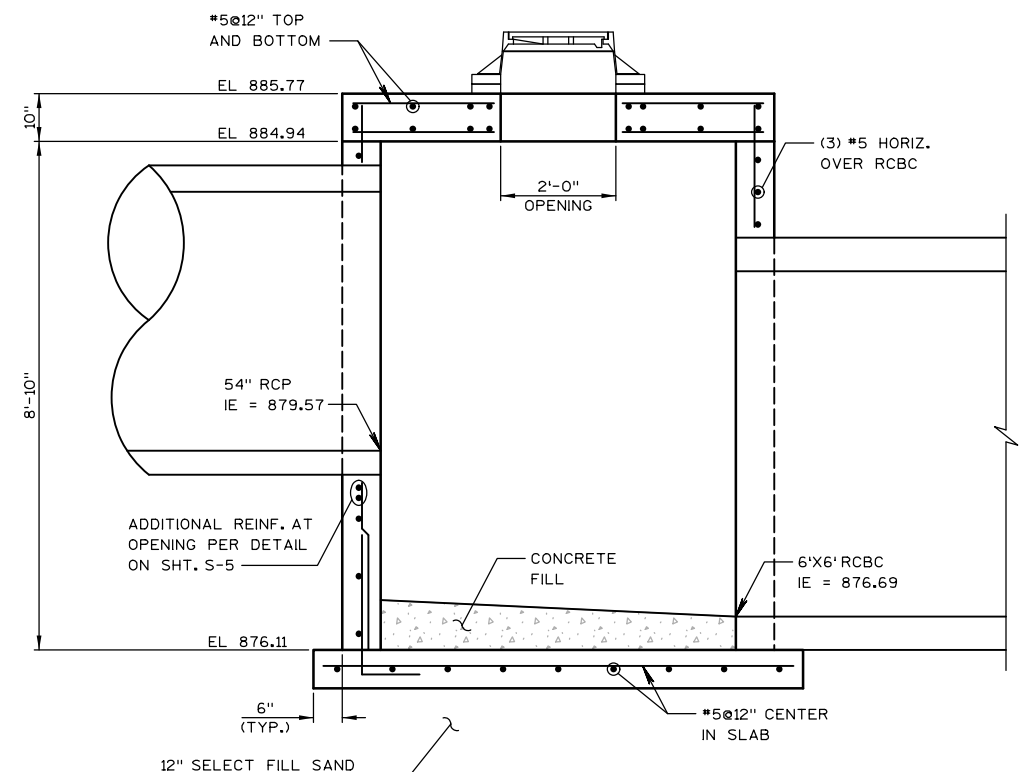

SECTION B-B

**STORM SAS-SPECIAL
 S-110 PLAN AND DETAILS**
 CITY VIEW DRIVE BOX CULVERT
 CITY OF MADISON
 MADISON, WISCONSIN

JOB NO.
1020.115
 PROJECT MGR.
BMO



SHEET
S-6

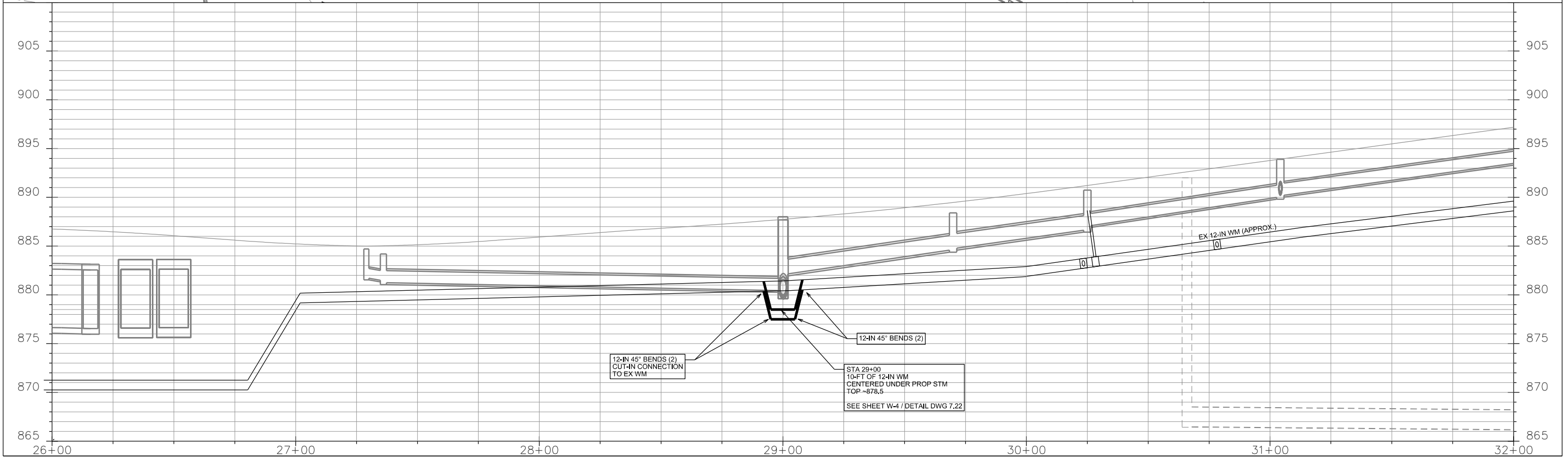
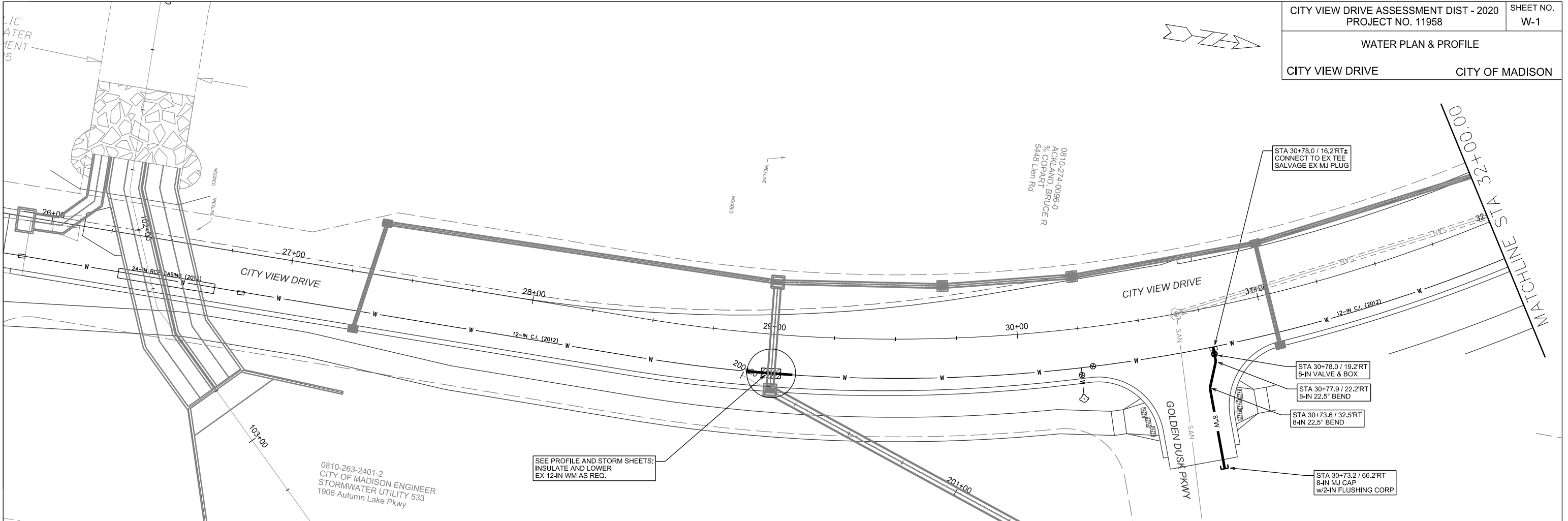

WATER PLAN & PROFILE

CITY VIEW DRIVE CITY OF MADISON

REVISED 10.07.2020
PEH

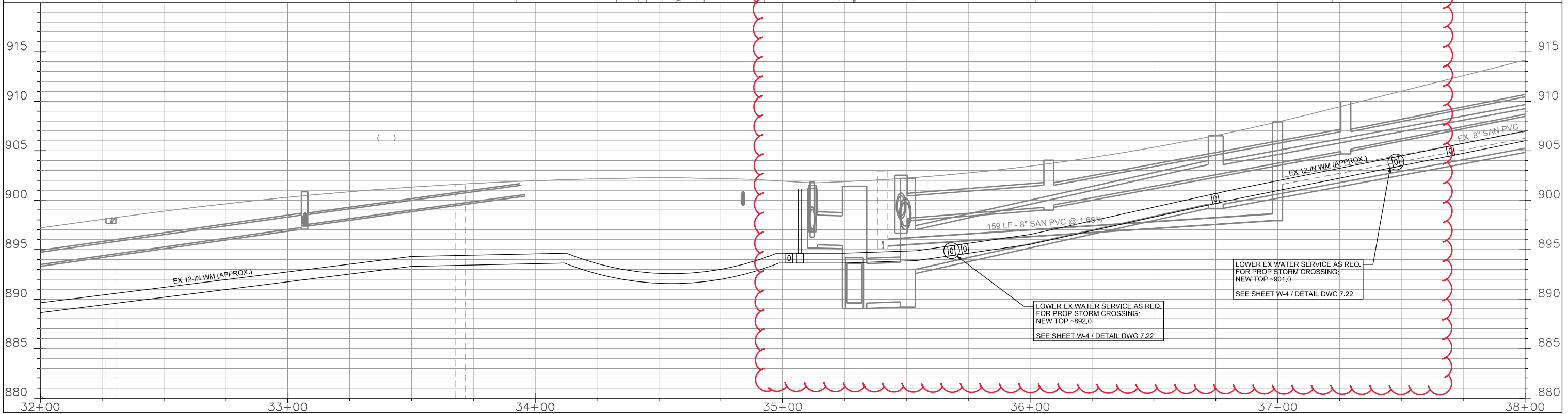
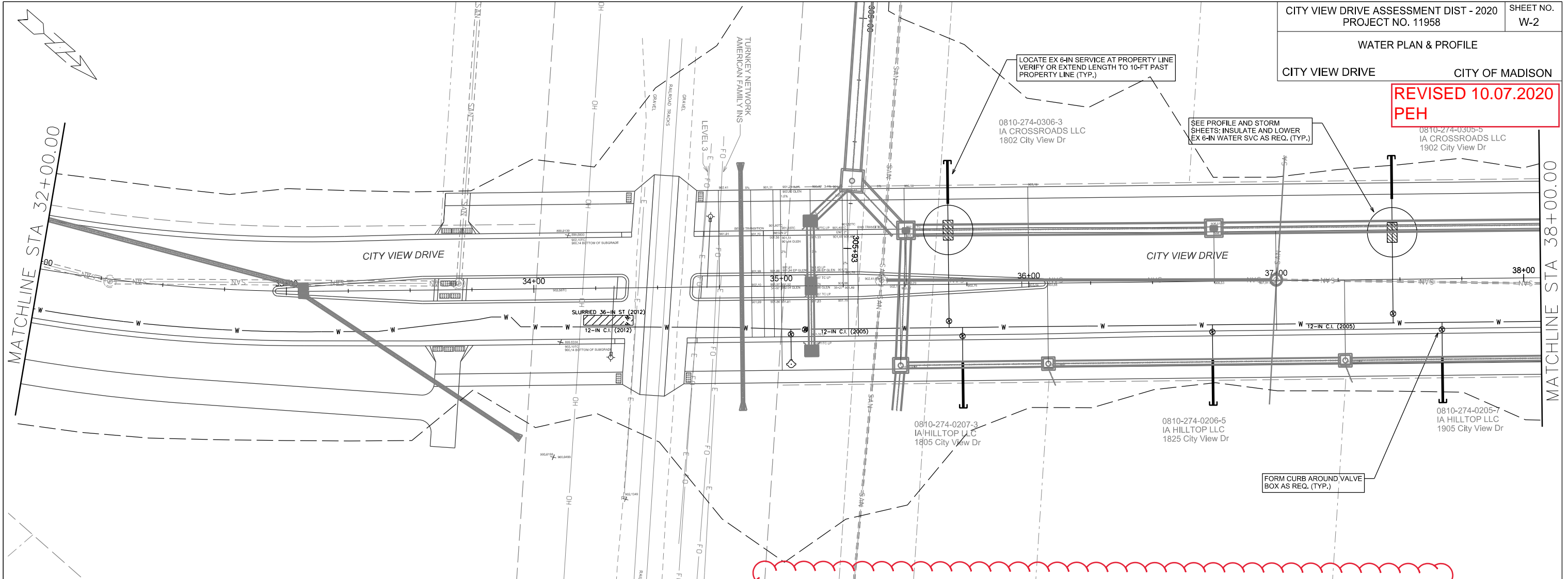

PLOT SCALE: _____

PLOT NAME: _____

REV. DATE: _____

ORIGINATOR: CITY OF MADISON, STREETS DIVISION

REVISED 10.07.2020
PEH

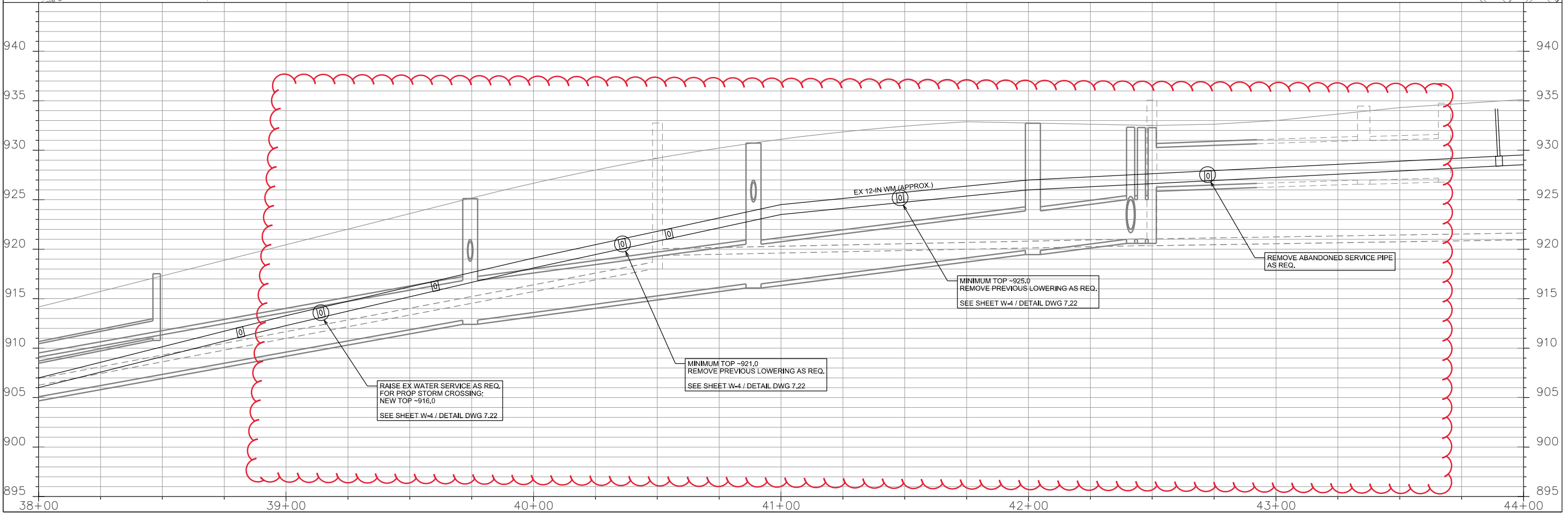
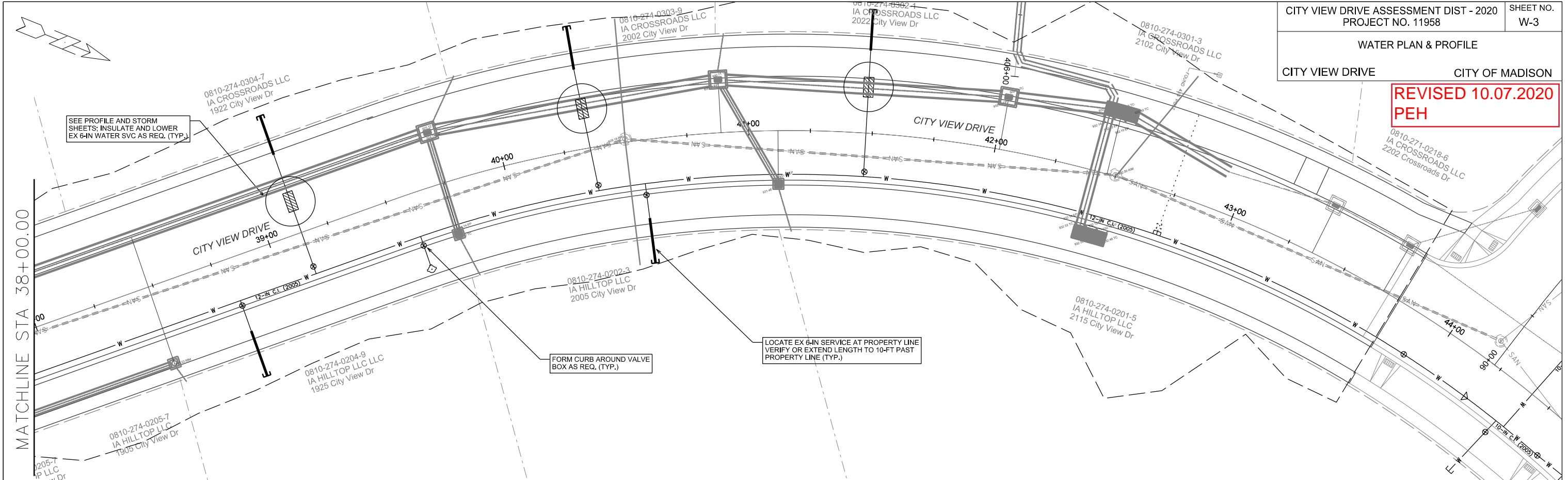

PLOT NAME: _____

REV. DATE: _____

ORIGINATOR: CITY OF MADISON, STREETS DIVISION

CONSTRUCTION NOTES:

1. CONSTRUCT NEW WATER MAIN BELOW FINISHED GRADE AS NOTED ON THE PLANS. INSULATE MAIN WITH POLYSTYRENE BOARD AT UTILITY CROSSINGS OR OTHER AREAS IDENTIFIED BY ENGINEER AS HAVING INADEQUATE COVER.
 2. VERIFY SIZE OF EXISTING WATER SERVICES AND RECONNECT SERVICES AS INDICATED.
 3. MINIMIZE DISRUPTION OF SERVICE TO EXISTING CUSTOMERS. NOTIFY PER CONTRACT REQUIREMENTS OF ANY PLANNED WATER OUTAGE.
 4. THE EXISTING UTILITIES SHOWN ON THIS PLAN REPRESENT THE BEST INFORMATION AVAILABLE TO THE WATER UTILITY AT THE TIME OF PLAN PREPARATION. CONTRACTOR IS RESPONSIBLE FOR HAVING EACH UTILITY LOCATED PRIOR TO COMMENCING WORK.
- WN1 REPLACE THE EXISTING LEAD SERVICE WITH A NEW COPPER SERVICE.
 - WN2 EXTEND AND RECONNECT THE EXISTING COPPER SERVICE FROM THE OLDER WATER MAIN TO THE NEWER WATER MAIN.
 - WN3 EXISTING SERVICE TO BE ABANDONED WHEN THE WATER MAIN IS CUT OFF; ABANDON CURB BOX AS REQUIRED.
 - WN4 DISCONNECT FROM THE OLDER WATER MAIN AND RECONNECT THE EXISTING COPPER WATER SERVICE LATERAL TO THE NEWER WATER MAIN.
 - WN5 RELOCATE THE EXISTING FIRE HYDRANT.
 - WN6 ABANDON WATER VALVE ACCESS STRUCTURE.
 - WN7 FURNISH AND INSTALL THE NEW TOP SECTION FOR THE WATER ACCESS STRUCTURE.
 - WN8 ABANDON THE VALVE BOX.
 - WN9 FURNISH THE DITCH, COMPACTION, AND ALL MATERIALS AND LABOR FOR THE INSTALLATION OF NEW SERVICE LATERAL.
 - WN10 REMOVE AND SALVAGE EXISTING HYDRANT
 - WN11 REPLACE THE EXISTING COPPER SERVICE WITH A COPPER SERVICE

ESTIMATE OF PROJECT WATER MATERIALS:

** ESTIMATE OF MATERIALS IS FOR INFORMATION ONLY. ENGINEER DOES NOT GUARANTEE ACCURACY OF MATERIAL TAKE-OFF. ALWAYS REFER TO PLANS.*

WATER MAIN / FITTING MATERIALS	
6-IN PIPE (LF)	180
8-IN PIPE (LF)	50
POLY WRAP (LF)	260
8-IN VALVES & BOXES	1
8-IN 22.5° BENDS	2
6-IN 45° BENDS	20
8-IN MJ CAPS w/2-IN CORP	1
MISC. MATERIALS	
2-IN INSULATION (LF)	AS REQ
REUSED MATERIALS	
6-IN MJ CAPS	9
SALVAGED MATERIALS	
8-IN MJ PLUGS	1

TO OBTAIN LOCATION OF PARTICIPANTS' UNDERGROUND FACILITIES BEFORE YOU DIG IN WISCONSIN

CALL DIGGERS HOTLINE TOLL FREE
811 OR 1-800-242-8511
FAX-A-LOCATE 1-800-338-3860
TDD (FOR HEARING IMPAIRED) 1-800-542-2289

WIS. STATUTE 182.0175 (1974) REQUIRES MIN. OF 3 WORK DAYS NOTICE BEFORE YOU EXCAVATE.

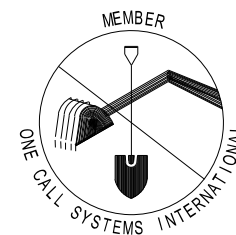

DISCLAIMER NOTE:
UTILITY LOCATIONS SHOWN ARE APPROXIMATE ONLY. IT SHALL BE THE CONTRACTOR'S RESPONSIBILITY TO DETERMINE THE EXACT HORIZONTAL AND VERTICAL LOCATION OF ALL EXISTING UNDERGROUND AND OVERHEAD UTILITIES PRIOR TO COMMENCING WORK.

PART VII - WATER MAINS AND SERVICE LATERALS

DETAIL DRAWING NO. 7.22

REVISED: 12/2018

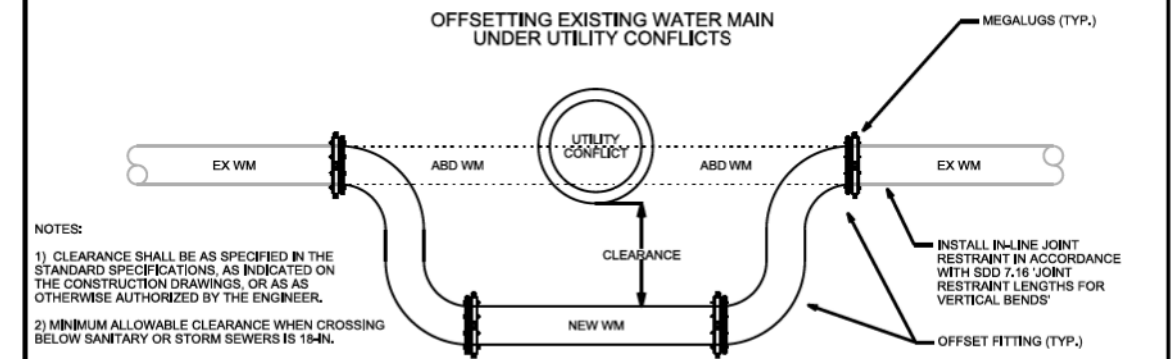

NOTES:

- 1) CLEARANCE SHALL BE AS SPECIFIED IN THE STANDARD SPECIFICATIONS, AS INDICATED ON THE CONSTRUCTION DRAWINGS, OR AS OTHERWISE AUTHORIZED BY THE ENGINEER.
- 2) MINIMUM ALLOWABLE CLEARANCE WHEN CROSSING BELOW SANITARY OR STORM SEWERS IS 18-IN.
- 3) IF REQUIRED CLEARANCE CANNOT BE OBTAINED, USE 45° FITTINGS IN LIEU OF OFFSET FITTINGS.
- 4) 11.25°, 22.5°, OR 90° FITTINGS ARE NOT ALLOWED WITHOUT ENGINEER APPROVAL.
- 5) INSULATE AS REQUIRED PER THE STANDARD SPECIFICATIONS OR AS INDICATED ON THE DRAWINGS.
- 6) FITTINGS CONNECTED TO EXISTING WATER MAINS WITH CUT-IN CONNECTIONS PER THE STANDARD SPECIFICATIONS.
- 7) NEW PIPE SHALL HAVE NO JOINTS BETWEEN FITTINGS.

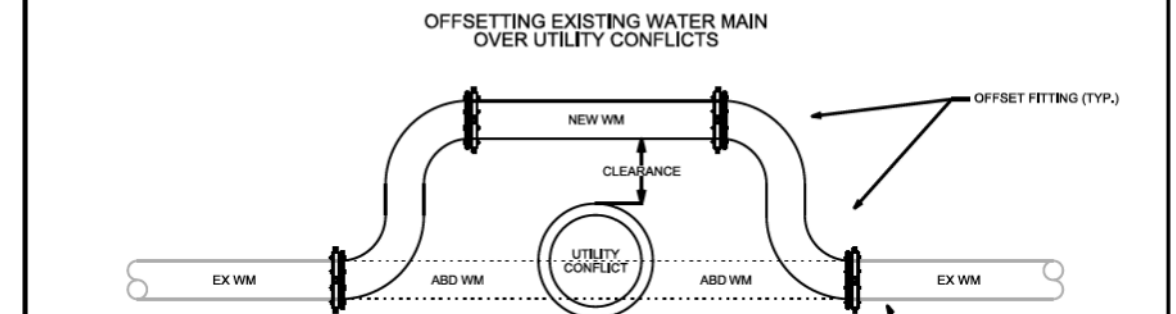

NOTES:

- 1) CLEARANCE SHALL BE AS SPECIFIED IN THE STANDARD SPECIFICATIONS, AS INDICATED ON THE CONSTRUCTION DRAWINGS, OR AS OTHERWISE AUTHORIZED BY THE ENGINEER.
- 2) MINIMUM ALLOWABLE CLEARANCE WHEN CROSSING ABOVE SANITARY OR STORM SEWERS IS 6-IN.
- 3) IF REQUIRED CLEARANCE CANNOT BE OBTAINED, USE 45° FITTINGS IN LIEU OF OFFSET FITTINGS.
- 4) 11.25°, 22.5°, OR 90° FITTINGS ARE NOT ALLOWED WITHOUT ENGINEER APPROVAL.
- 5) INSULATE AS REQUIRED PER THE STANDARD SPECIFICATIONS OR AS INDICATED ON THE DRAWINGS.
- 6) FITTINGS CONNECTED TO EXISTING WATER MAINS WITH CUT-IN CONNECTIONS PER THE STANDARD SPECIFICATIONS.
- 7) NEW PIPE SHALL HAVE NO JOINTS BETWEEN FITTINGS.

CITY OF MADISON WATER UTILITY NOT TO SCALE OFFSETTING EXISTING WATER MAIN OVER/UNDER UTILITY CONFLICTS

City of Madison Standard Specifications for Public Works Construction

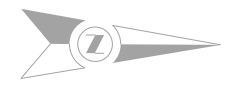

SCALE: 1" = 40'

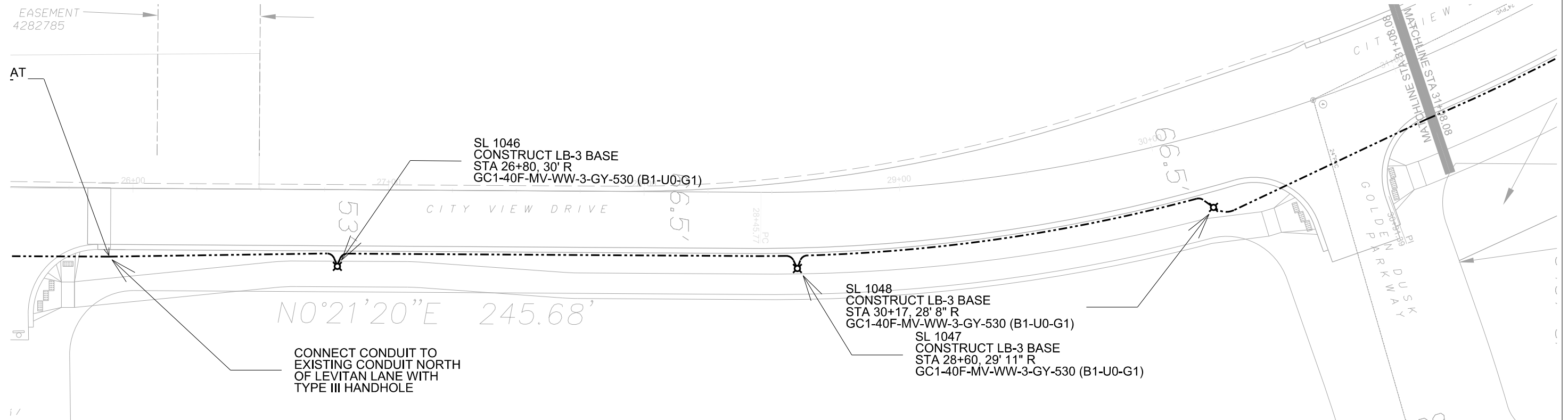

NOTES:

1. ALL LOCATIONS ARE APPROXIMATE. THE TRAFFIC ENGINEER SHALL APPROVE FINAL LOCATIONS, INCLUDING SETBACK, IN THE FIELD AFTER CONTRACTOR SURVEYS STAKING. THE CONTRACTOR SHALL NOTIFY JERRY SCHIPPA (267-1969) CITY TRAFFIC ENGINEERING, AT LEAST 24-HOURS IN ADVANCE OF NEEDING CONDUIT OR BASE LOCATIONS MARKED.
2. BASES INSTALLED IN TERRACE SHALL BE 4' FROM BACK OF CURB UNLESS OTHERWISE NOTED. SUBJECT TO NOTE 1 ABOVE.
3. THE CONTRACTOR SHALL DO ALL WORK IN ACCORDANCE WITH "CITY OF MADISON STANDARD SPECIFICATIONS FOR PUBLIC WORKS CONSTRUCTION, 2020 EDITION" AND ALL ADDENDUMS THERETO. ALL CONDUIT SHALL BE PVC, SCHEDULE 80 UNDER PAVEMENT OR SCHEDULE 40 OTHERWISE. PULL WIRE REQUIRED AS PER STANDARD SPECIFICATIONS.
4. THE CONTRACTOR SHALL CALL MIKE BENZSCHAWEL (266-9031) AT THE TRAFFIC ENGINEERING SHOP AT LEAST 24-HOURS IN ADVANCE OF POURING BASES OR BURYING CONDUIT TO ARRANGE FOR INSPECTION.
5. ANY WORK COMPLETED WITHOUT INSPECTION IS SUBJECT TO REJECTION.
6. CONTRACTOR SHALL INSTALL ALL NEW BASES, CONDUIT AND HANDHOLE, PER SHEETS E-1 TO E-4.
7. THE CONTRACTOR SHALL ARRANGE FOR PICK UP OF THE FOLLOWING CITY FURNISHED MATERIALS, WHICH SHOULD BE ARRANGED FOR PICKUP BY CALLING DENNIS ROWE, TRAFFIC ENGINEERING SHOP, 266-9034 1120 SAYLE ST, AT LEAST 24-HOURS PRIOR TO NEEDING MATERIALS:
 - (40) 1" x 40" Anchor Bolts

LEGEND

- CONSTRUCT LB-3 BASE
- 2-INCH ELECTRICAL CONDUIT (UNLESS OTHERWISE NOTED)
- CONSTRUCT ELECTRICAL HANDHOLE TYPE 1
- CONSTRUCT ELECTRICAL HANDHOLE TYPE 3
- EXISTING MG&E POLE

PLOT SCALE:

PLOT NAME:

REV. DATE:

ORIGINATOR: CITY OF MADISON, TRAFFIC ENG. DIV.

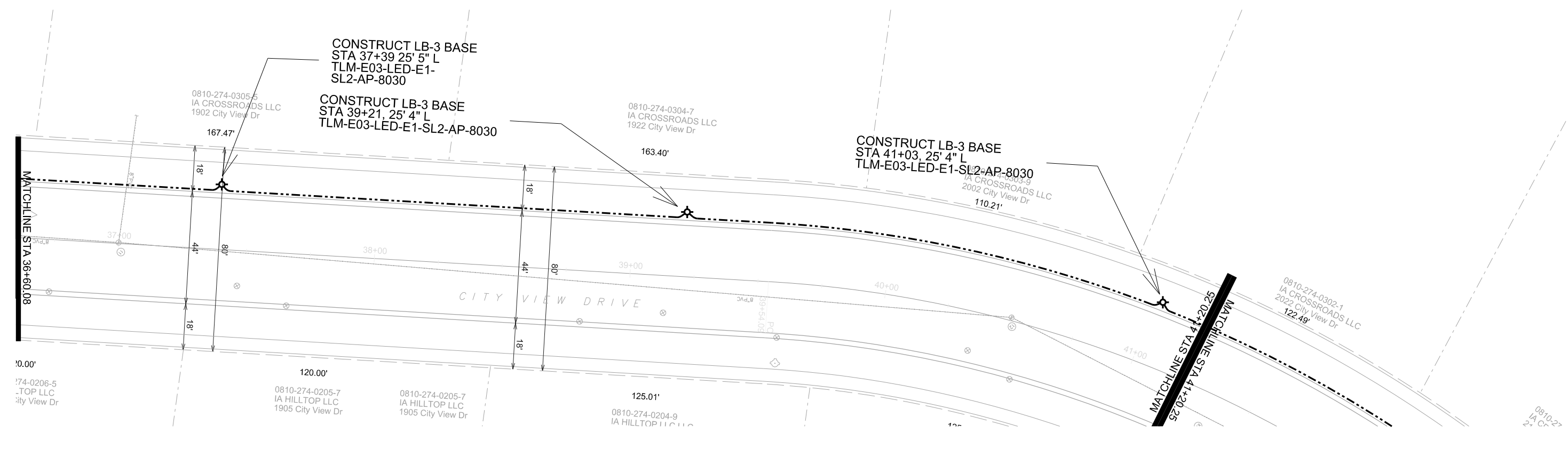
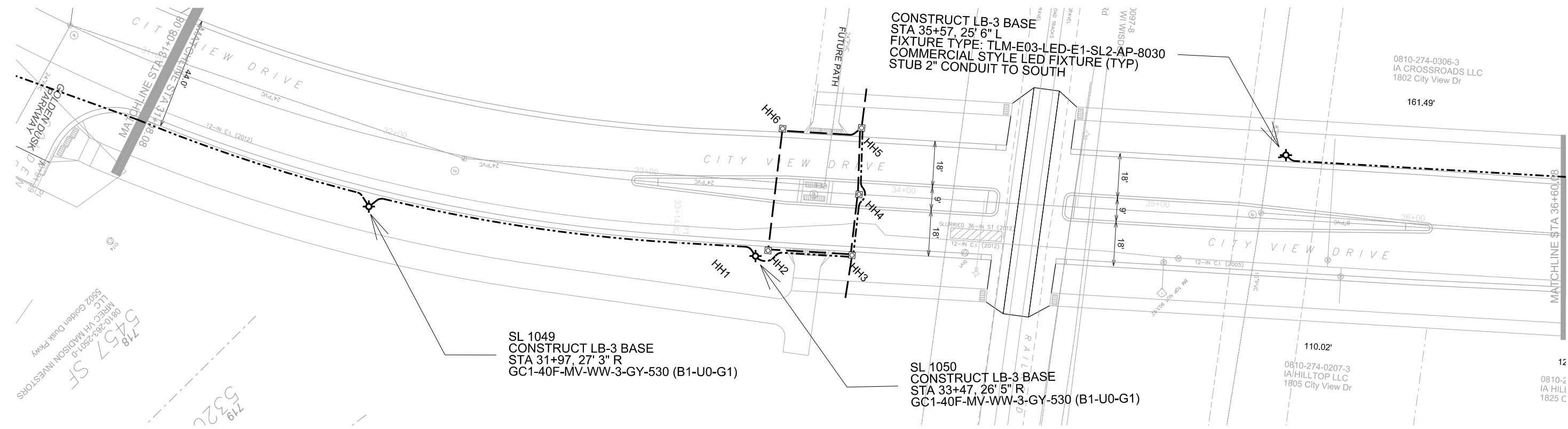
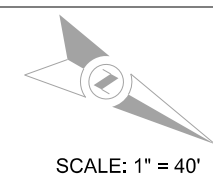

PLOT SCALE:

PLOT NAME:

REV. DATE:

ORIGINATOR: CITY OF MADISON, TRAFFIC ENG. DIV.

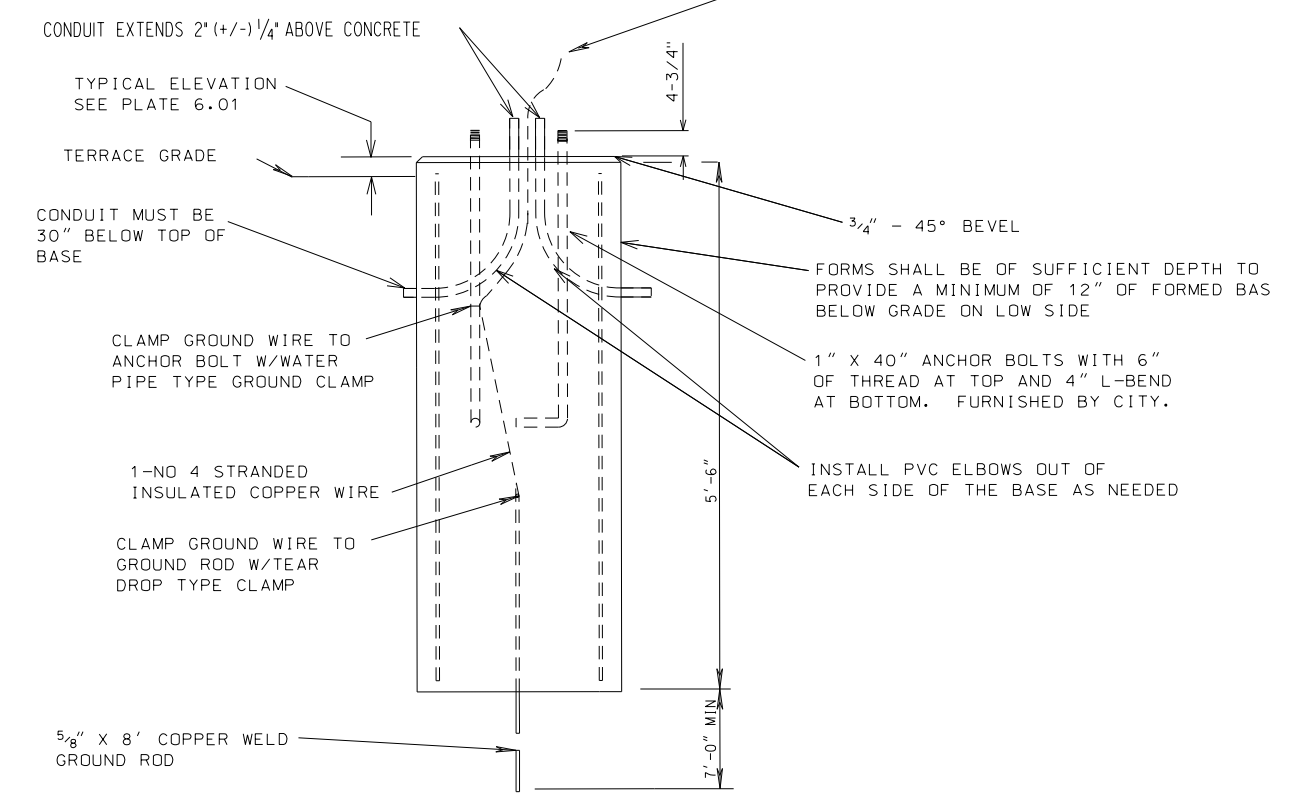
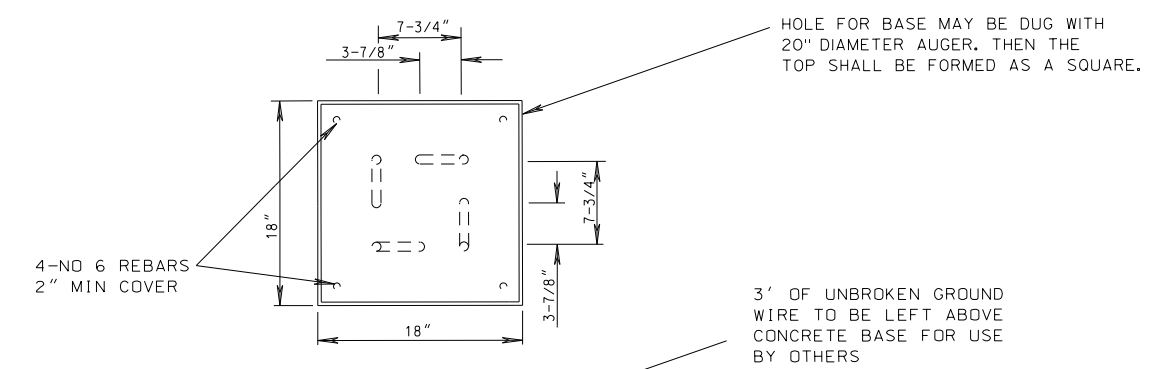
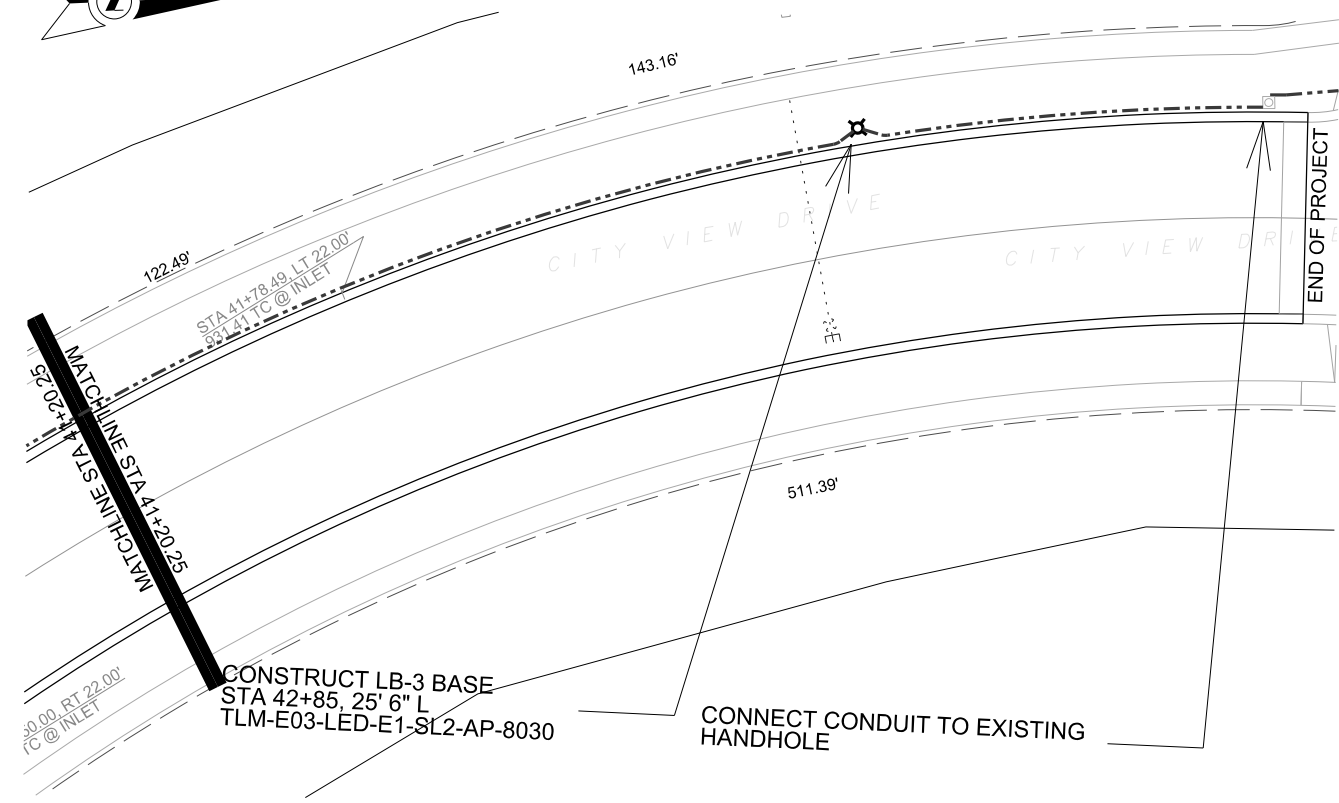

DETAIL: TYPE 2 HANDHOLE
SCALE: NONE

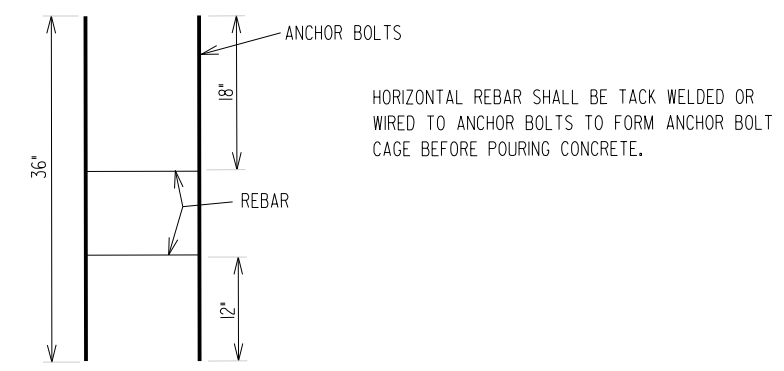
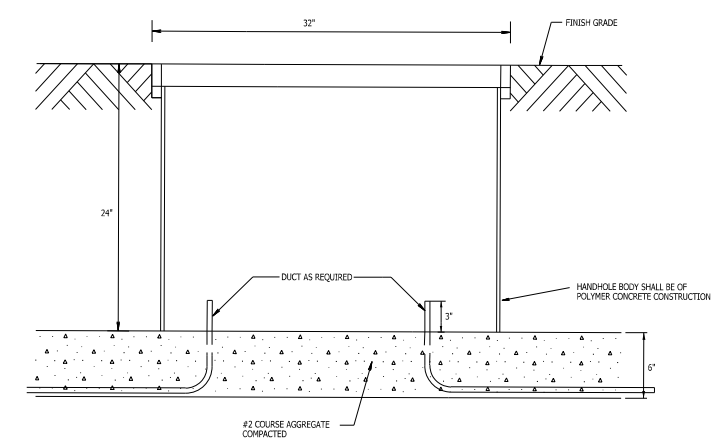
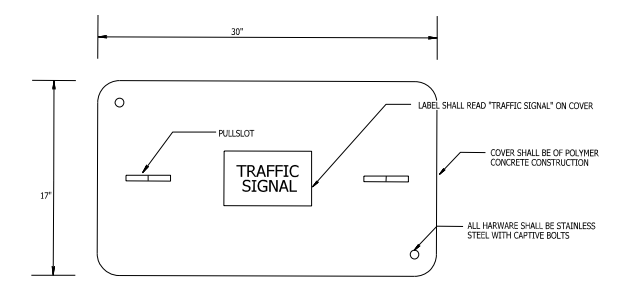

DETAIL: LB-3 BASE
SCALE: NONE

PLOT SCALE:

PLOT NAME:

REV. DATE:

ORIGINATOR: CITY OF MADISON, TRAFFIC ENG. DIV.

60230 60232 60261
FURNISH & INSTALL 2-IN PVC ELECTRICAL TRENCH

60403 60703
CONSTRUCT LB-3 BASE CONSTRUCT TYPE II HANDHOLE

FROM	TO	SCH 40 (LF)	SC 80 (LF)	(LF)	Comments
EXISTING	SL1046	92	-	92	(1) - 2"
SL1046	SL1047	186	-	186	(1) - 2"
SL1047	SL1048	169	-	169	(1) - 2"
SL1048	SL1049	-	189	189	(1) - 2"
SL1049	SL1050	155	-	155	(1) - 2"
SL1050	HH3	39	-	39	(1) - 2"
HH3	END	17	-	17	(1) - 2"
HH3	HH2	33	-	-	(1) - 2"
HH2	HH6	-	48	48	(1) - 2"
HH3	HH4	-	25	-	(1) - 2"
HH4	HH5	-	25	-	(1) - 2"
HH3	HH5	-	50	50	(1) - 2"
HH6	HH5	32	-	32	(1) - 2"
HH5	END	17	-	17	(1) - 2"
SL1051	SL1052	190	-	190	(1) - 2"
SL1052	SL1053	182	-	182	(1) - 2"
SL1053	SL1054	191	-	191	(1) - 2"
SL1054	SL1055	193	-	193	(1) - 2"
SL1055	EXISTING HH	87	-	87	(1) - 2"
TOTALS		1583	337	1837	

DESCRIPTION	STATION	OFFSET	(EACH)	(EACH)
SL1046	26+80	30' R	1	-
SL1047	28+60	30' R	1	-
SL1048	30+17	28.5' R	1	-
SL1049	31+97	27.5' R	1	-
SL1050	33+47	26.5' R	1	-
HH2	33+52	24' R	-	1
HH6	33+52	24' L	-	1
HH3	33+83	24' R	-	1
HH5	33+83	24' L	-	1
HH4	33+83	0' R	-	1
SL1051	35+57	25.5' L	1	-
SL1052	37+39	25.5' L	1	-
SL1053	39+21	25.5' L	1	-
SL1054	41+03	25.5' L	1	-
SL1055	42+85	25.5' L	1	-
TOTALS			10	5

PLOT SCALE:

PLOT NAME:

REV. DATE:

ORIGINATOR: CITY OF MADISON, TRAFFIC ENG. DIV.

PLOT SCALE:

PLOT NAME:

REV. DATE:

ORIGINATOR: CITY OF MADISON, TRAFFIC ENG. DIV.

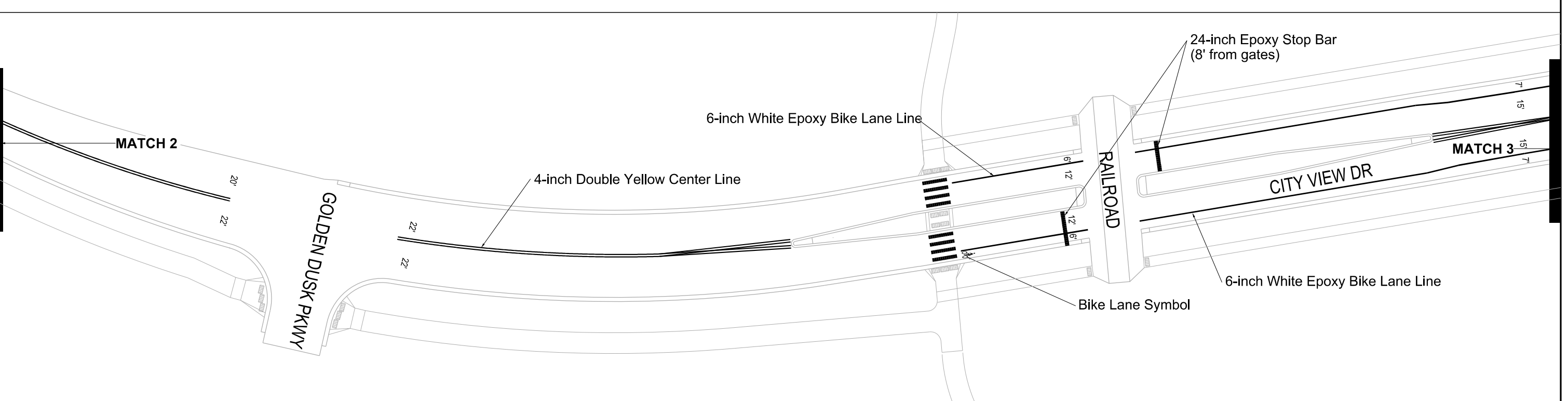
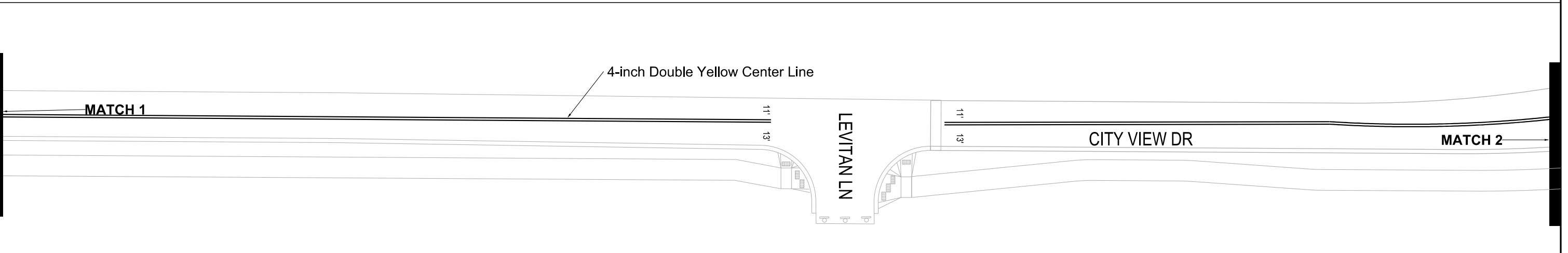
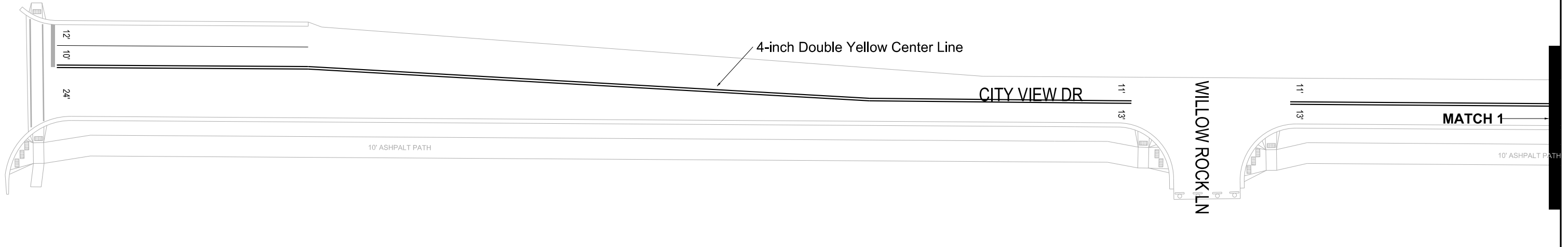

PLOT SCALE:

PLOT NAME:

REV. DATE:

ORIGINATOR: CITY OF MADISON, TRAFFIC ENG. DIV.



CROSS SECTIONS

CITY VIEW DRIVE

CITY OF MADISON

PLOT SCALE: _____

PLOT NAME: _____

REV. DATE: _____

ORIGINATOR: CITY OF MADISON, STREETS DIVISION

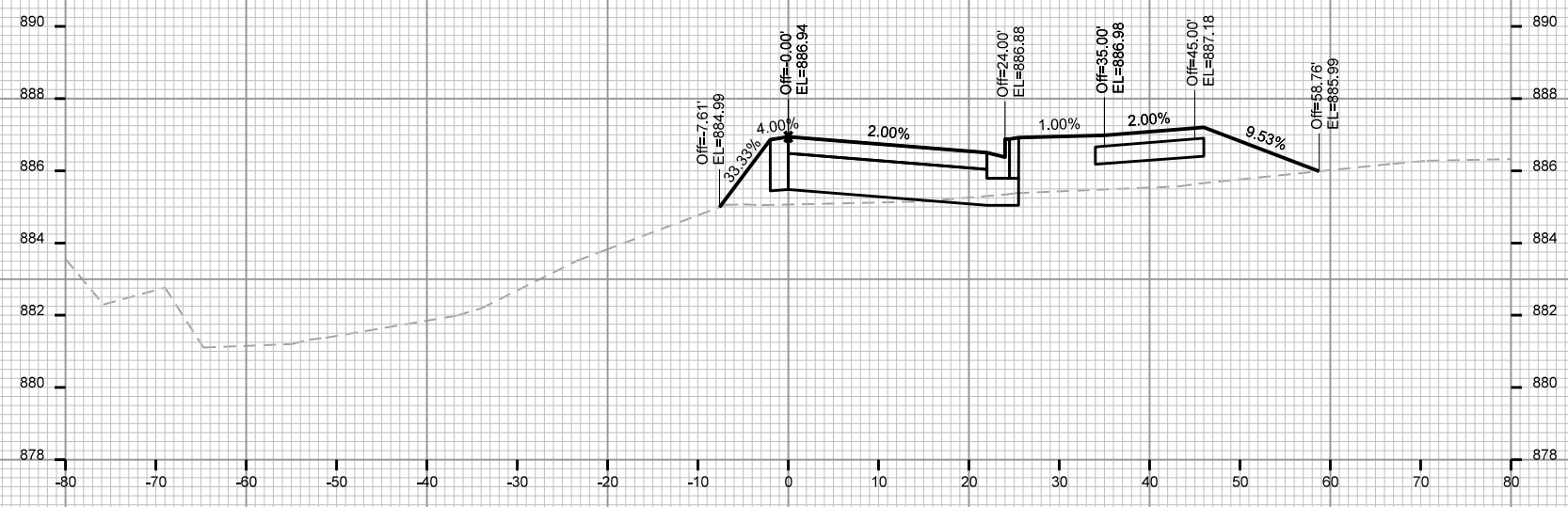
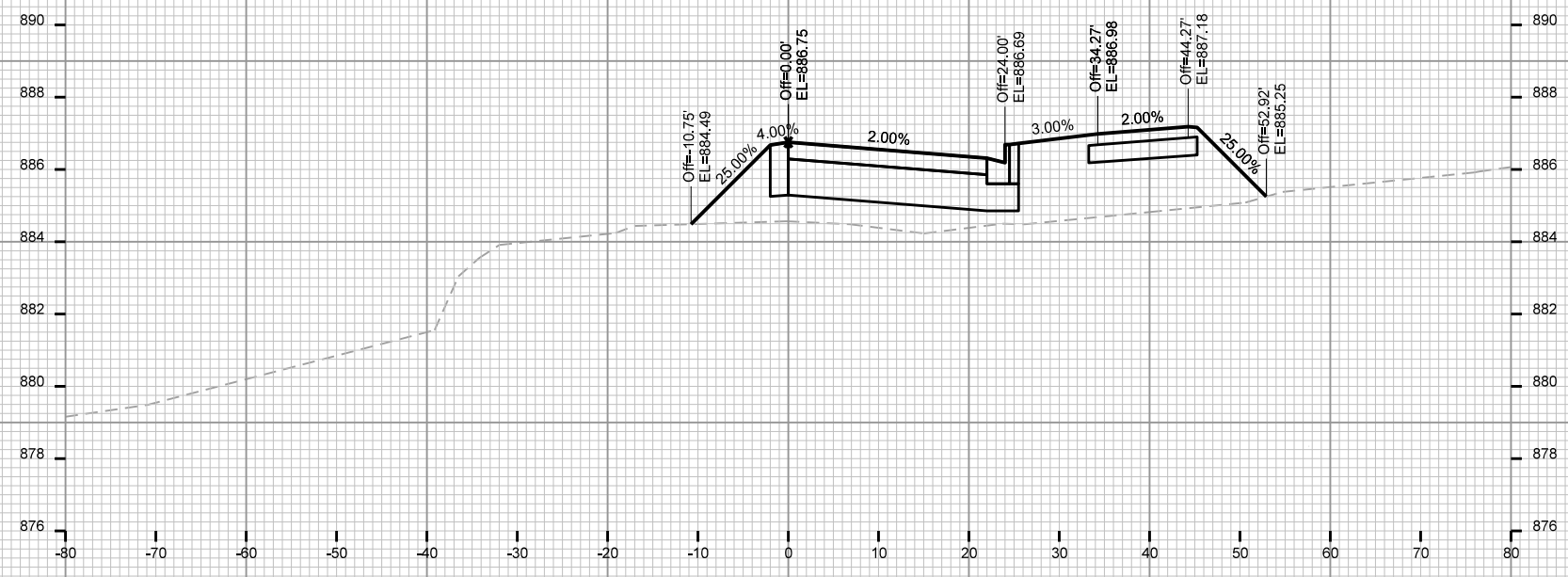

CROSS SECTIONS

CITY VIEW DRIVE

CITY OF MADISON

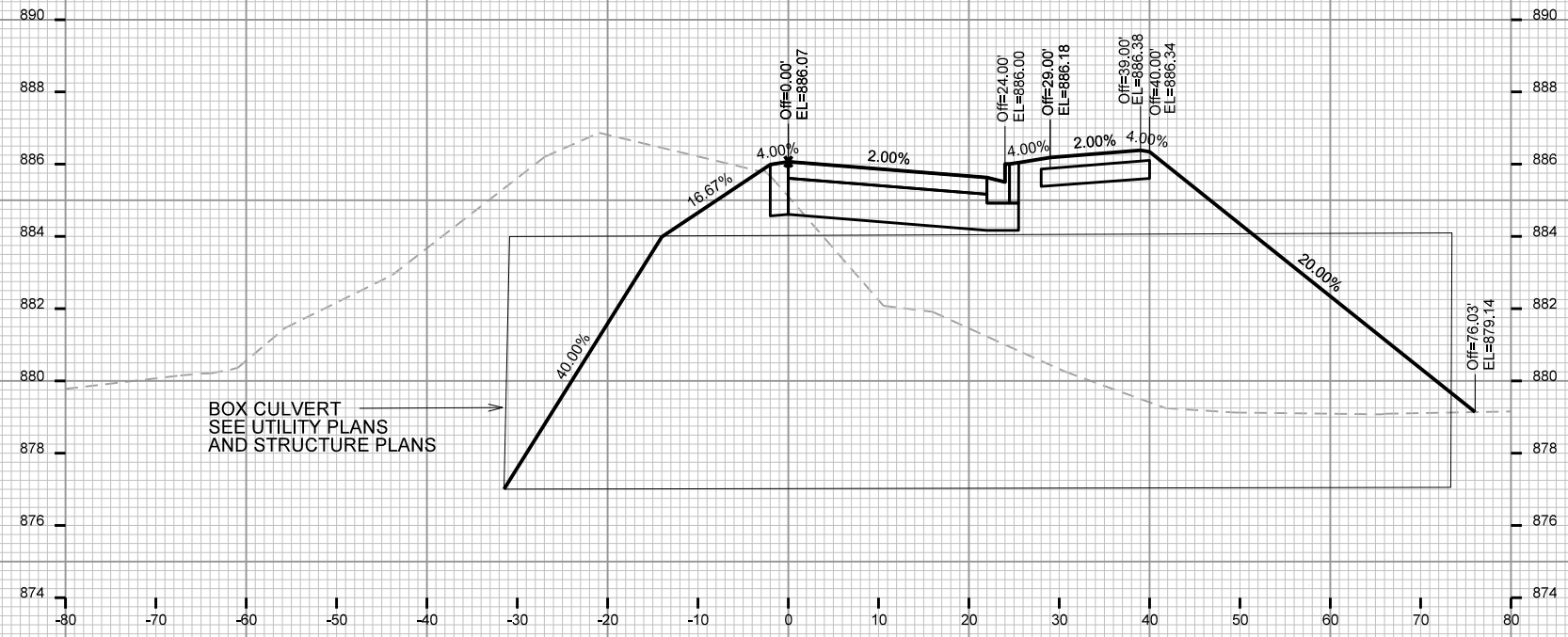

STA. 26+50

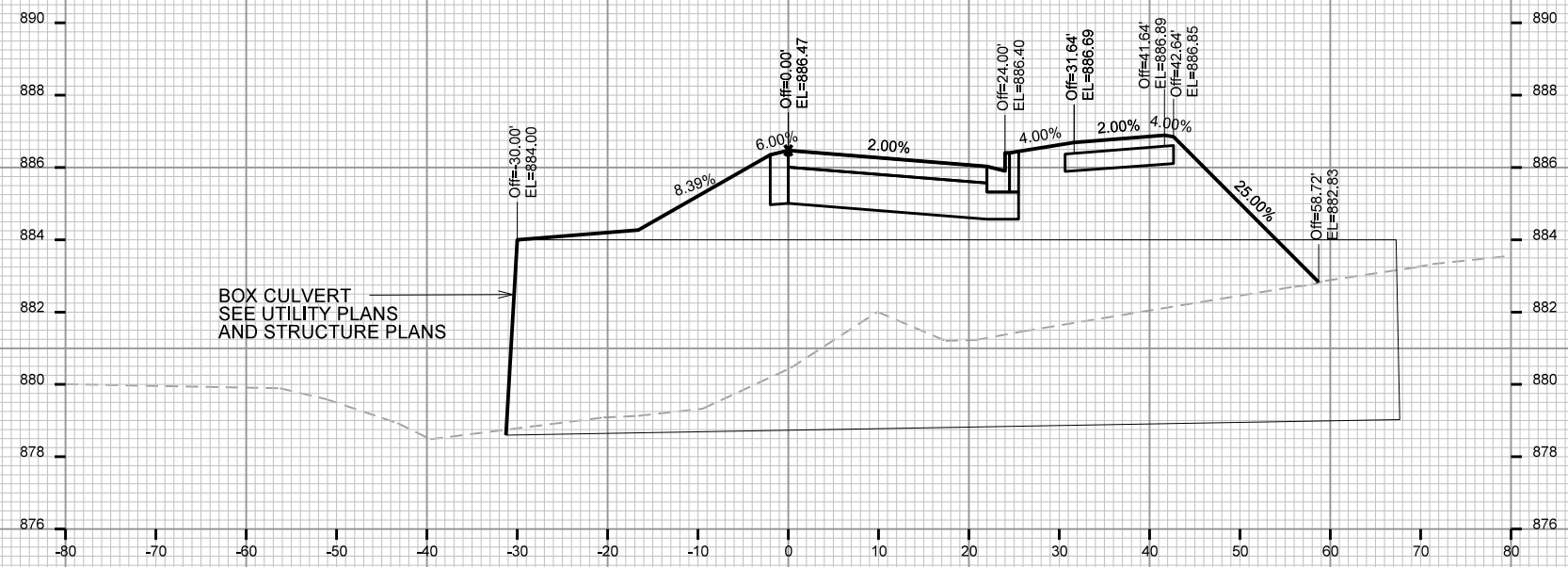

STA. 26+25

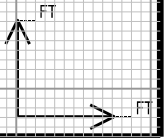

PLOT SCALE: _____

PLOT NAME: _____

REV. DATE: _____

ORIGINATOR: CITY OF MADISON, STREETS DIVISION

CROSS SECTIONS
CITY VIEW DRIVE CITY OF MADISON

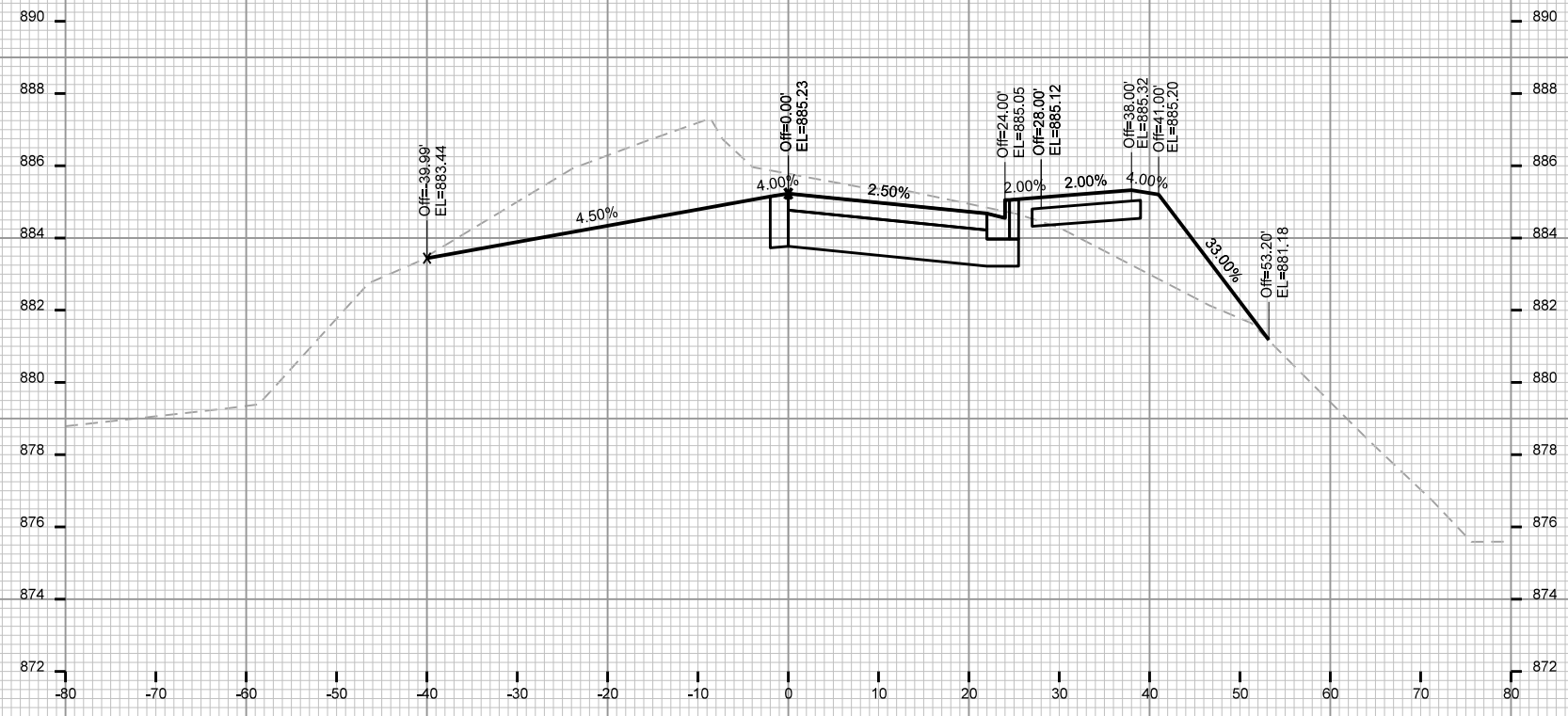

STA. 27+00

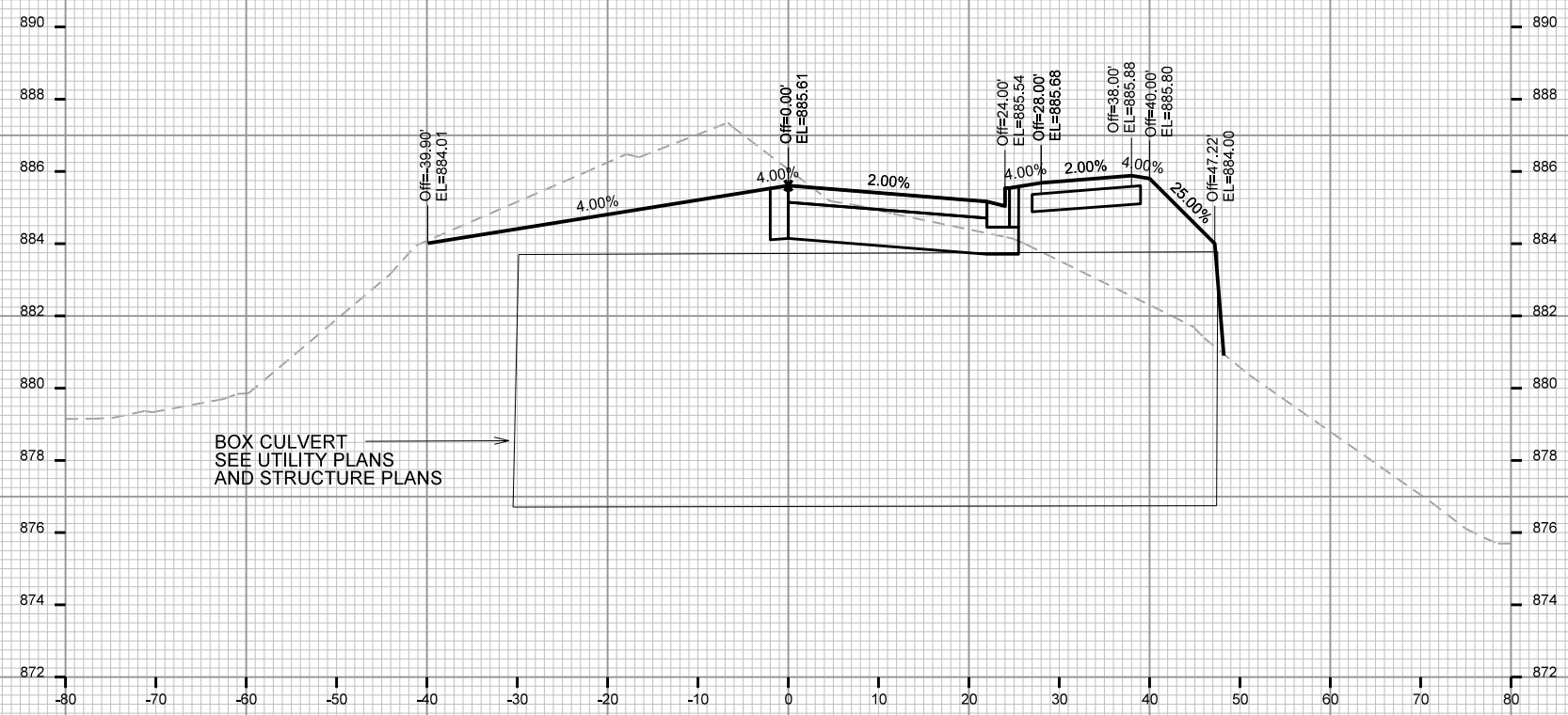

STA. 26+75



PLOT SCALE: _____

PLOT NAME: _____

REV. DATE: _____

ORIGINATOR: CITY OF MADISON, STREETS DIVISION

CROSS SECTIONS

CITY VIEW DRIVE

CITY OF MADISON

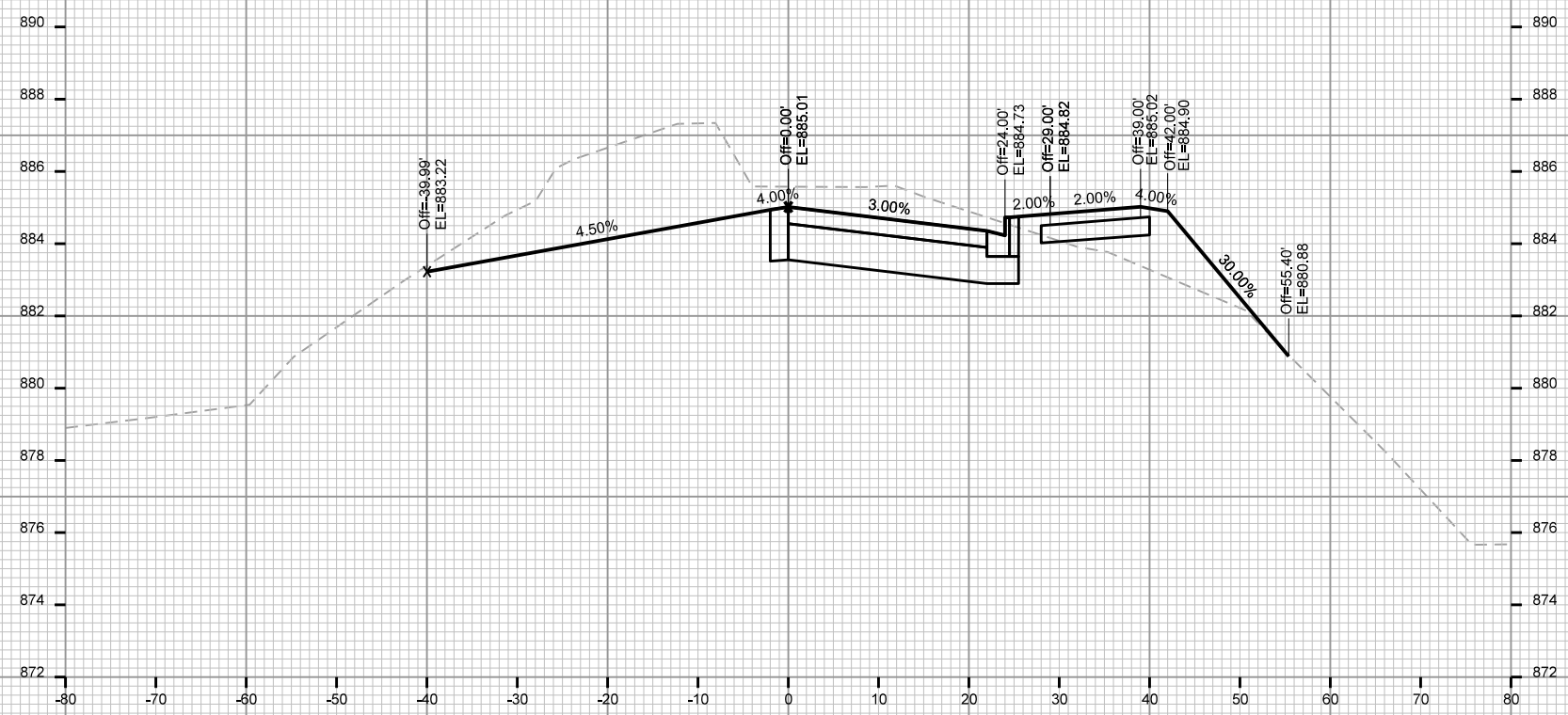

PLOT SCALE: _____

PLOT NAME: _____

REV. DATE: _____

ORIGINATOR: CITY OF MADISON, STREETS DIVISION

CROSS SECTIONS

CITY VIEW DRIVE

CITY OF MADISON

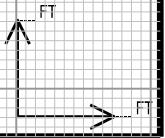
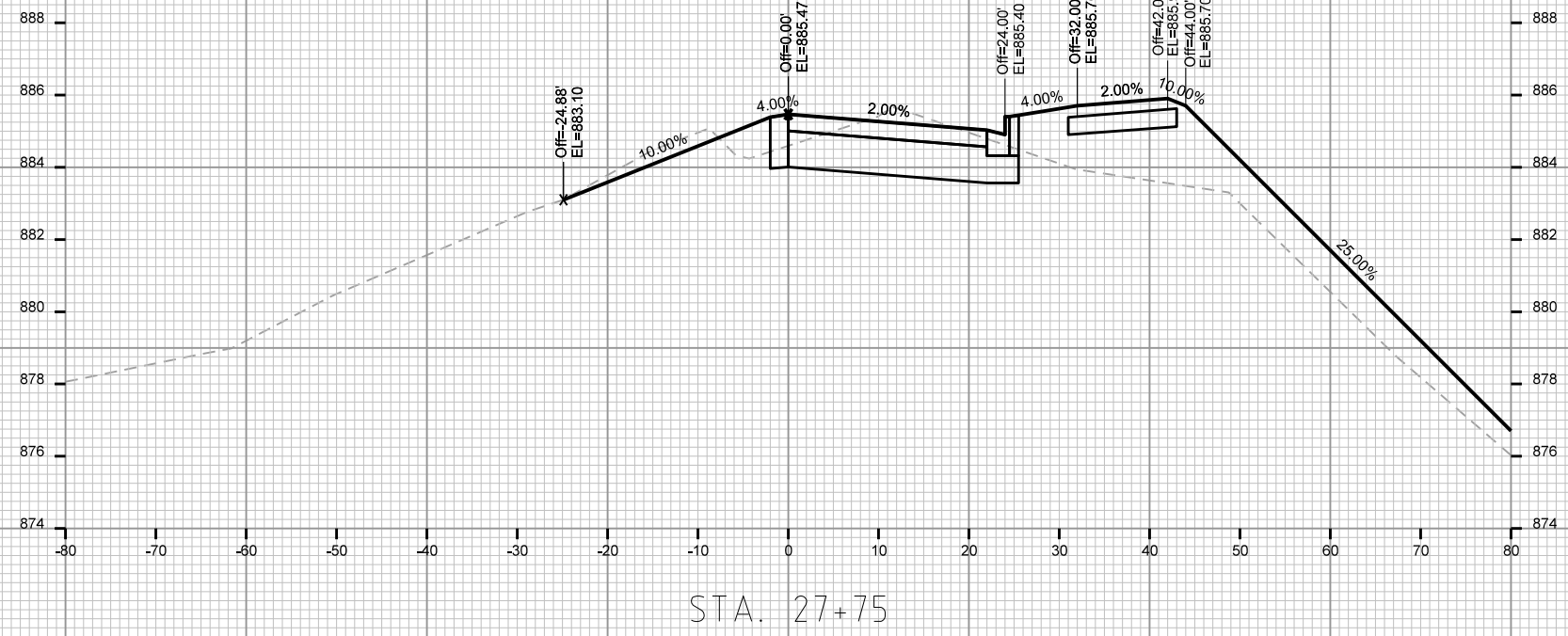
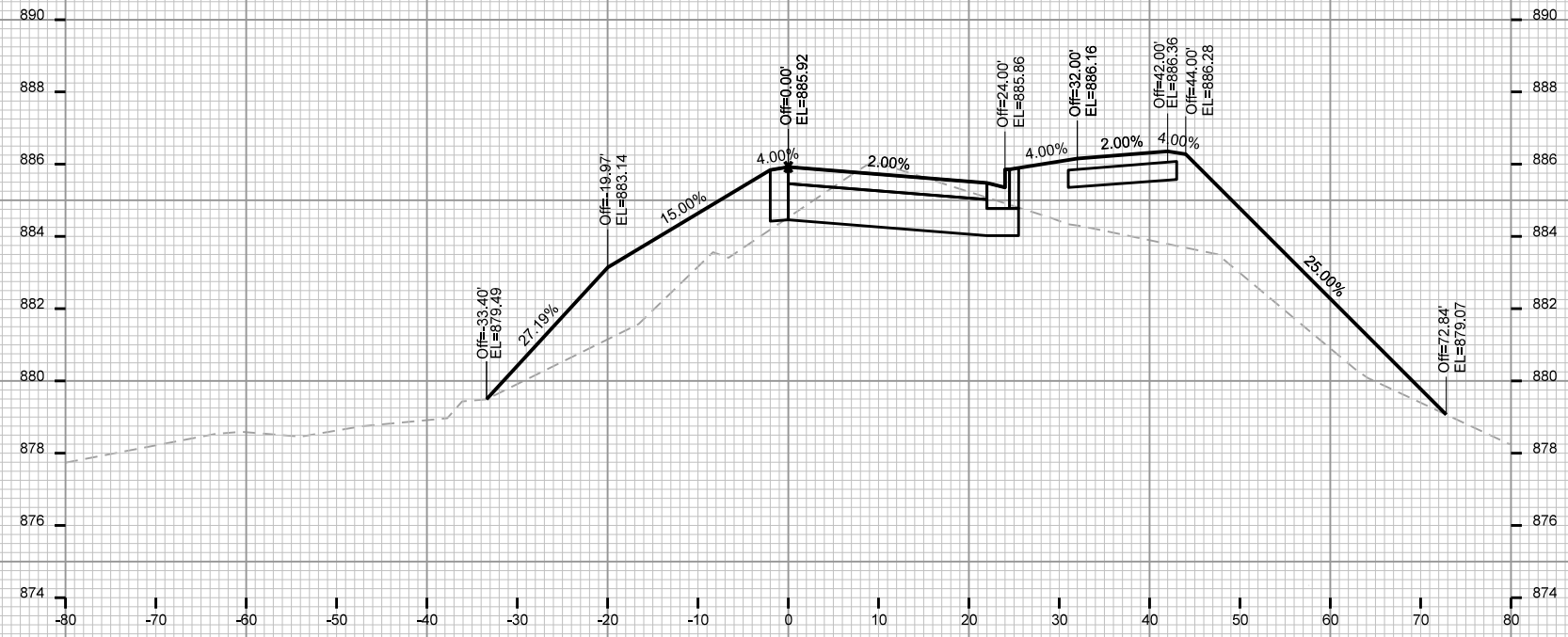

PLOT SCALE: _____

PLOT NAME: _____

REV. DATE: _____

ORIGINATOR: CITY OF MADISON, STREETS DIVISION

CROSS SECTIONS

CITY VIEW DRIVE

CITY OF MADISON

PLOT SCALE: _____

PLOT NAME: _____

REV. DATE: _____

ORIGINATOR: CITY OF MADISON, STREETS DIVISION

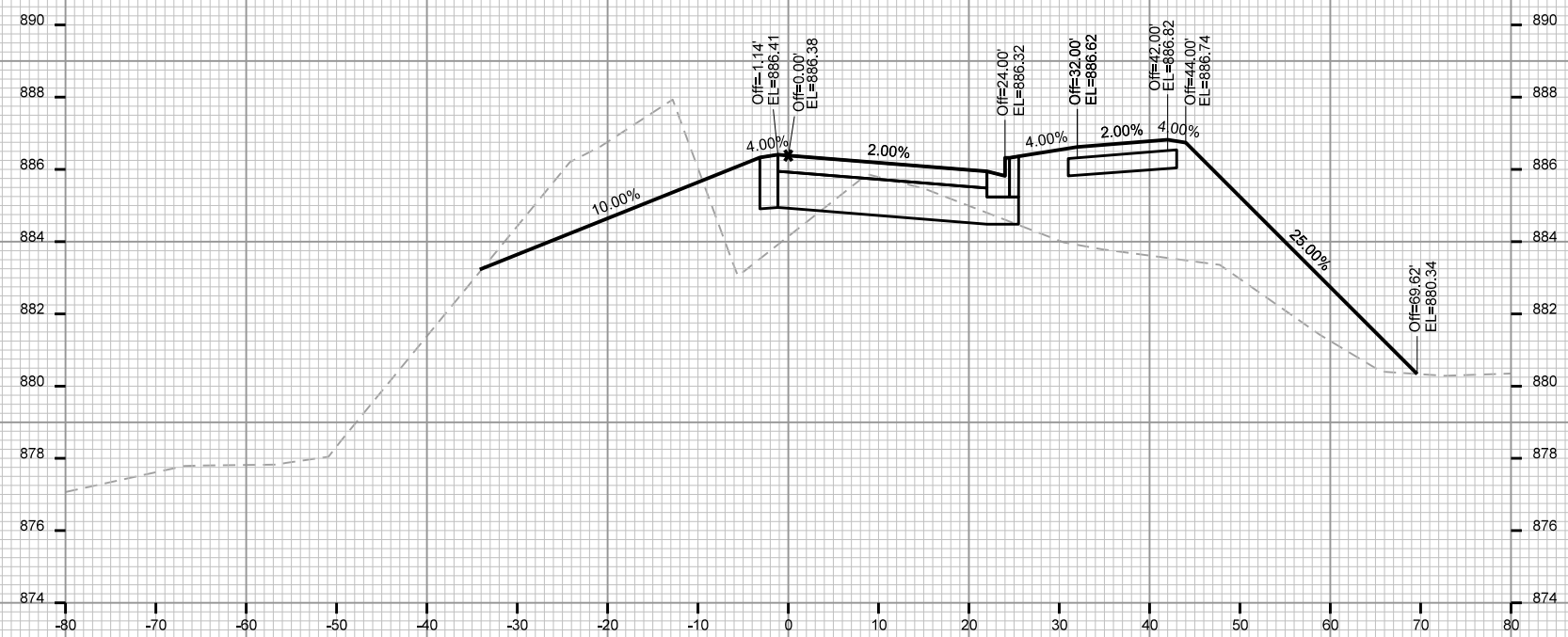
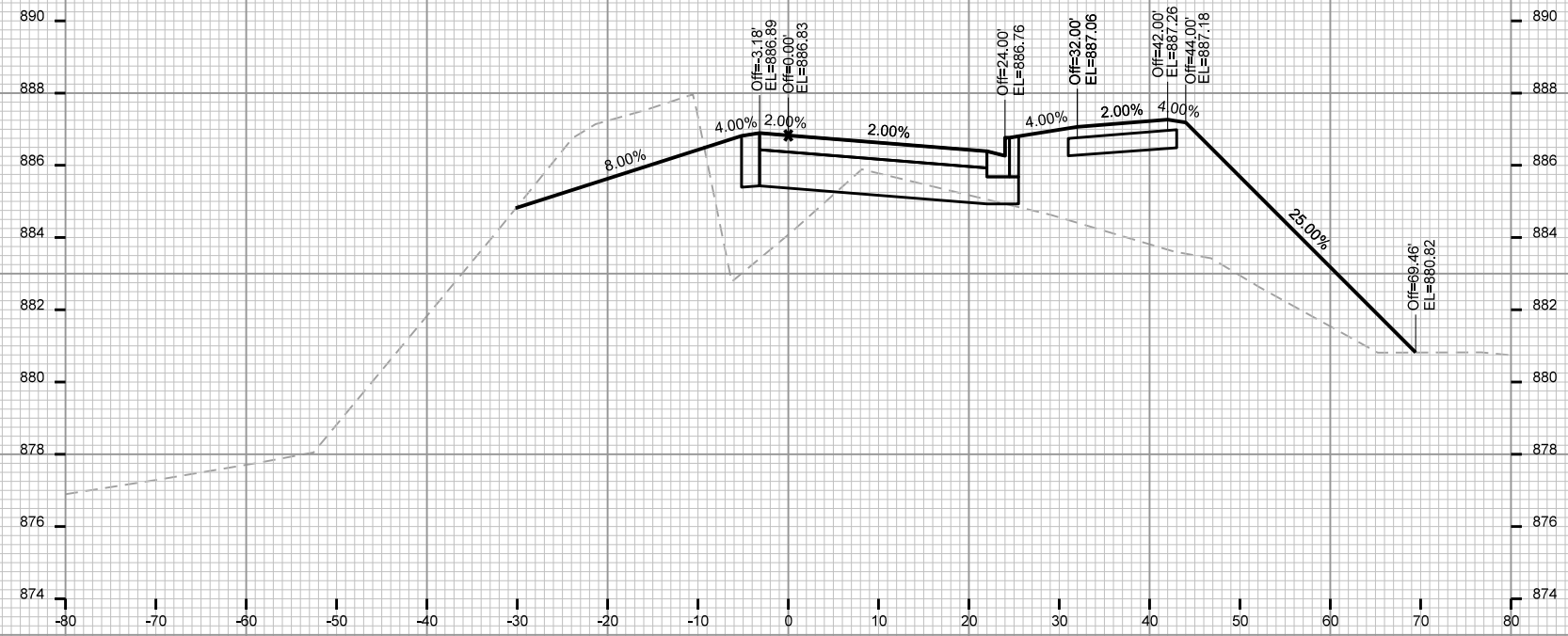

CROSS SECTIONS

CITY VIEW DRIVE

CITY OF MADISON

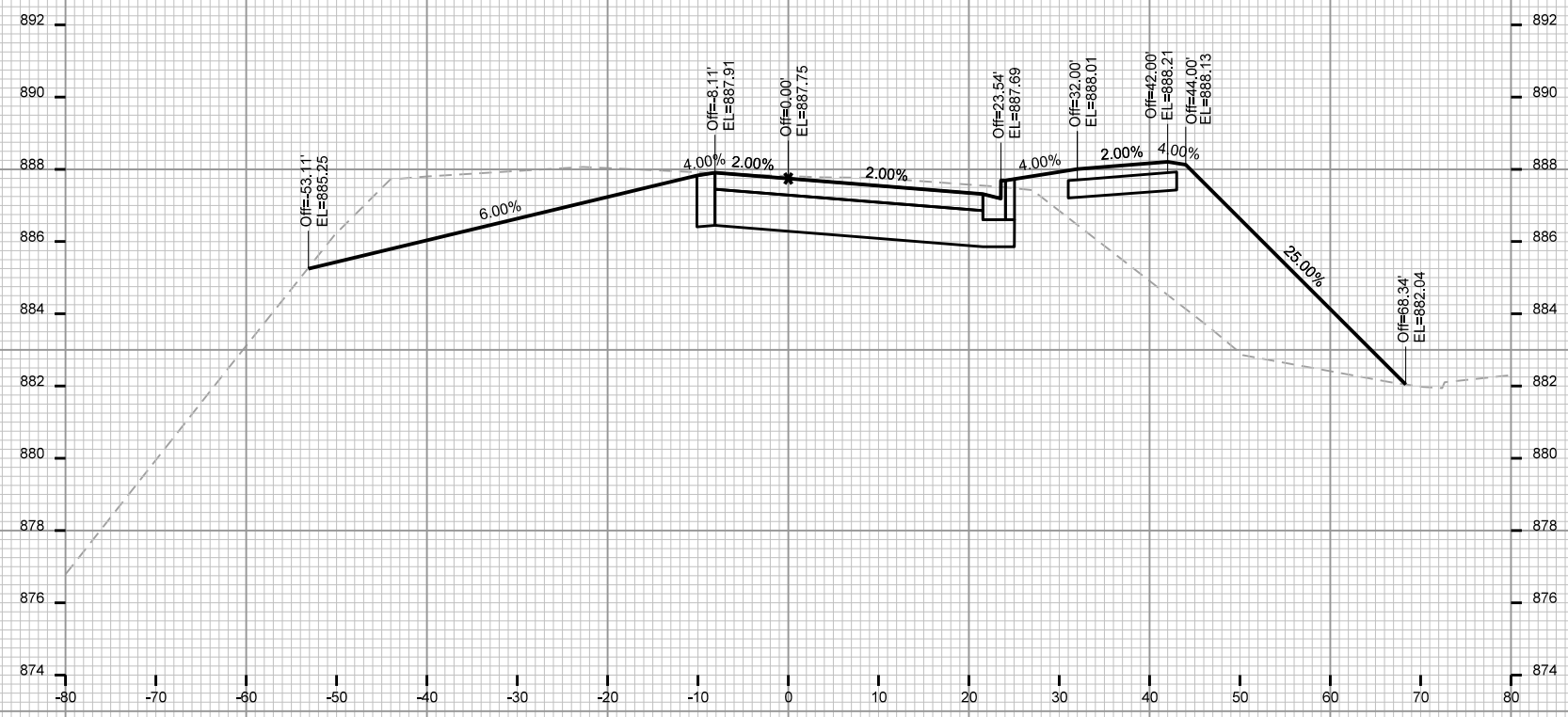

STA. 29+00



STA. 28+75



PLOT SCALE: _____

PLOT NAME: _____

REV. DATE: _____

ORIGINATOR: CITY OF MADISON, STREETS DIVISION

CROSS SECTIONS

CITY VIEW DRIVE

CITY OF MADISON

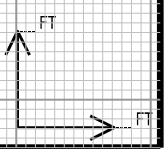
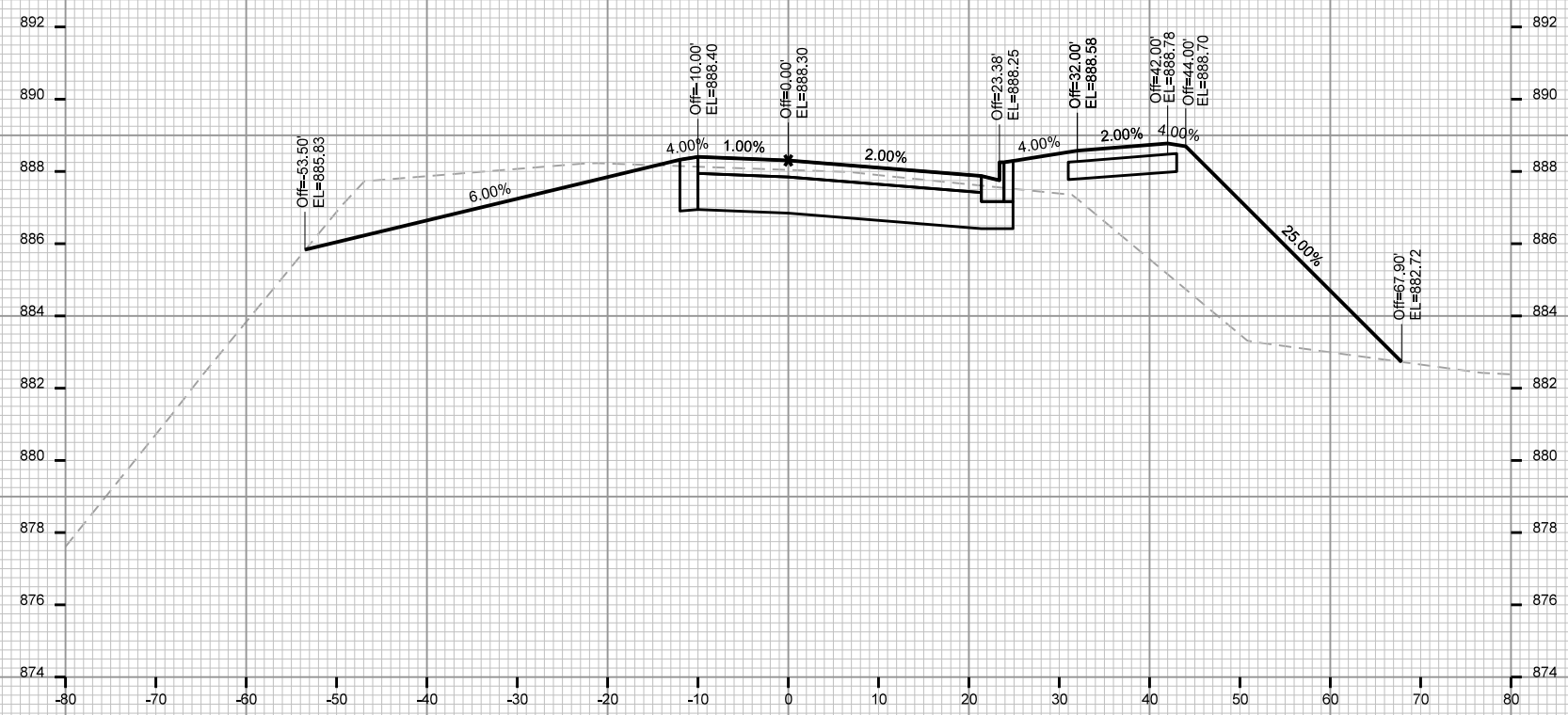

PLOT SCALE: _____

PLOT NAME: _____

REV. DATE: _____

ORIGINATOR: CITY OF MADISON, STREETS DIVISION

CROSS SECTIONS

CITY VIEW DRIVE

CITY OF MADISON

PLOT SCALE: _____

PLOT NAME: _____

REV. DATE: _____

ORIGINATOR: CITY OF MADISON, STREETS DIVISION

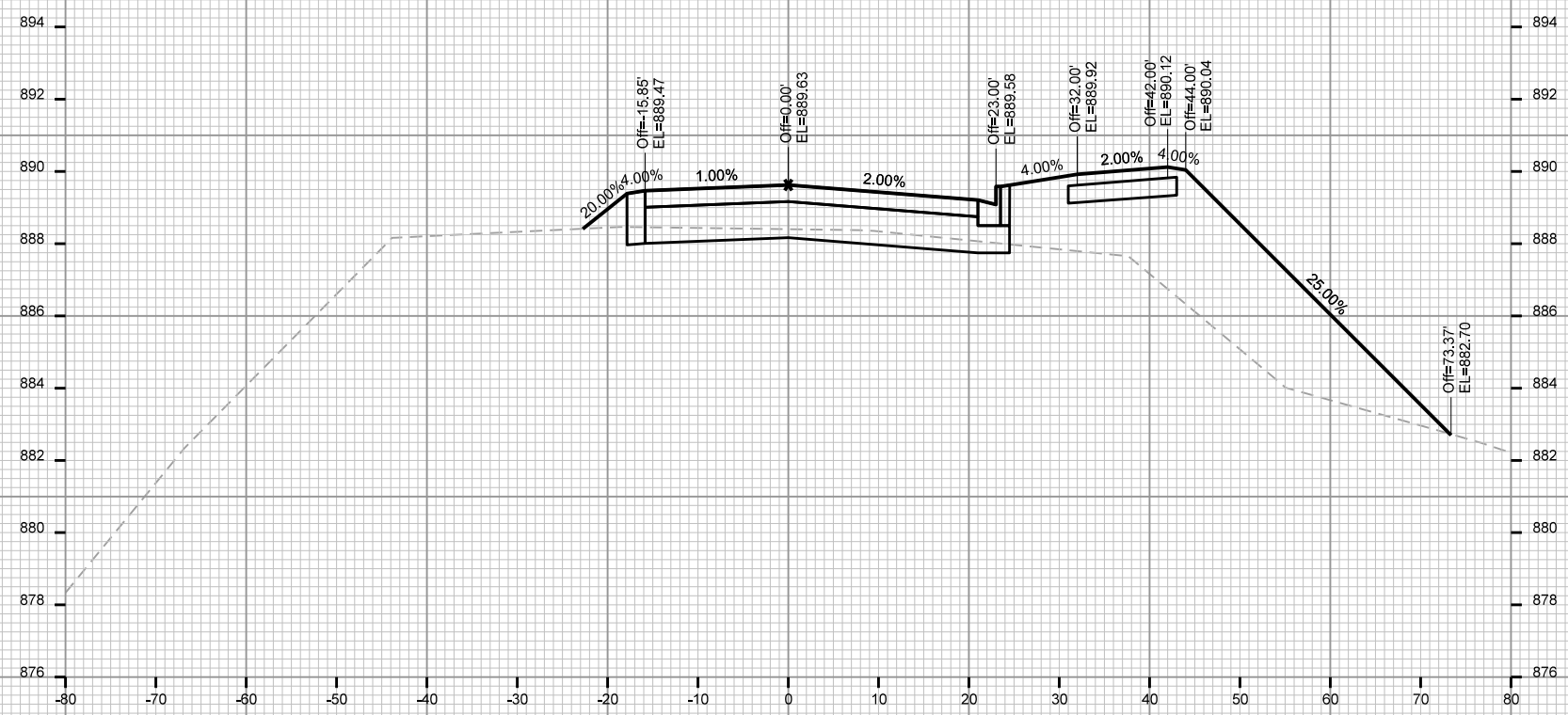
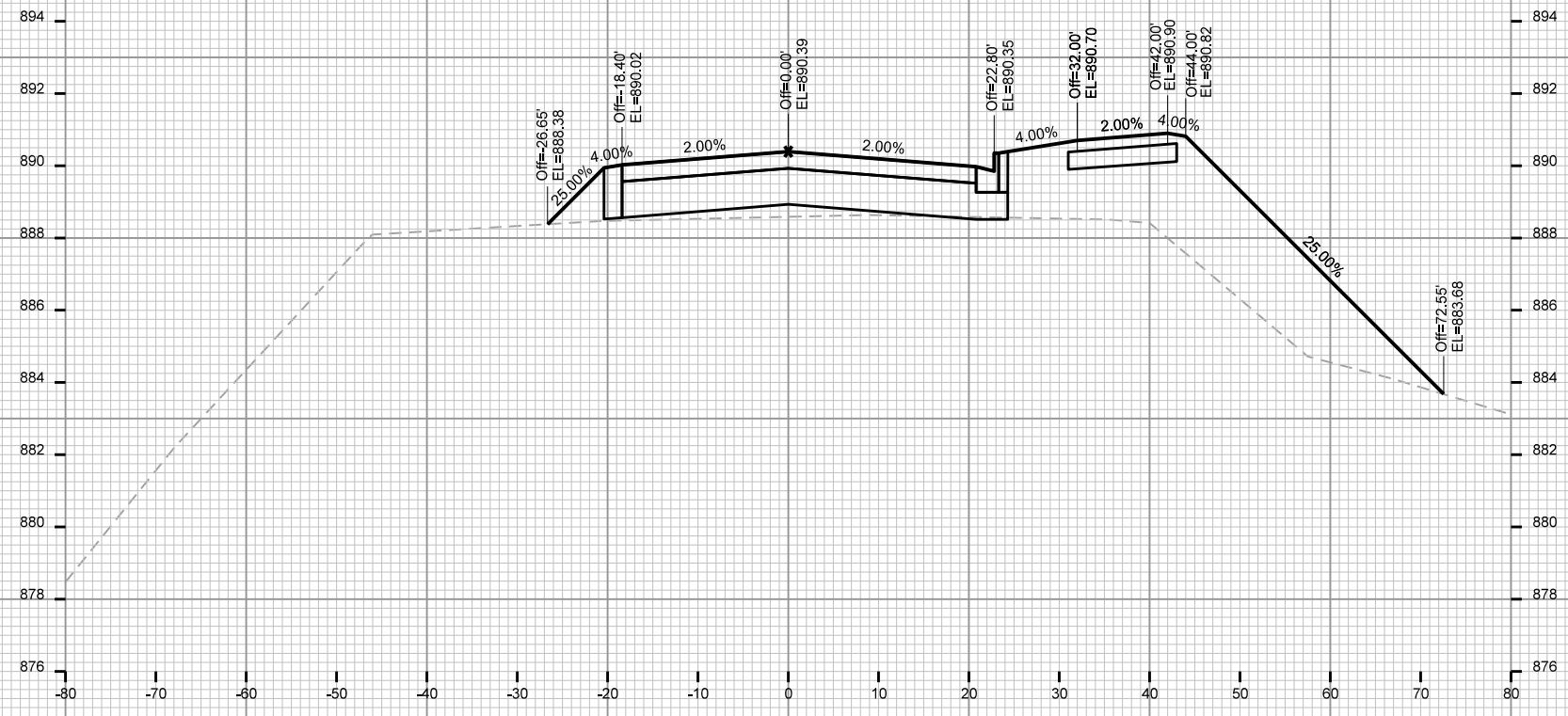

CROSS SECTIONS

CITY VIEW DRIVE

CITY OF MADISON

PLOT SCALE: _____

PLOT NAME: _____

REV. DATE: _____

ORIGINATOR: CITY OF MADISON, STREETS DIVISION

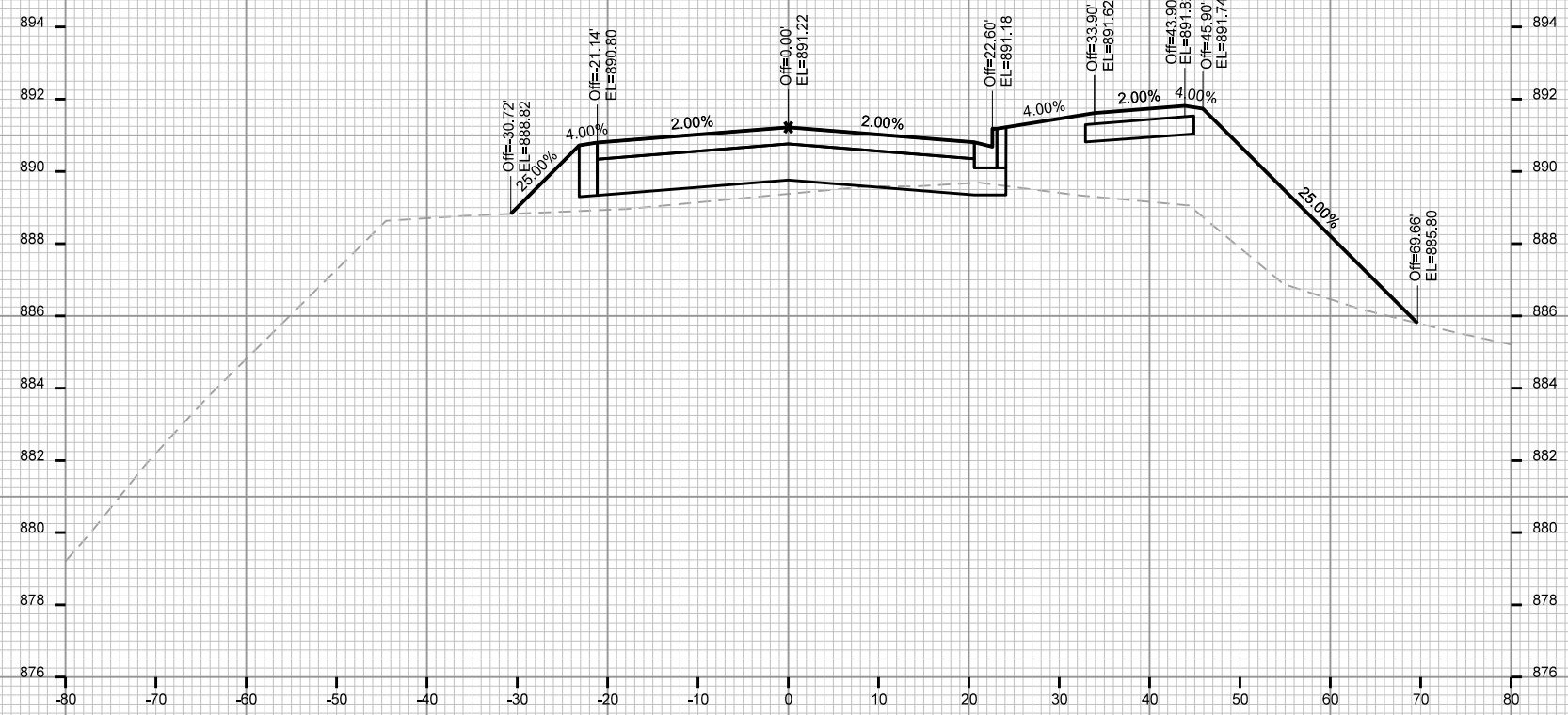

STA. 30+25



CROSS SECTIONS

CITY VIEW DRIVE

CITY OF MADISON

PLOT SCALE: _____

PLOT NAME: _____

REV. DATE: _____

ORIGINATOR: CITY OF MADISON, STREETS DIVISION

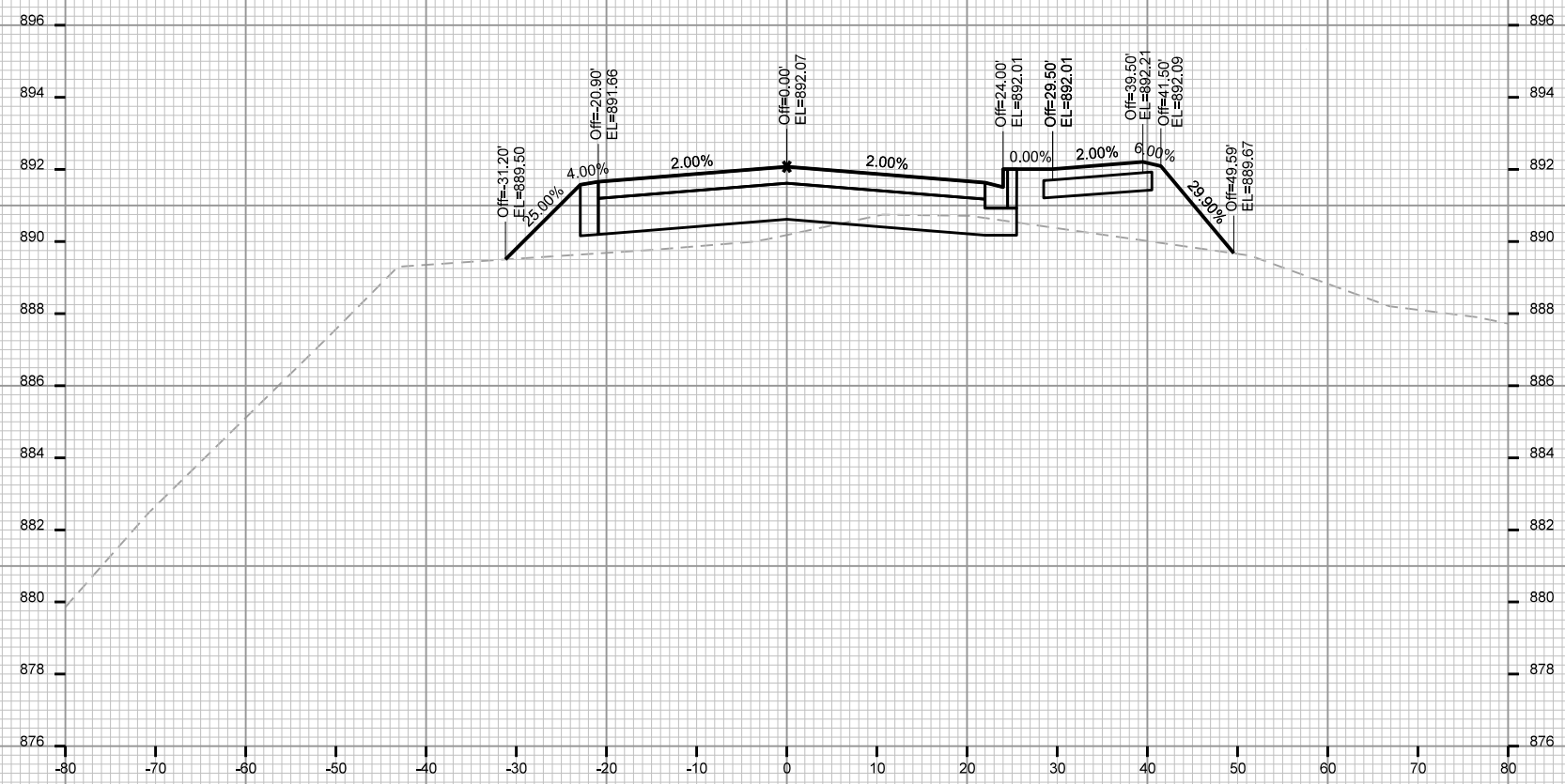

STA. 30+50



CROSS SECTIONS

CITY VIEW DRIVE

CITY OF MADISON

PLOT SCALE: _____

PLOT NAME: _____

REV. DATE: _____

ORIGINATOR: CITY OF MADISON, STREETS DIVISION

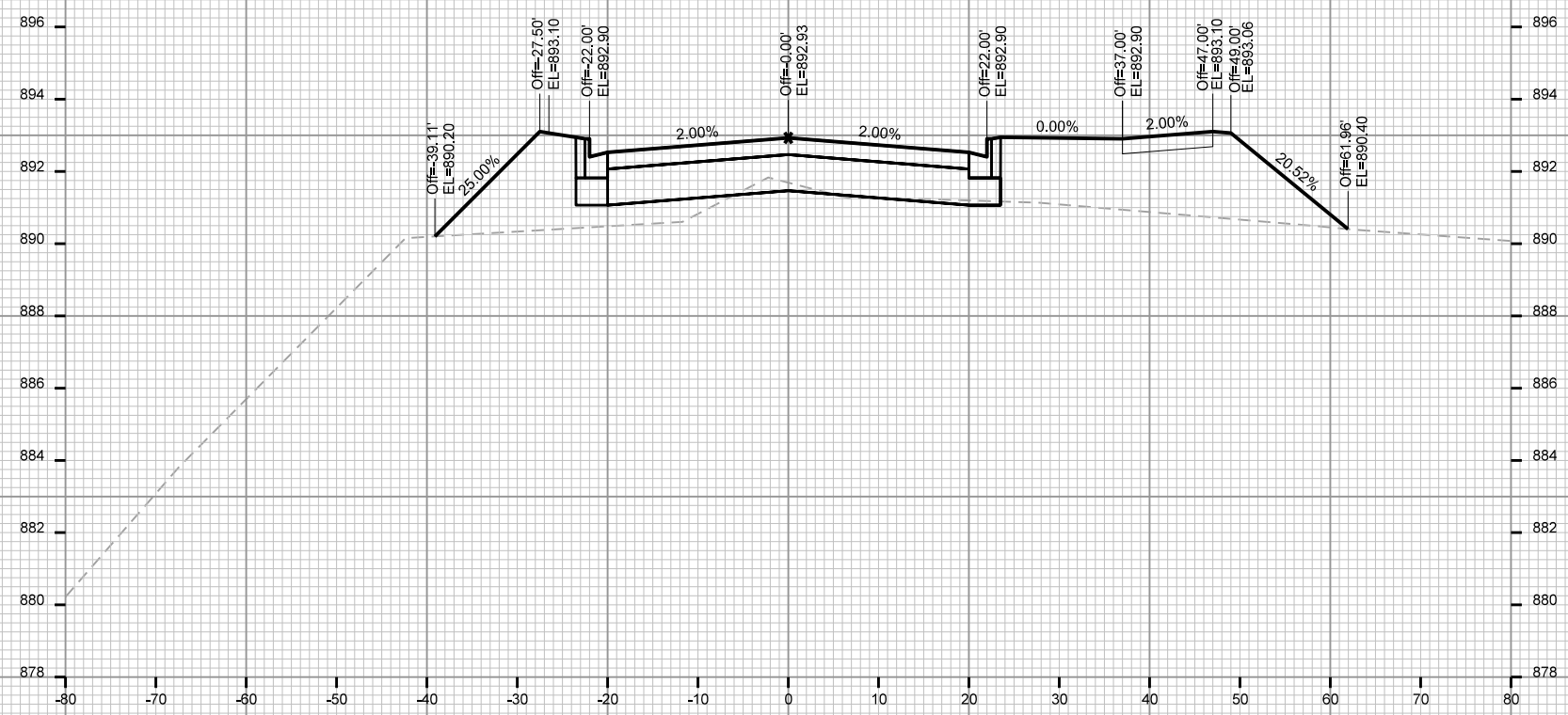

CROSS SECTIONS

CITY VIEW DRIVE

CITY OF MADISON

PLOT SCALE: _____

PLOT NAME: _____

REV. DATE: _____

ORIGINATOR: CITY OF MADISON, STREETS DIVISION

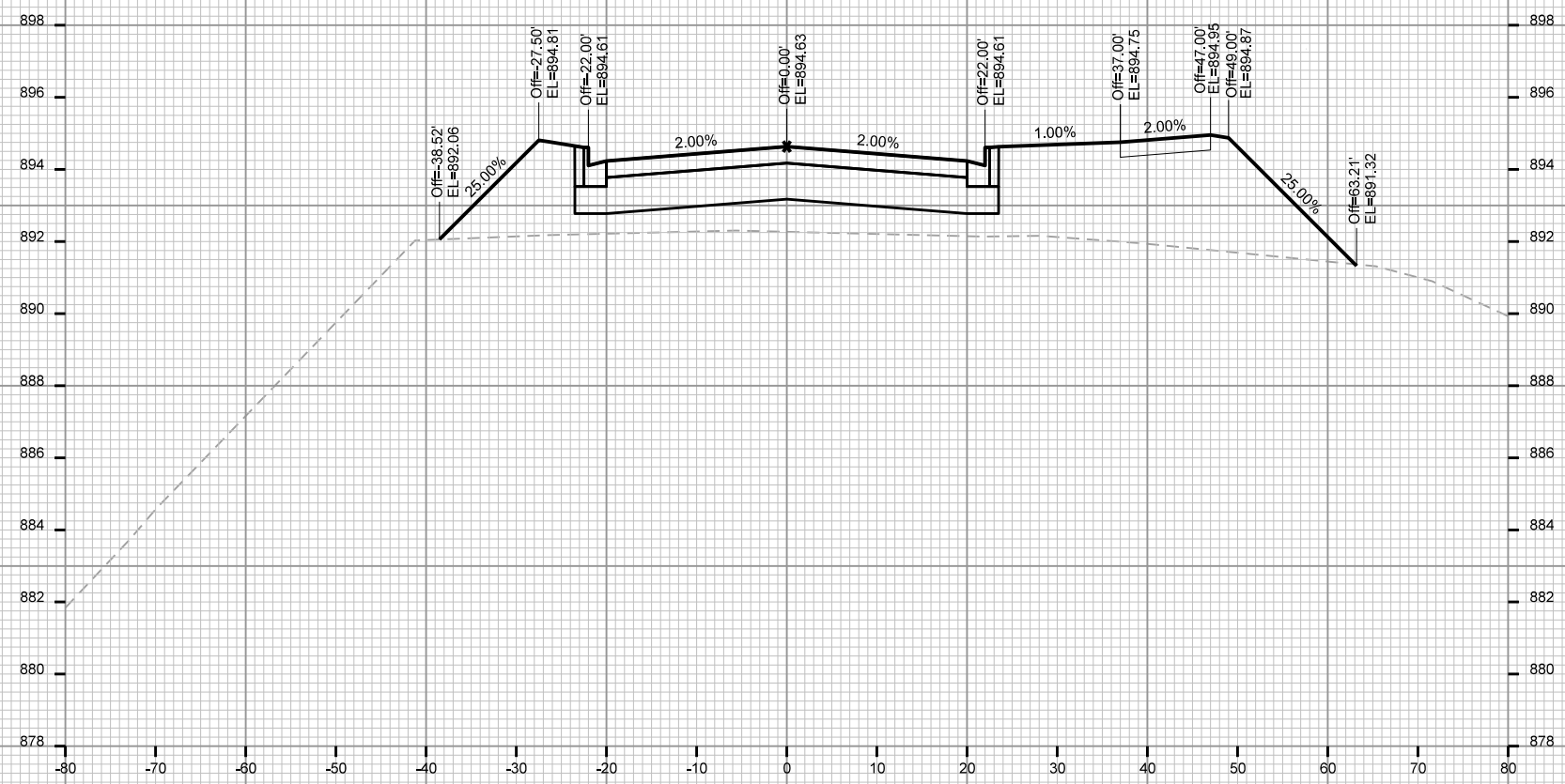

STA. 31+25



CROSS SECTIONS

CITY VIEW DRIVE

CITY OF MADISON

PLOT SCALE: _____

PLOT NAME: _____

REV. DATE: _____

ORIGINATOR: CITY OF MADISON, STREETS DIVISION

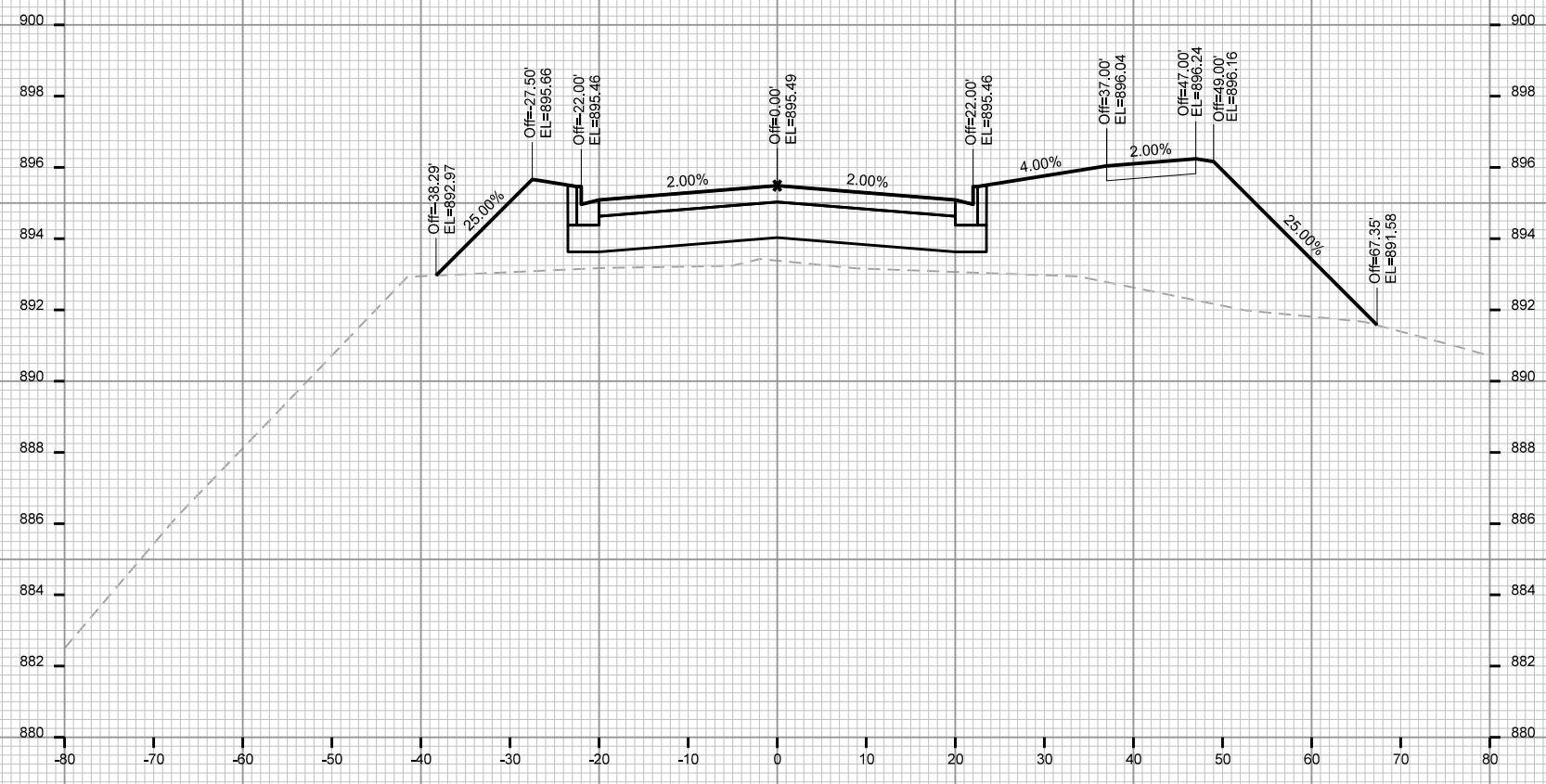

STA. 31+50



CROSS SECTIONS

CITY VIEW DRIVE

CITY OF MADISON

PLOT SCALE: _____

PLOT NAME: _____

REV. DATE: _____

ORIGINATOR: CITY OF MADISON, STREETS DIVISION

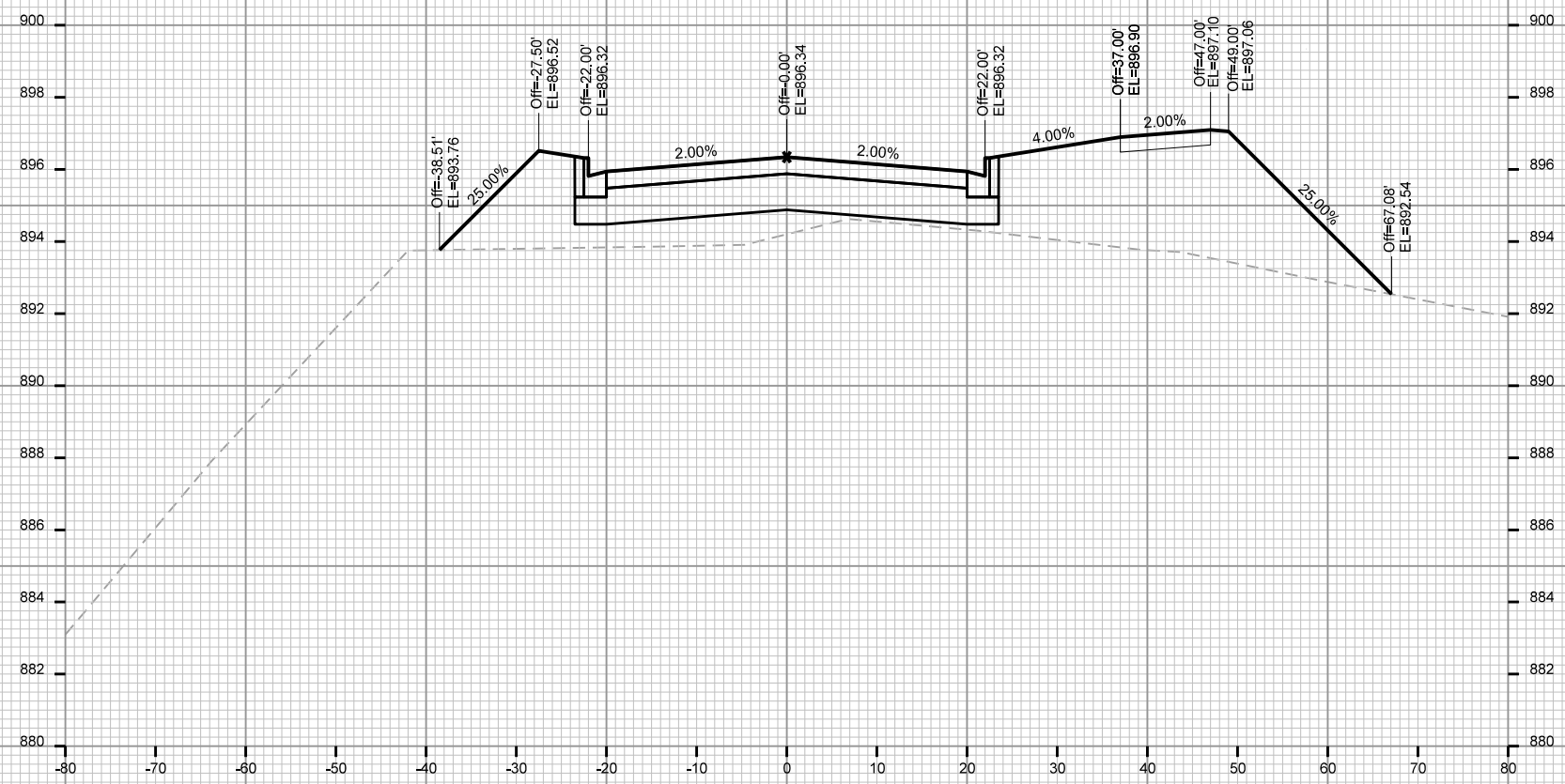

STA. 31+75



CROSS SECTIONS

CITY VIEW DRIVE

CITY OF MADISON

PLOT SCALE: _____

PLOT NAME: _____

REV. DATE: _____

ORIGINATOR: CITY OF MADISON, STREETS DIVISION

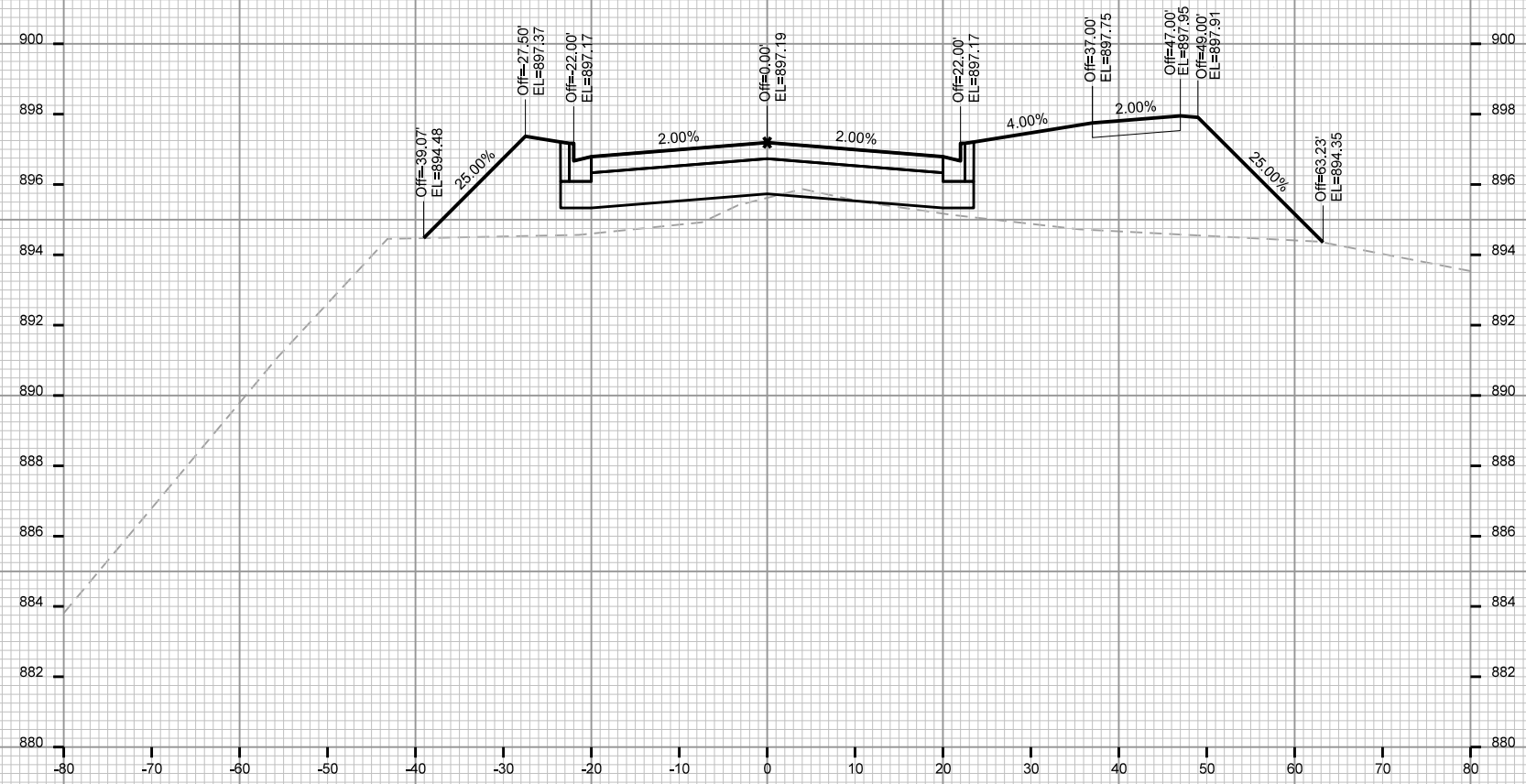

STA. 32+00



CROSS SECTIONS

CITY VIEW DRIVE

CITY OF MADISON

PLOT SCALE: _____

PLOT NAME: _____

REV. DATE: _____

ORIGINATOR: CITY OF MADISON, STREETS DIVISION

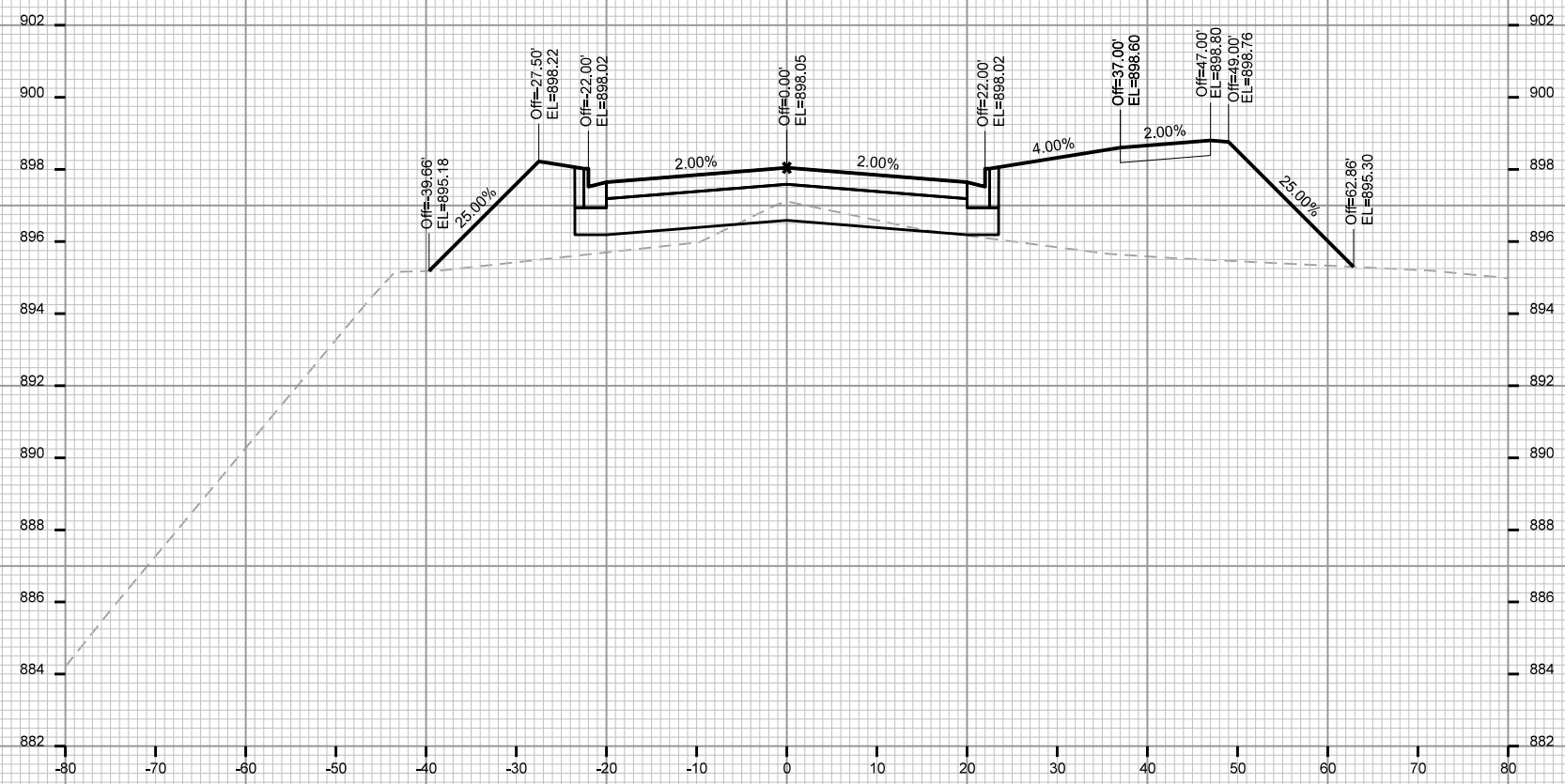

STA. 32+25



CROSS SECTIONS

CITY VIEW DRIVE

CITY OF MADISON

PLOT SCALE: _____

PLOT NAME: _____

REV. DATE: _____

ORIGINATOR: CITY OF MADISON, STREETS DIVISION

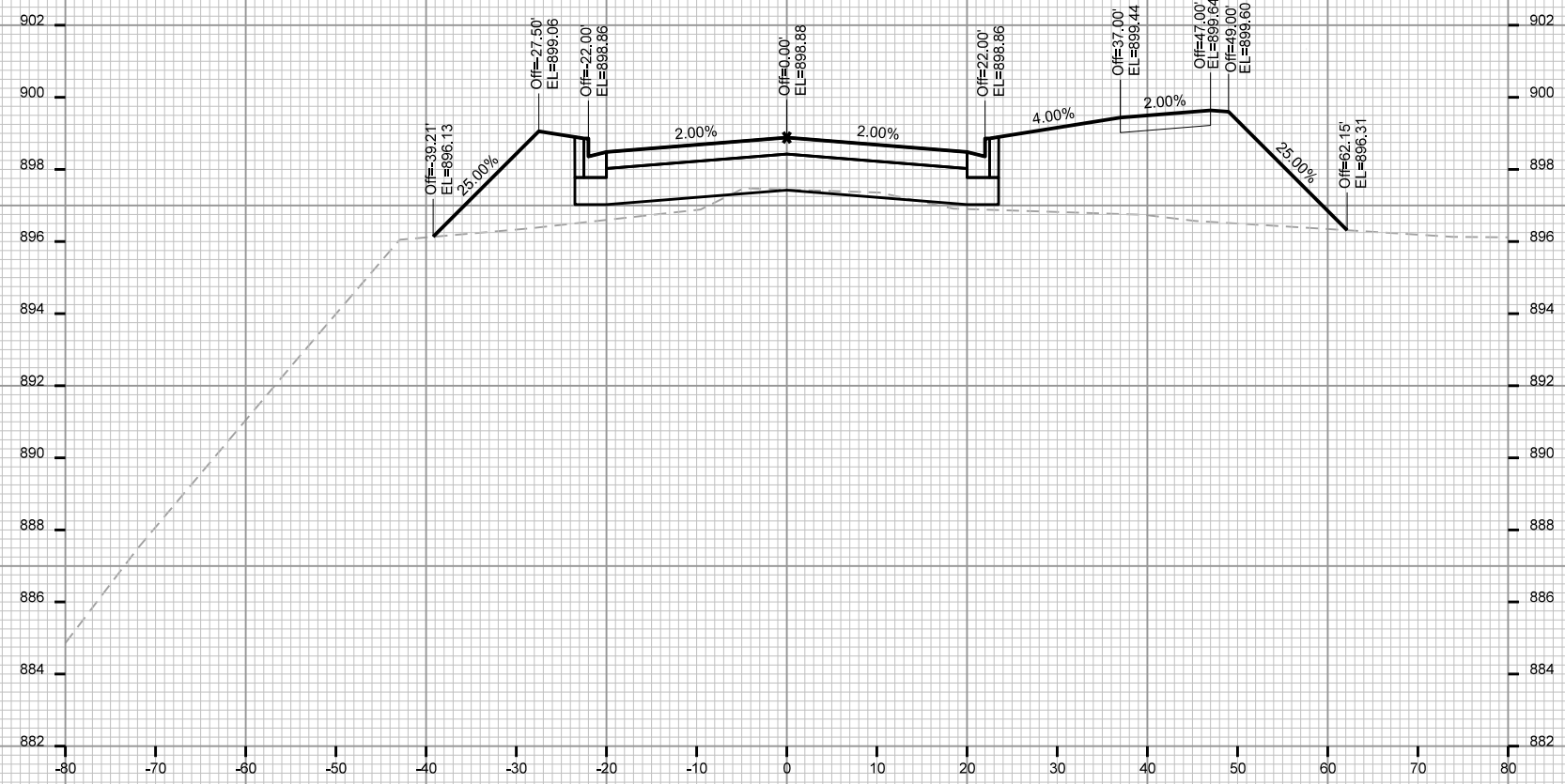

STA. 32+50



CROSS SECTIONS

CITY VIEW DRIVE

CITY OF MADISON

PLOT SCALE: _____

PLOT NAME: _____

REV. DATE: _____

ORIGINATOR: CITY OF MADISON, STREETS DIVISION

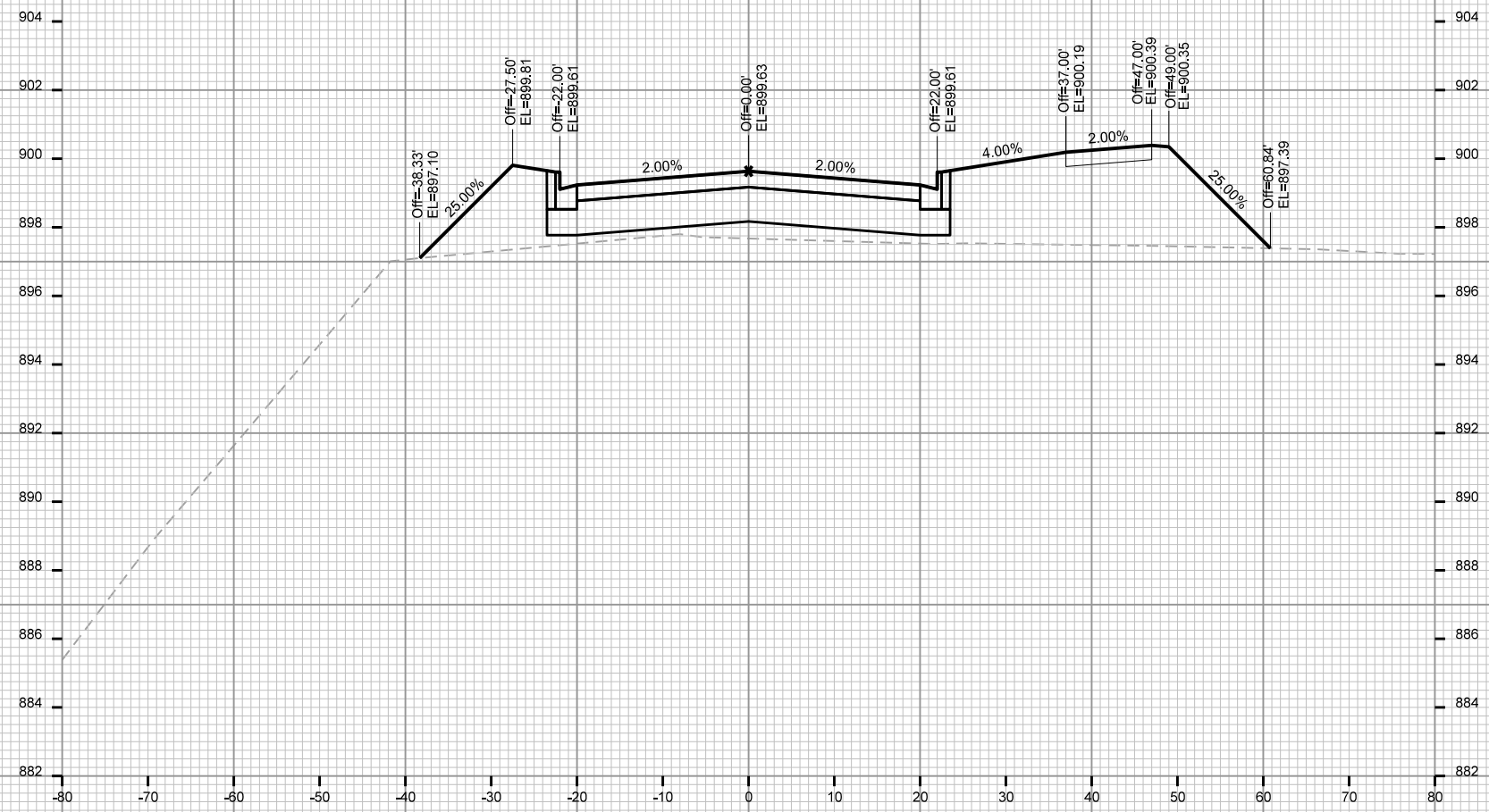

CROSS SECTIONS

CITY VIEW DRIVE

CITY OF MADISON

PLOT SCALE: _____

PLOT NAME: _____

REV. DATE: _____

ORIGINATOR: CITY OF MADISON, STREETS DIVISION

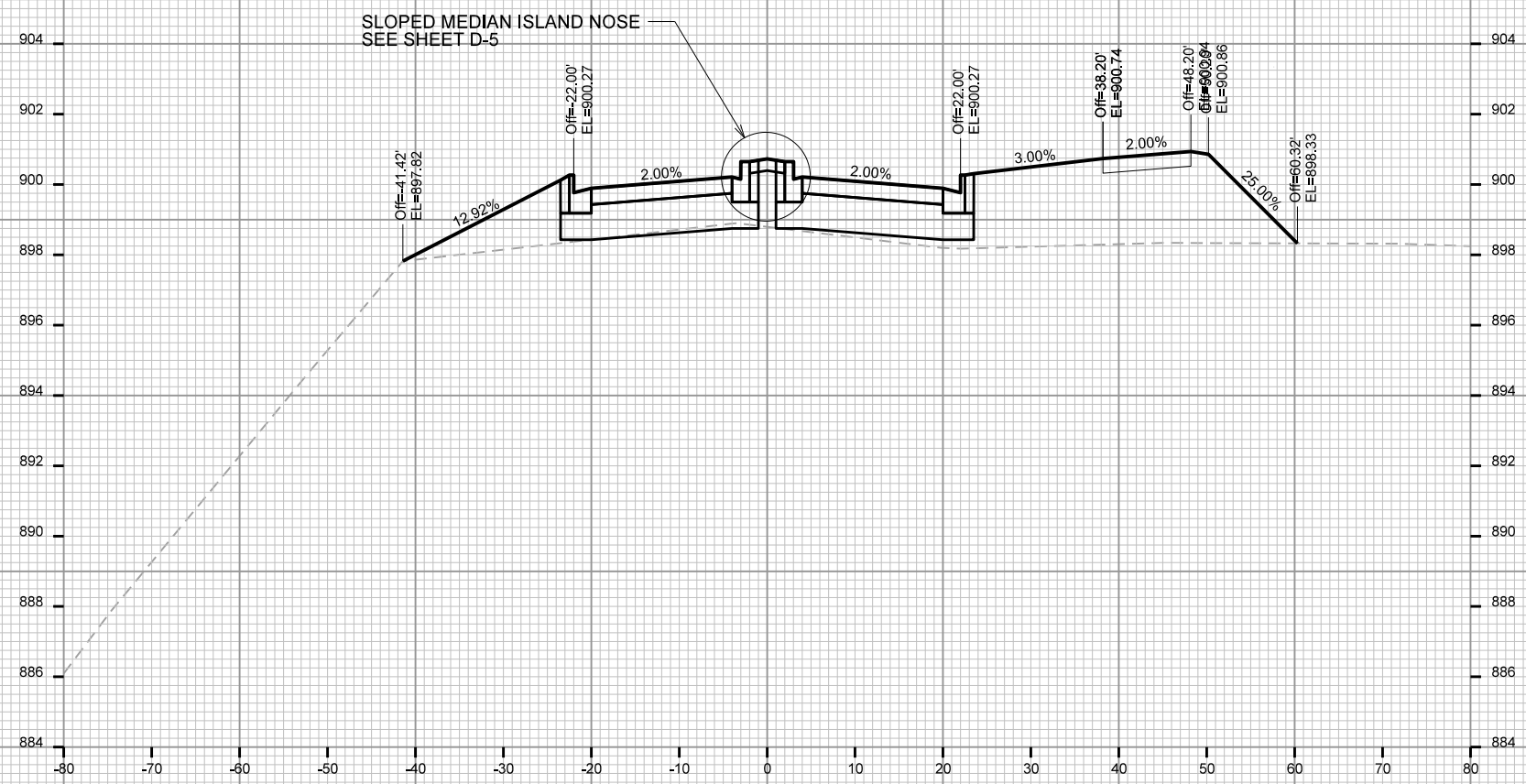

STA. 33+00



CROSS SECTIONS

CITY VIEW DRIVE

CITY OF MADISON

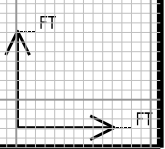
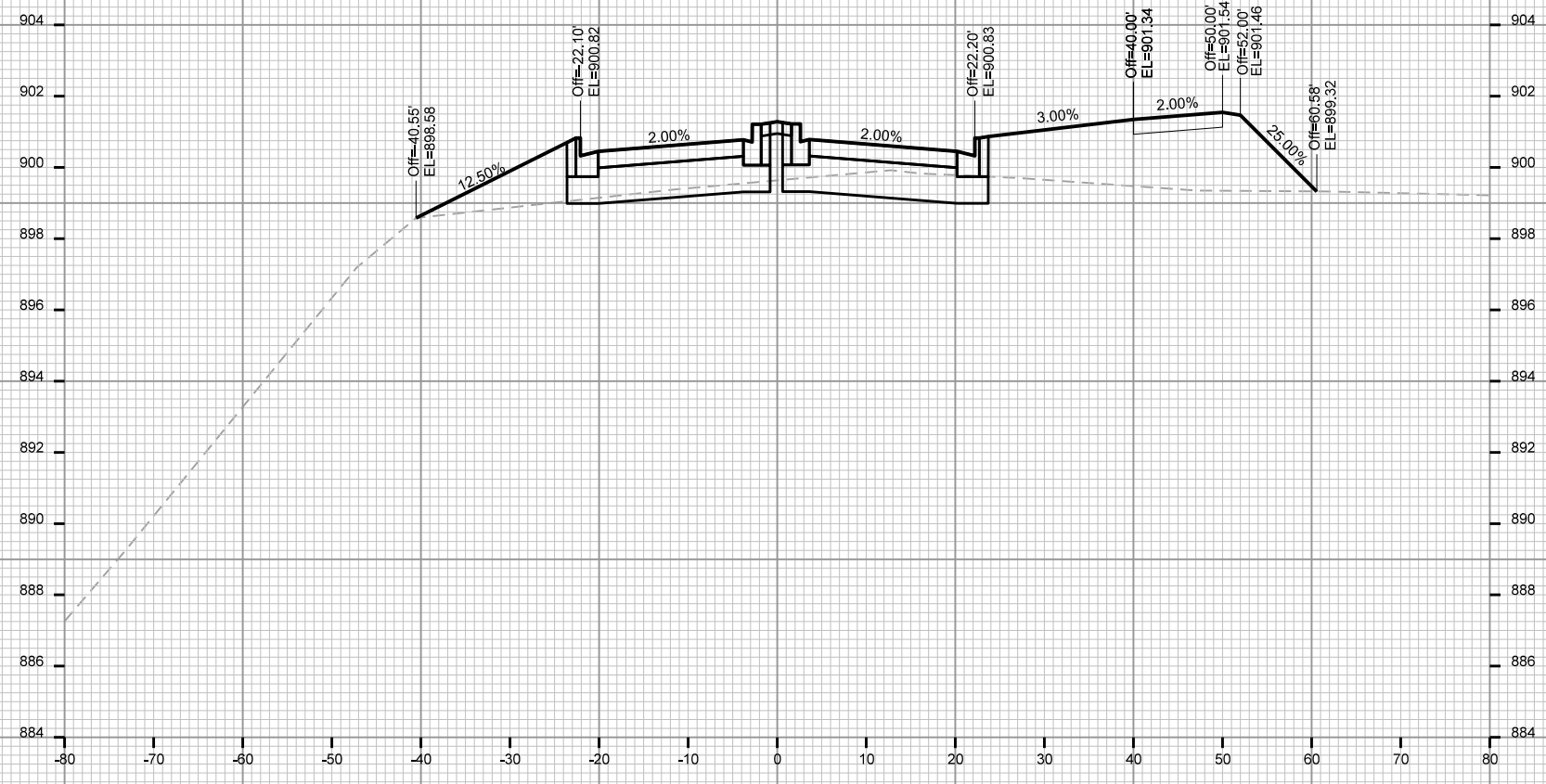
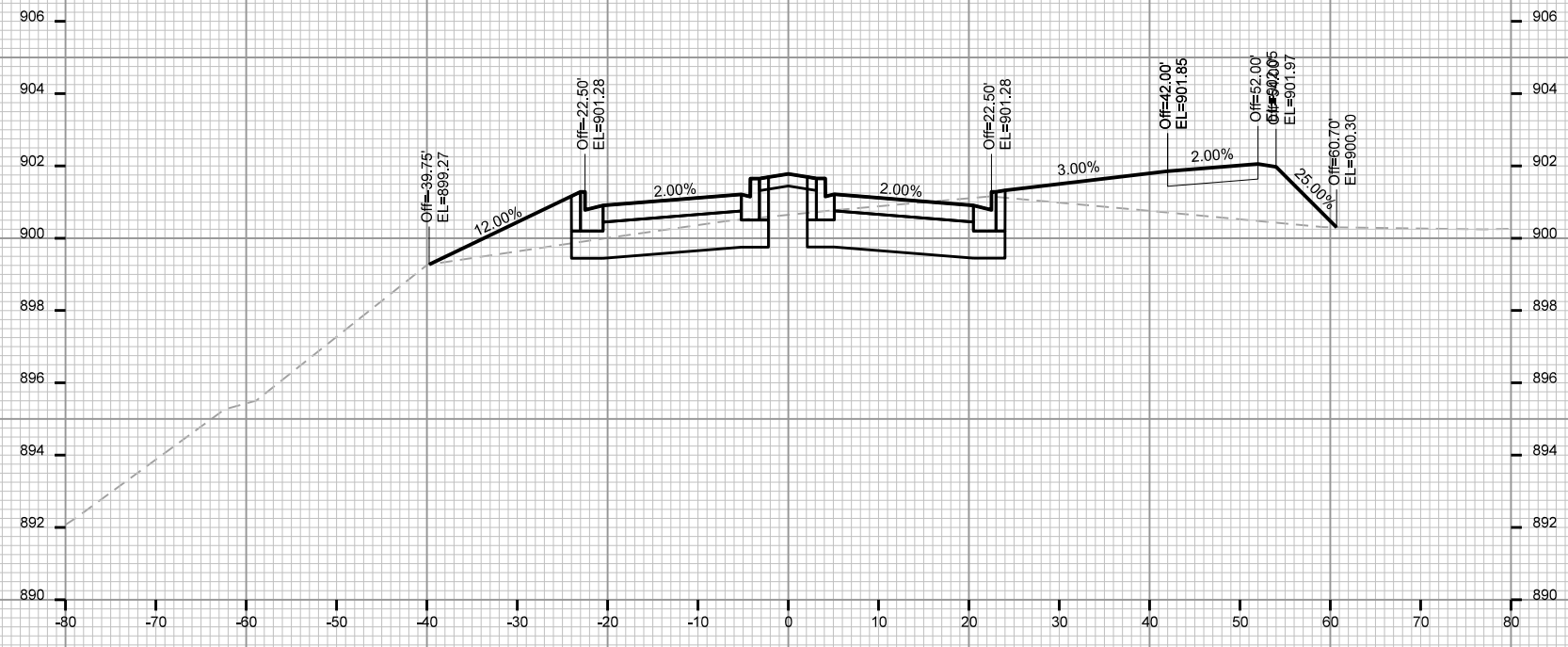

PLOT SCALE: _____

PLOT NAME: _____

REV. DATE: _____

ORIGINATOR: CITY OF MADISON, STREETS DIVISION

CROSS SECTIONS

CITY VIEW DRIVE

CITY OF MADISON

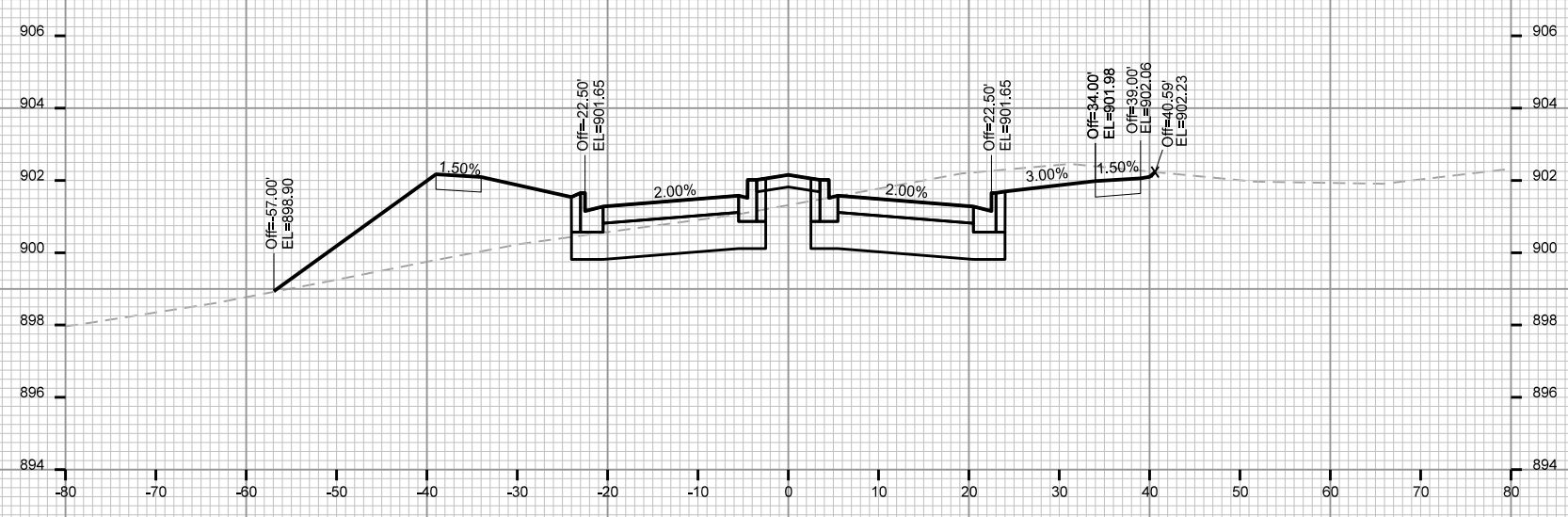
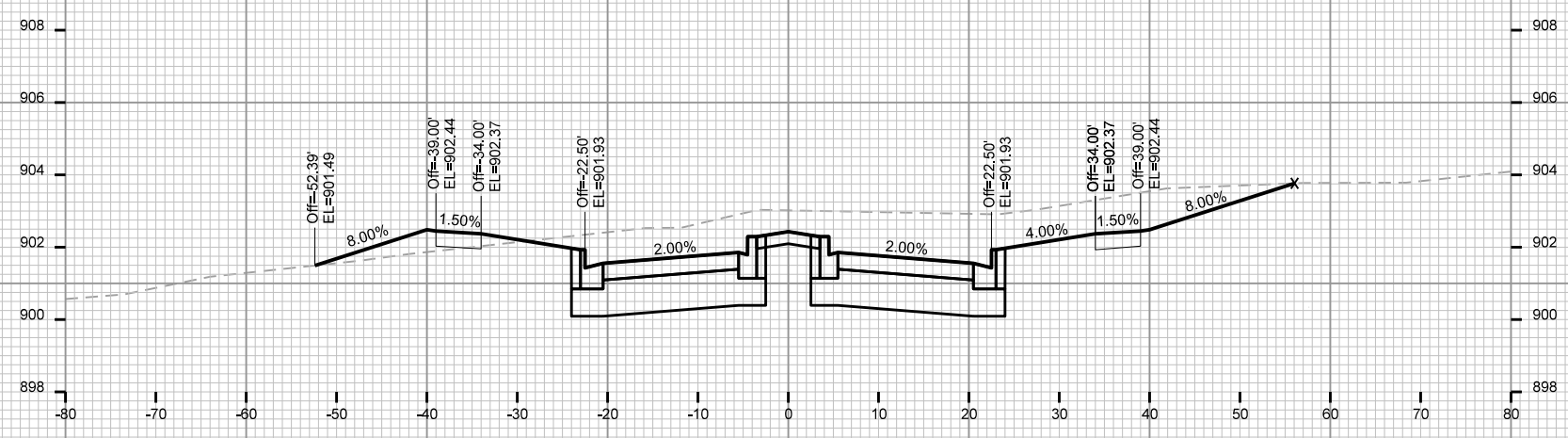
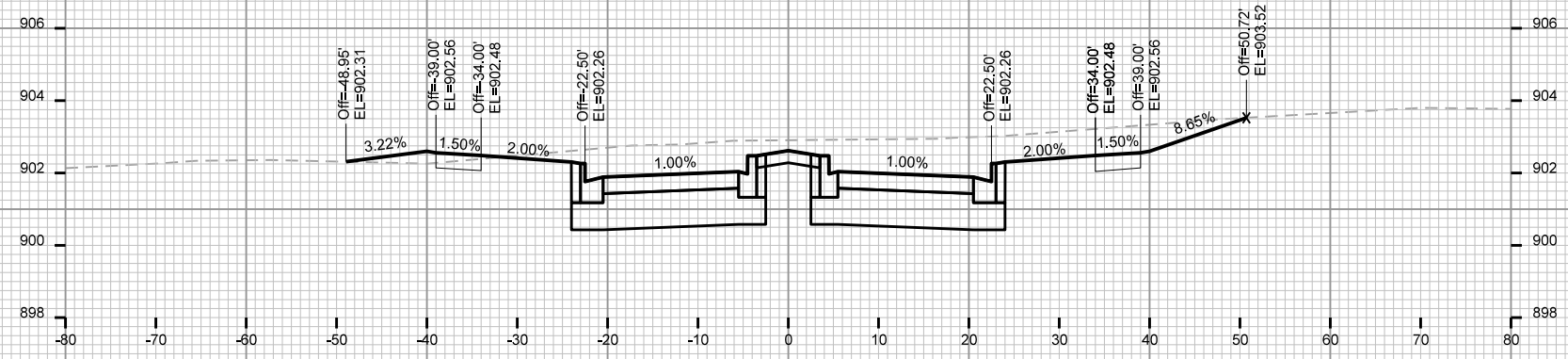

PLOT SCALE: _____

PLOT NAME: _____

REV. DATE: _____

ORIGINATOR: CITY OF MADISON, STREETS DIVISION

CROSS SECTIONS

CITY VIEW DRIVE

CITY OF MADISON

PLOT SCALE: _____

PLOT NAME: _____

REV. DATE: _____

ORIGINATOR: CITY OF MADISON, STREETS DIVISION

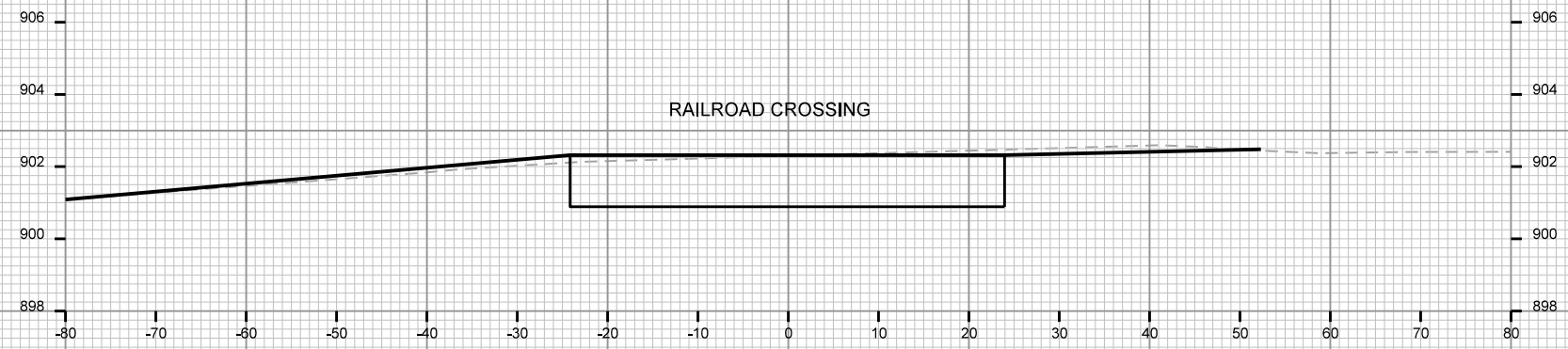

STA. 34+50



REVISION 8/21/20 AJZ
- Revised City View cross sections

CROSS SECTIONS

CITY VIEW DRIVE

CITY OF MADISON

PLOT SCALE: _____

PLOT NAME: _____

REV. DATE: _____

ORIGINATOR: CITY OF MADISON, STREETS DIVISION

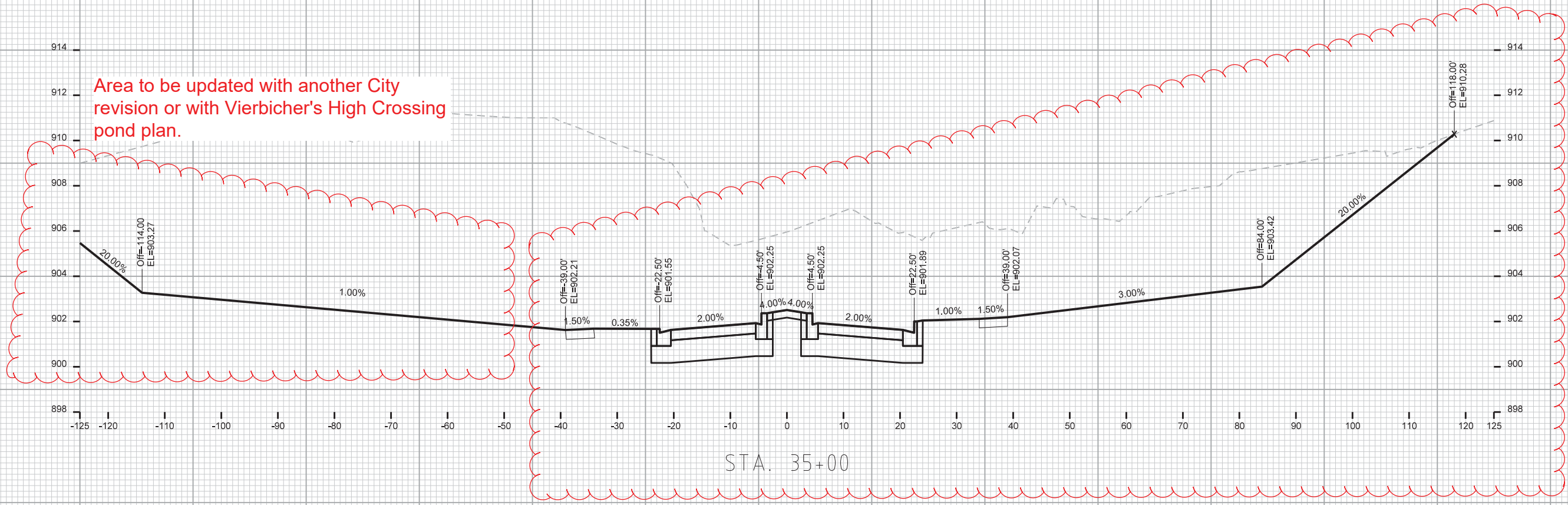

STA. 35+00

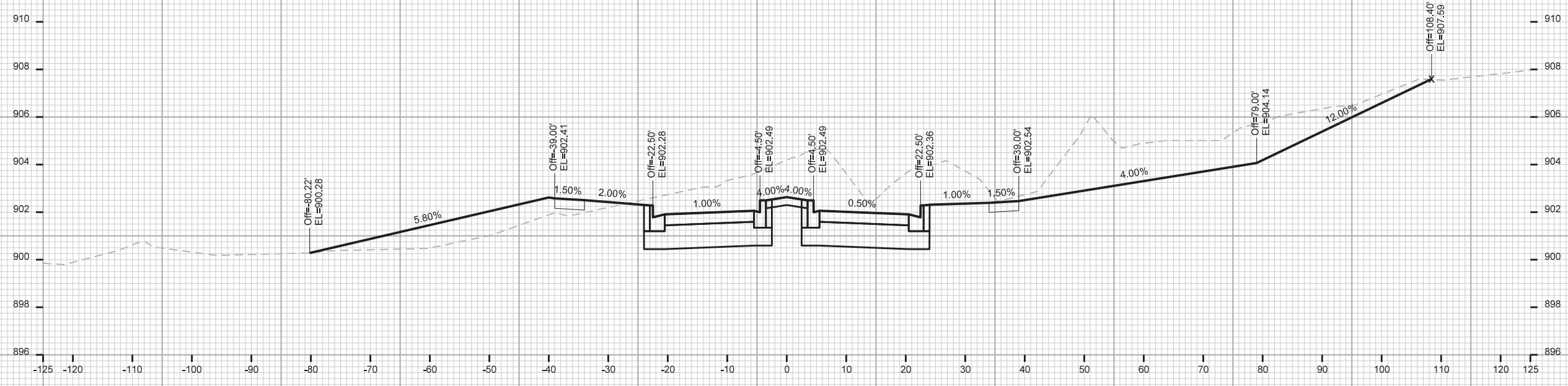

STA. 34+75

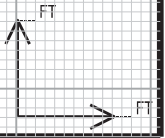

CROSS SECTIONS

CITY VIEW DRIVE CITY OF MADISON

REVISION 10/2/20 AJZ
- Revised City View Profile

PLOT SCALE: _____

PLOT NAME: _____

REV. DATE: _____

ORIGINATOR: CITY OF MADISON, STREETS DIVISION

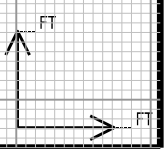
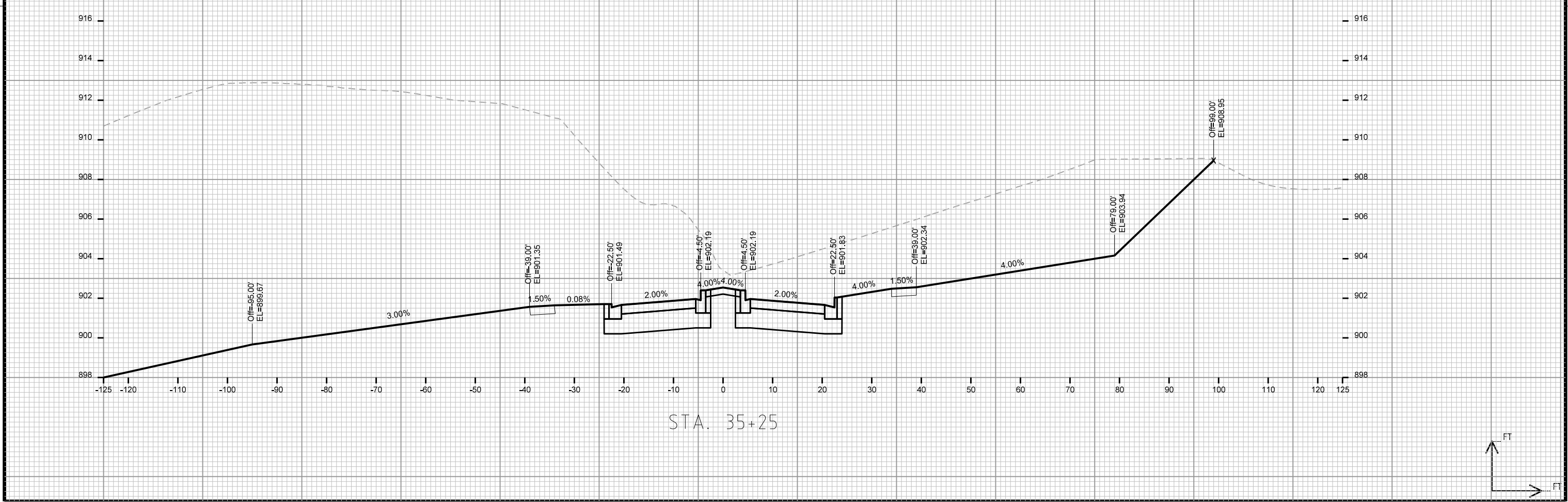
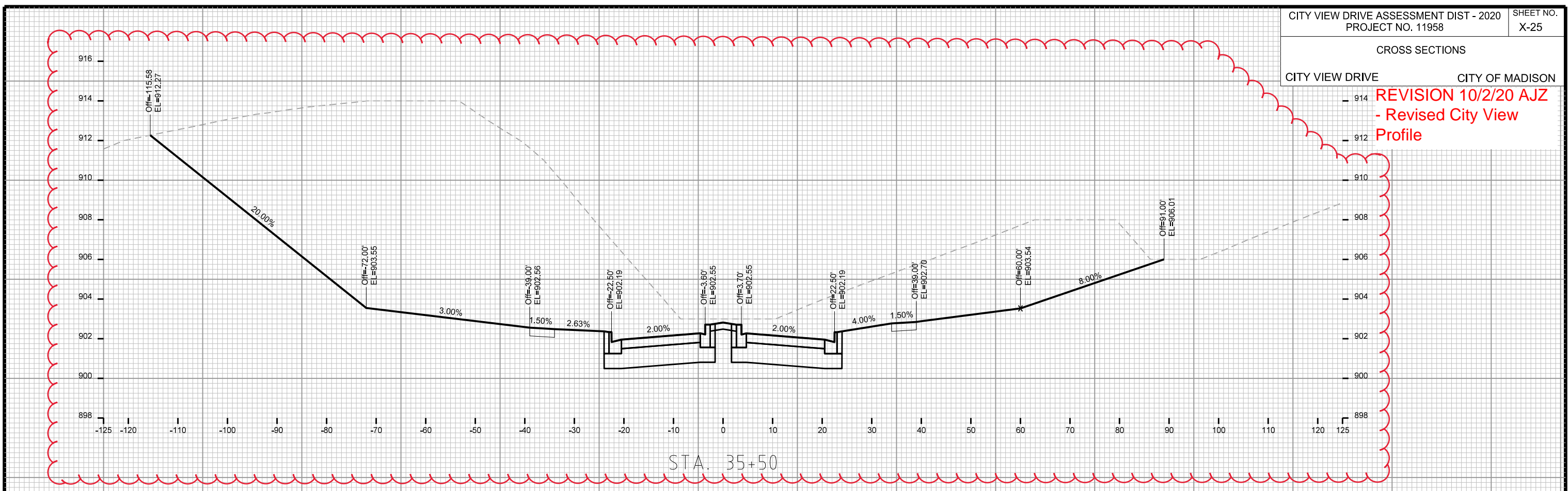

CROSS SECTIONS

CITY VIEW DRIVE CITY OF MADISON

REVISION 10/2/20 AJZ
- Revised City View Profile

PLOT SCALE: _____

PLOT NAME: _____

REV. DATE: _____

ORIGINATOR: CITY OF MADISON, STREETS DIVISION

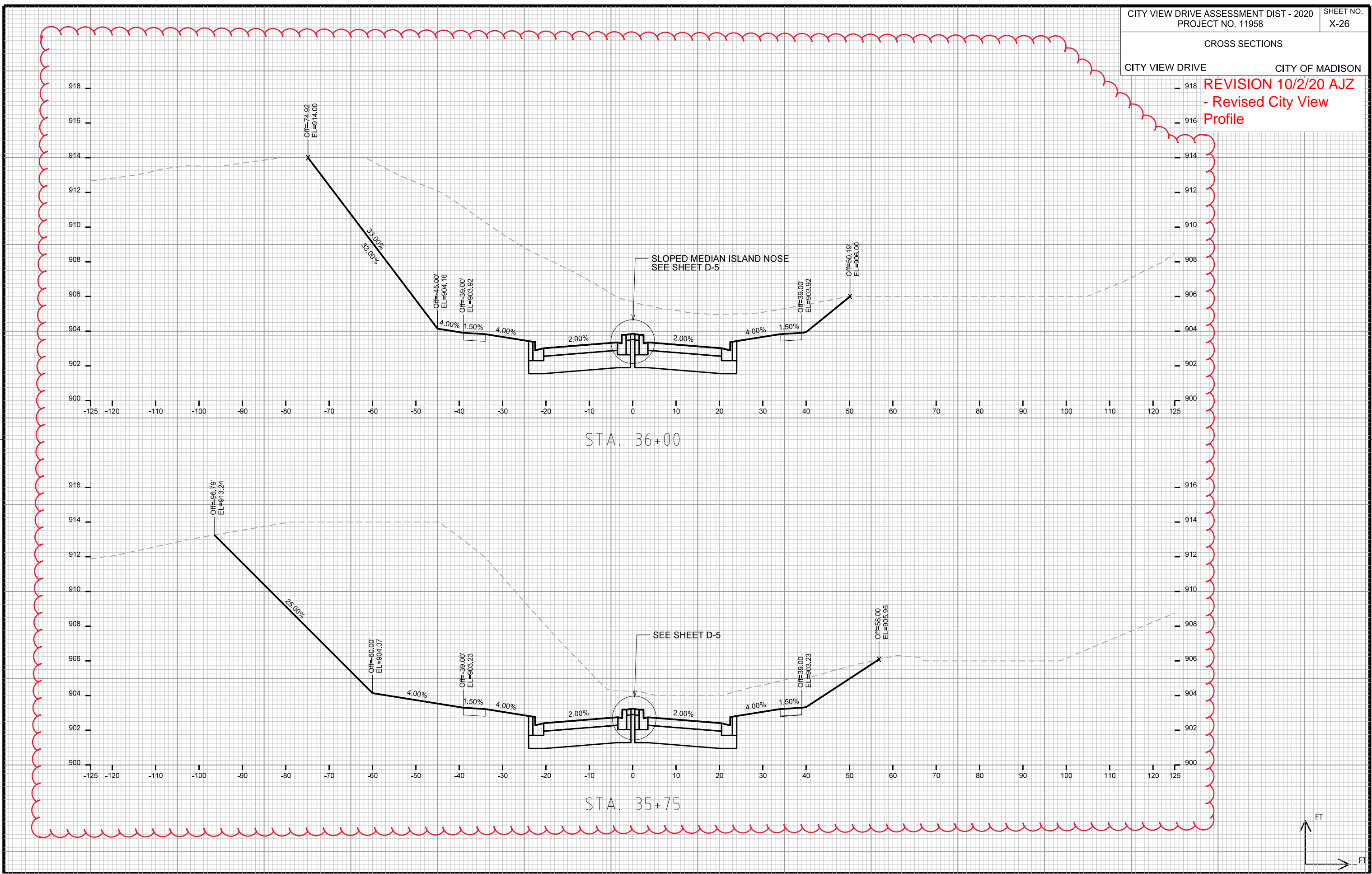

CROSS SECTIONS
CITY VIEW DRIVE CITY OF MADISON

REVISION 10/2/20 AJZ
- Revised City View Profile

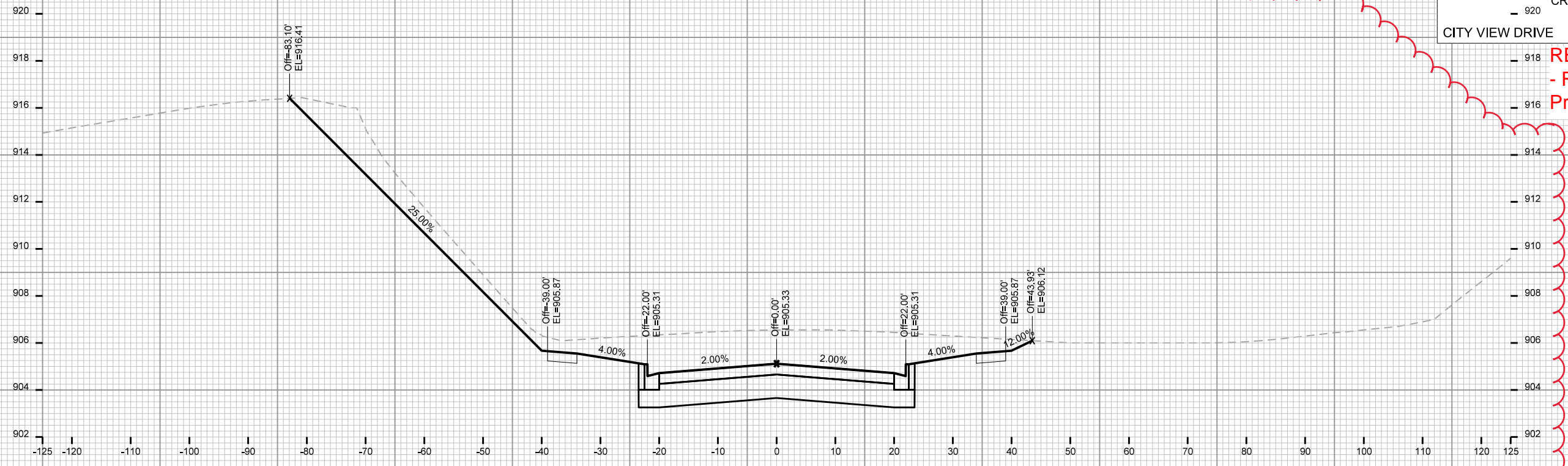

STA. 36+50



STA. 36+25

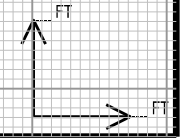

PLOT SCALE: _____

PLOT NAME: _____

REV. DATE: _____

ORIGINATOR: CITY OF MADISON, STREETS DIVISION

CROSS SECTIONS

CITY VIEW DRIVE CITY OF MADISON

REVISION 10/2/20 AJZ
- Revised City View Profile

PLOT SCALE: _____

PLOT NAME: _____

REV. DATE: _____

ORIGINATOR: CITY OF MADISON, STREETS DIVISION

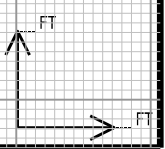
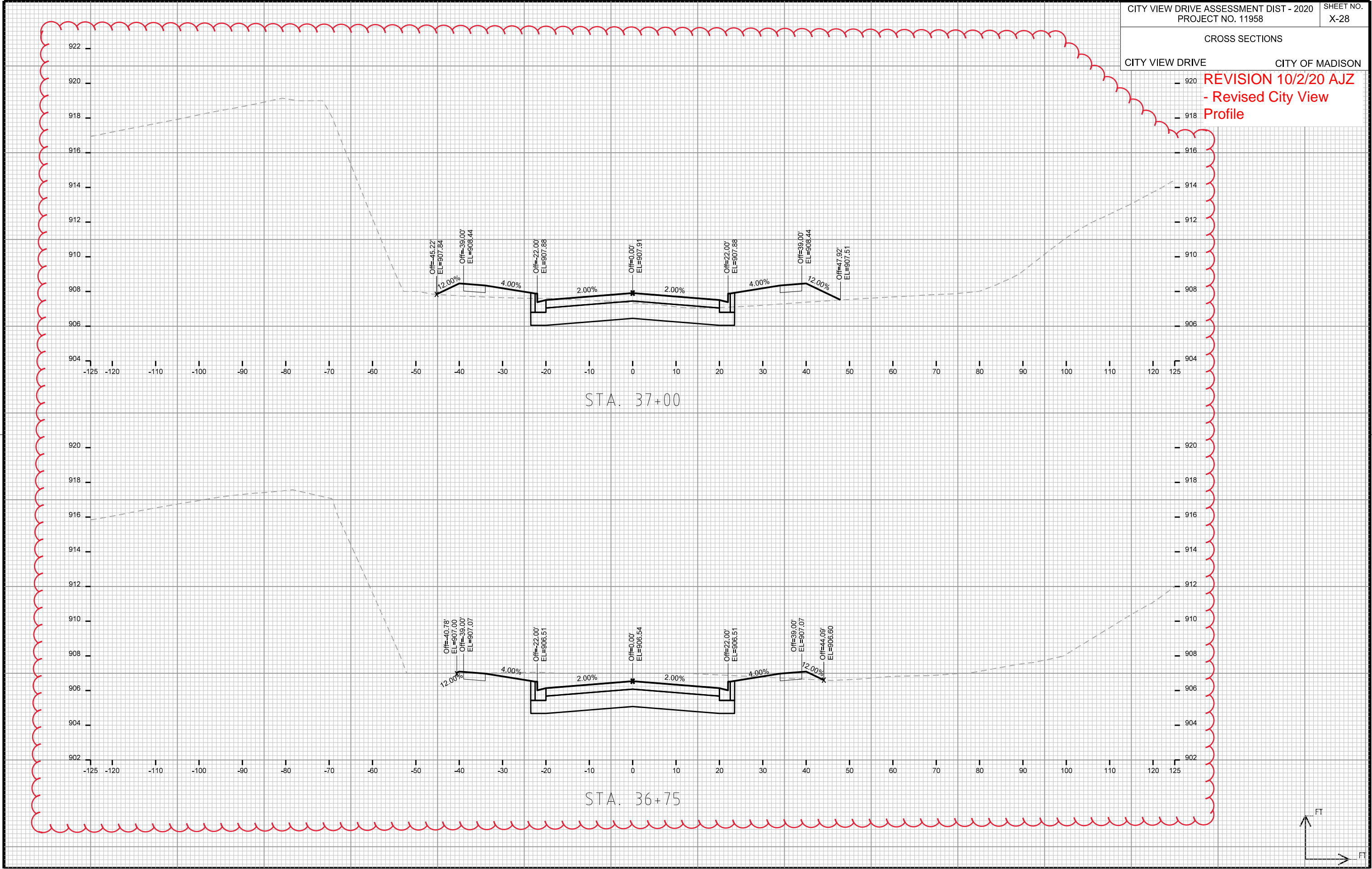

CROSS SECTIONS

CITY VIEW DRIVE CITY OF MADISON

REVISION 10/2/20 AJZ
- Revised City View Profile

PLOT SCALE: _____

PLOT NAME: _____

REV. DATE: _____

ORIGINATOR: CITY OF MADISON, STREETS DIVISION

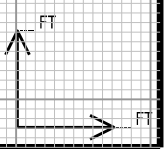
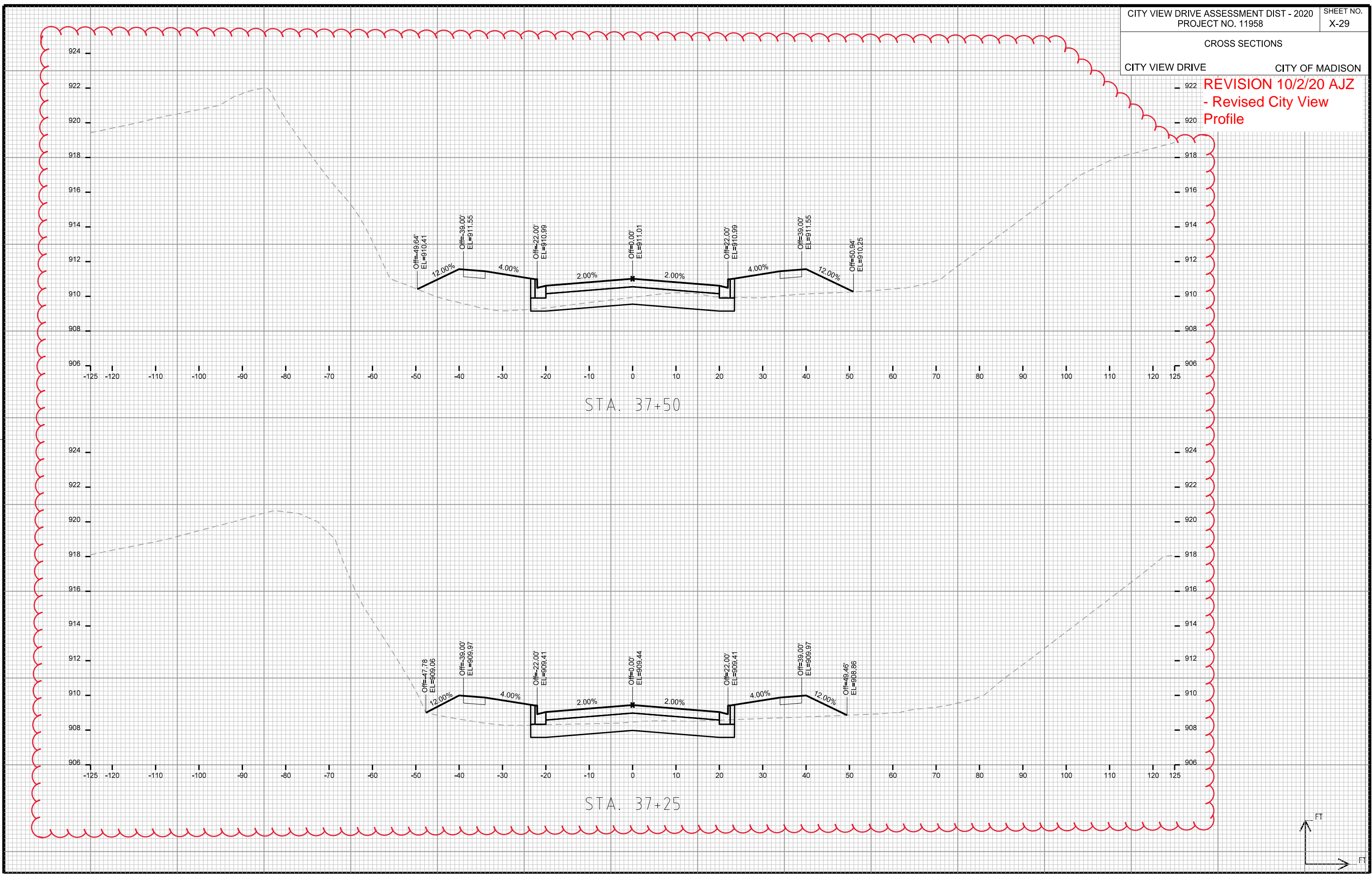

CROSS SECTIONS

CITY VIEW DRIVE CITY OF MADISON

REVISION 10/2/20 AJZ
- Revised City View
Profile

PLOT SCALE: _____

PLOT NAME: _____

REV. DATE: _____

ORIGINATOR: CITY OF MADISON, STREETS DIVISION

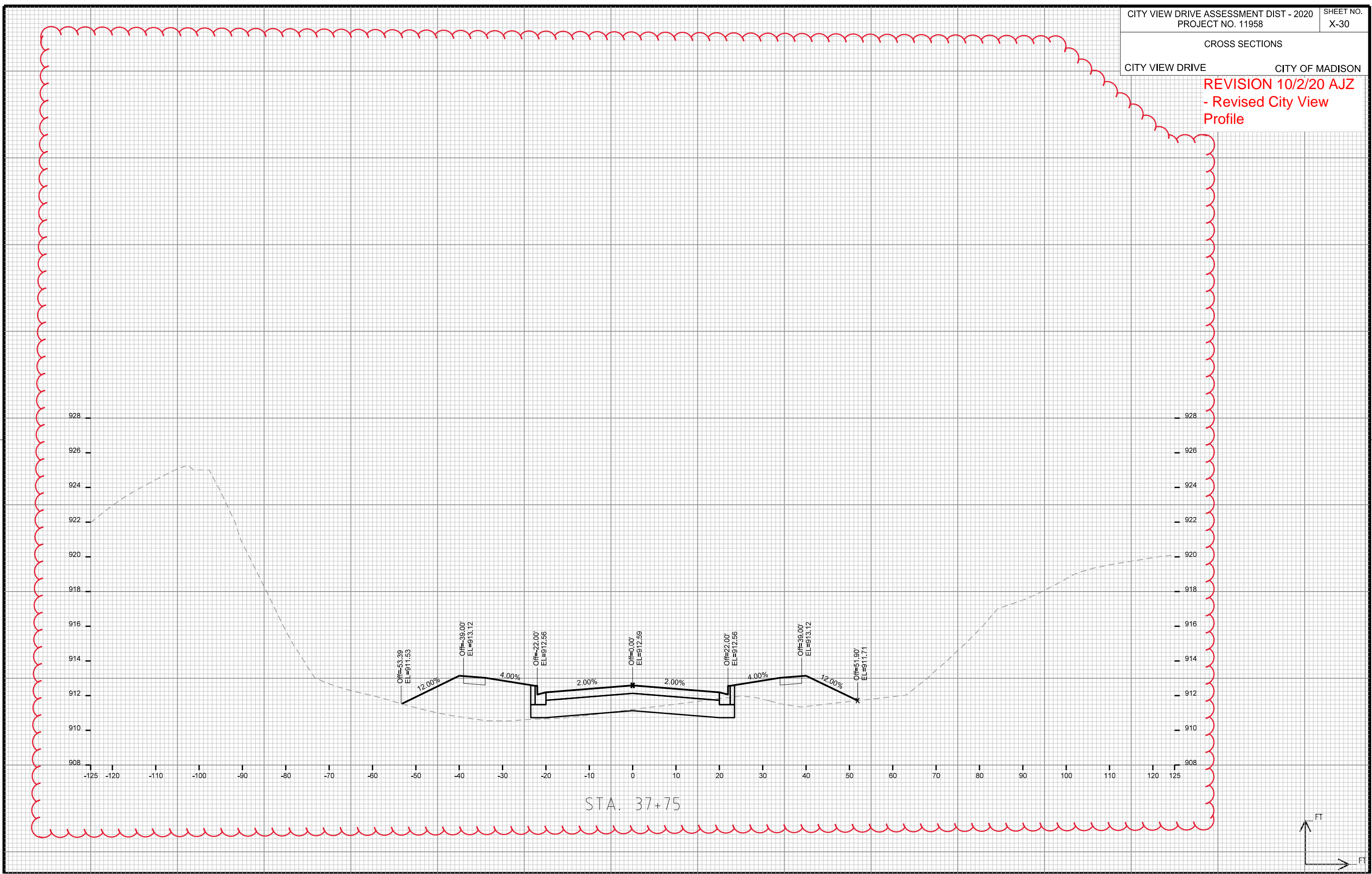

REVISION 10/2/20 AJZ
- Revised City View Profile

PLOT SCALE: _____

PLOT NAME: _____

REV. DATE: _____

ORIGINATOR: CITY OF MADISON, STREETS DIVISION

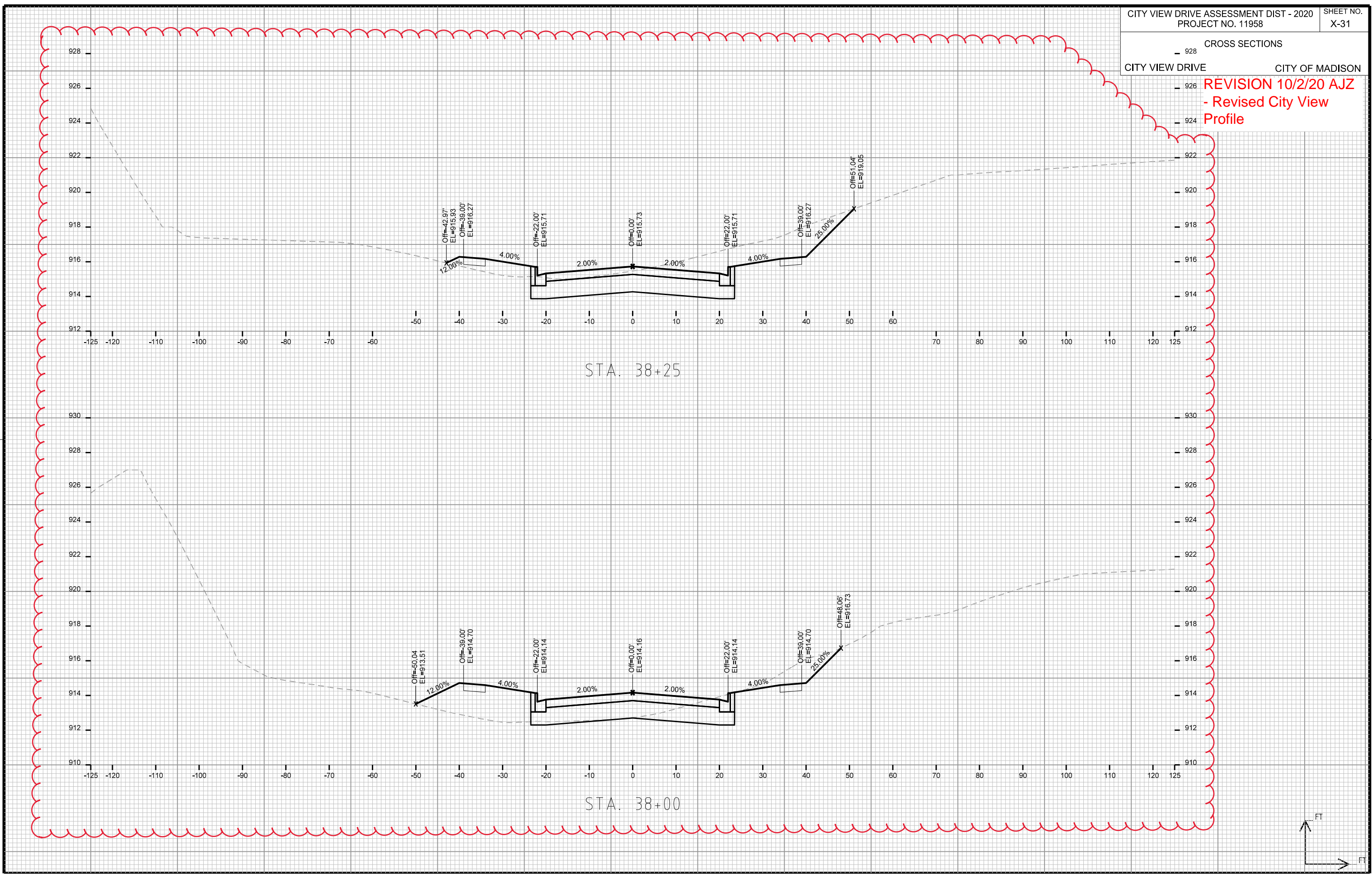

CROSS SECTIONS

CITY VIEW DRIVE CITY OF MADISON

REVISION 10/2/20 AJZ
- Revised City View Profile

PLOT SCALE: _____

PLOT NAME: _____

REV. DATE: _____

ORIGINATOR: CITY OF MADISON, STREETS DIVISION

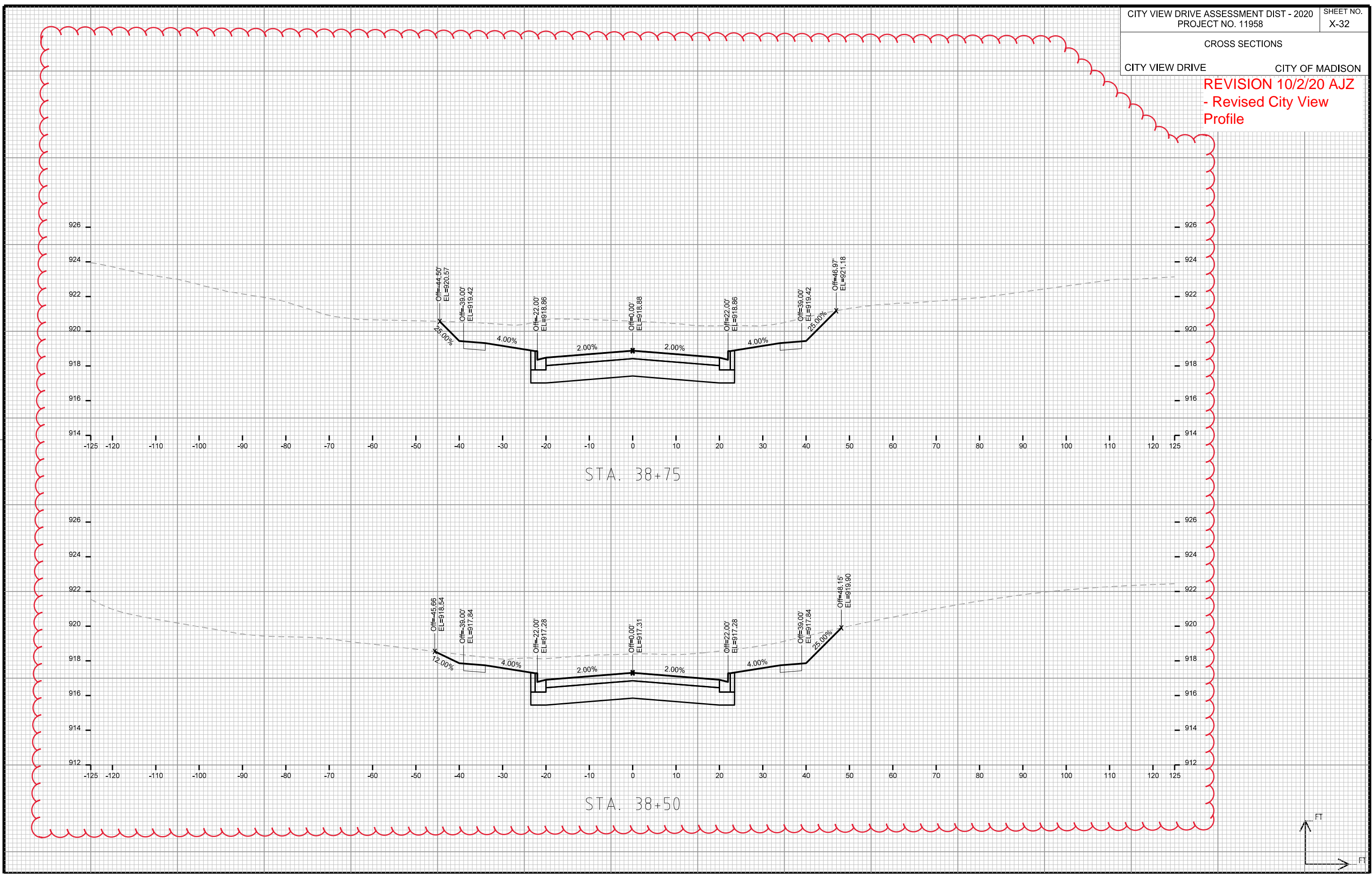

CROSS SECTIONS

CITY VIEW DRIVE CITY OF MADISON

REVISION 10/2/20 AJZ
- Revised City View Profile

PLOT SCALE: _____

PLOT NAME: _____

REV. DATE: _____

ORIGINATOR: CITY OF MADISON, STREETS DIVISION

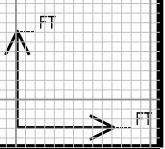
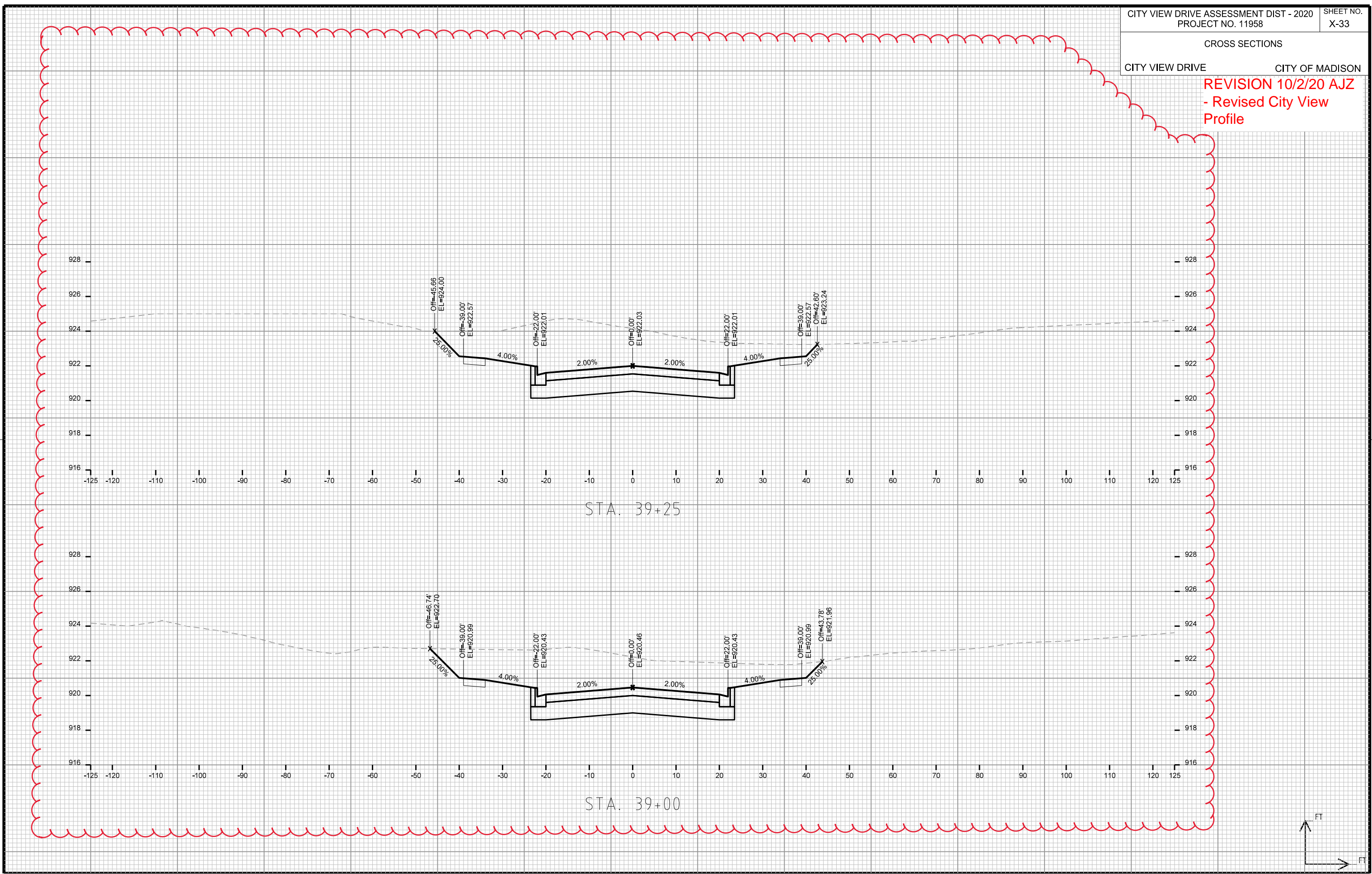

CROSS SECTIONS

CITY VIEW DRIVE CITY OF MADISON

REVISION 10/2/20 AJZ
- Revised City View Profile

PLOT SCALE: _____

PLOT NAME: _____

REV. DATE: _____

ORIGINATOR: CITY OF MADISON, STREETS DIVISION

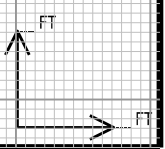
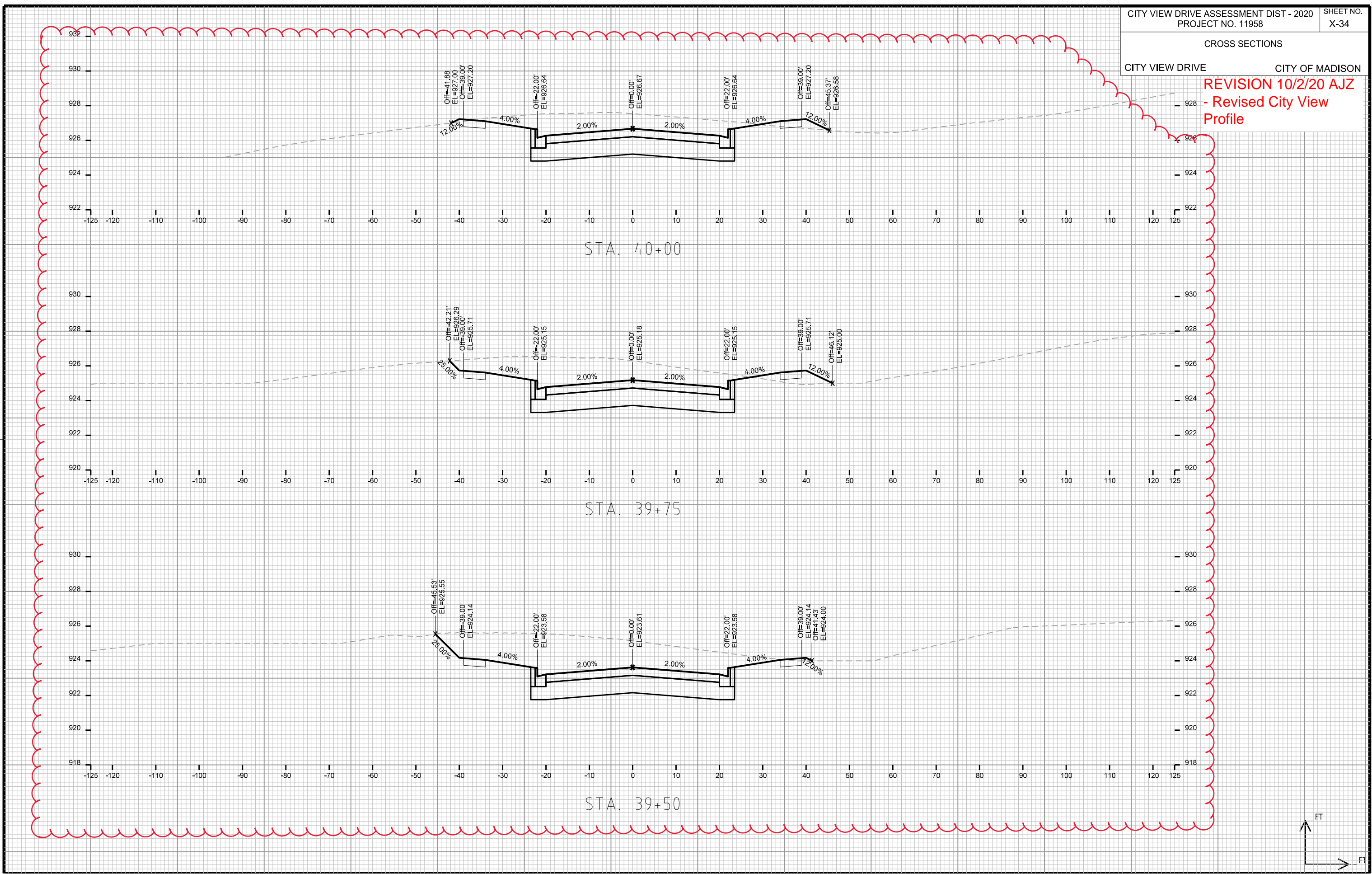

CROSS SECTIONS

CITY VIEW DRIVE CITY OF MADISON

REVISION 10/2/20 AJZ
- Revised City View Profile

PLOT SCALE: _____

PLOT NAME: _____

REV. DATE: _____

ORIGINATOR: CITY OF MADISON, STREETS DIVISION

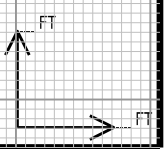
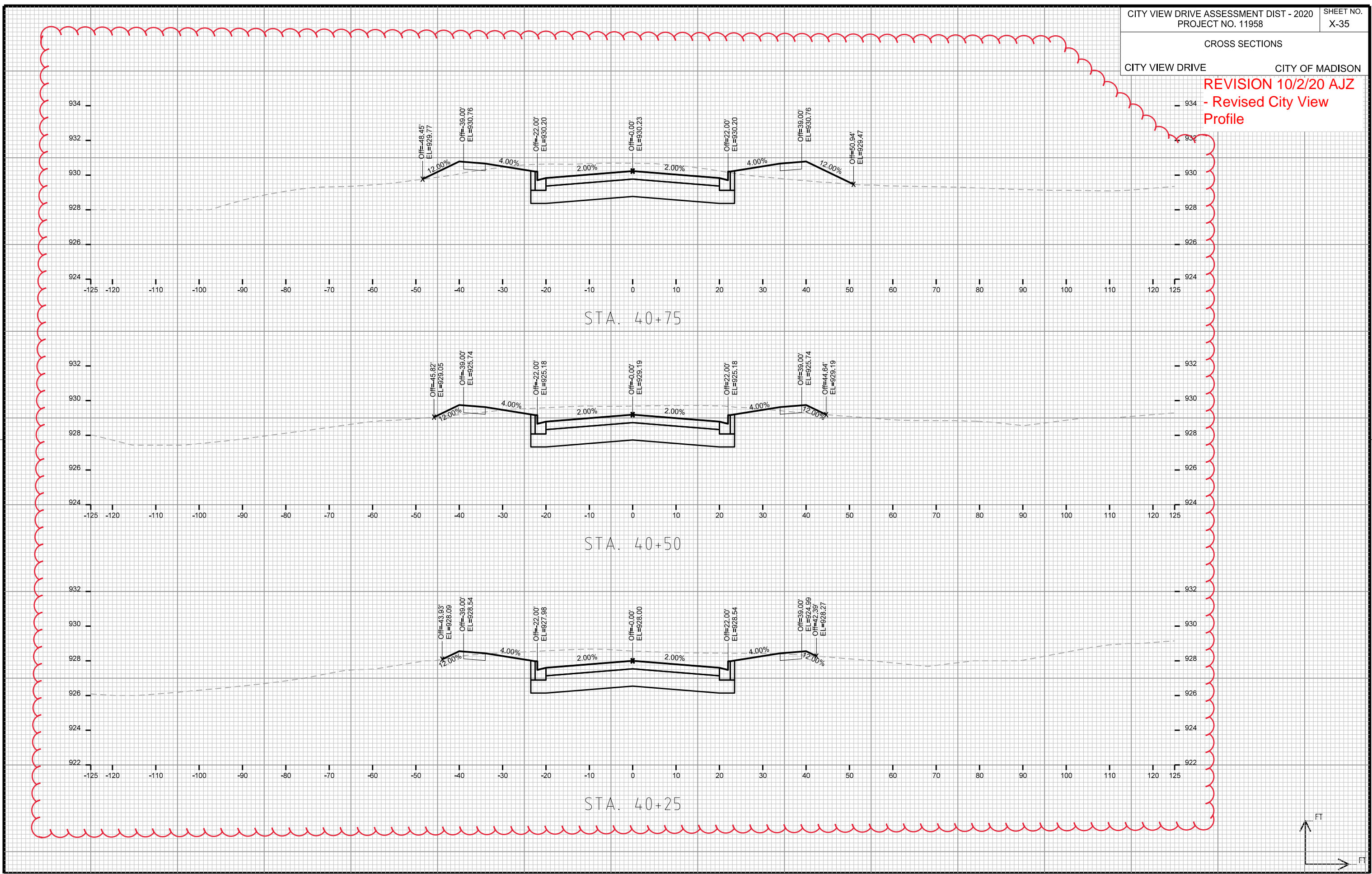

CROSS SECTIONS

CITY VIEW DRIVE CITY OF MADISON

REVISION 10/2/20 AJZ
- Revised City View Profile

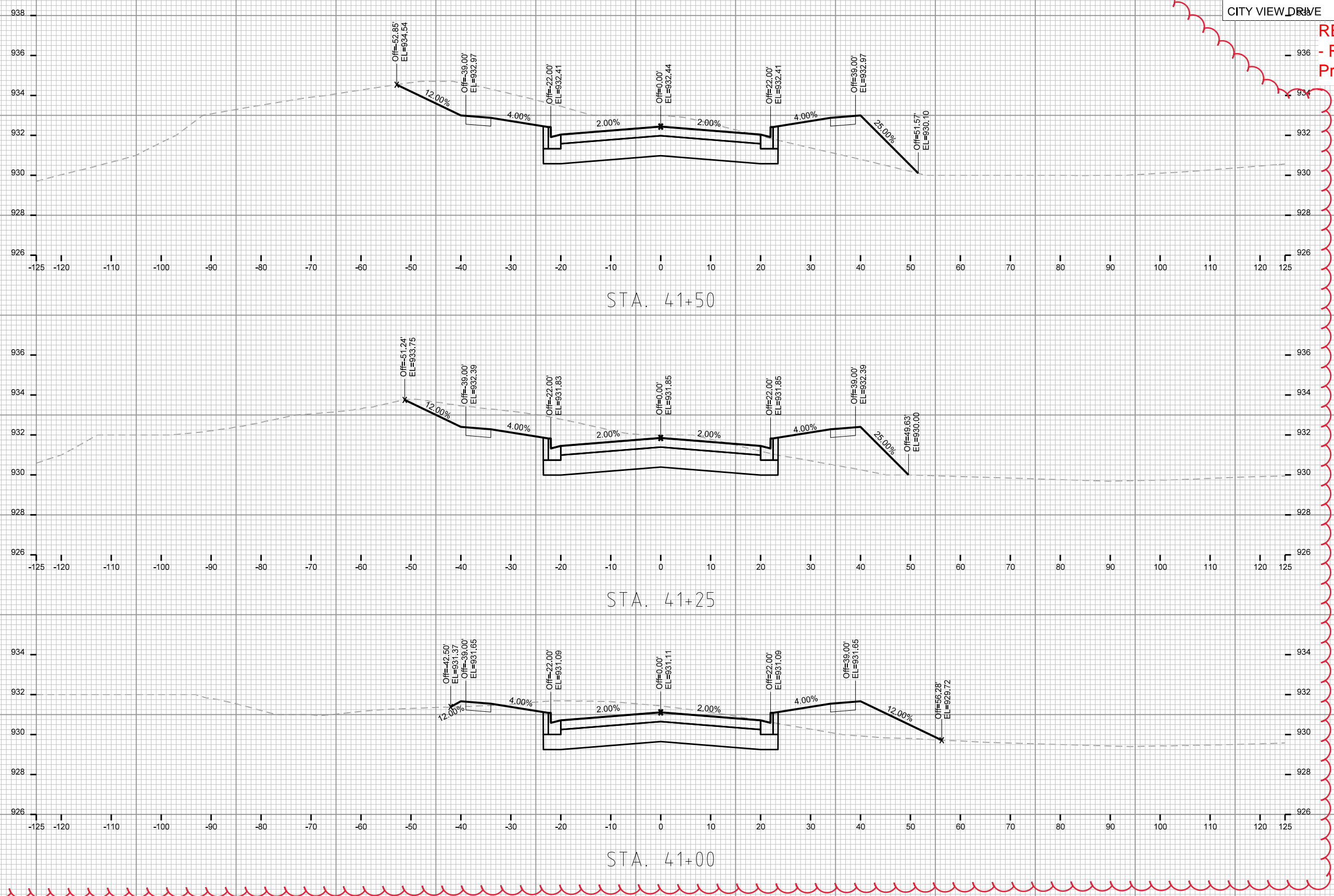

PLOT SCALE: _____

PLOT NAME: _____

REV. DATE: _____

ORIGINATOR: CITY OF MADISON, STREETS DIVISION

CROSS SECTIONS

CITY VIEW DRIVE CITY OF MADISON

REVISION 10/2/20 AJZ
- Revised City View Profile

PLOT SCALE: _____

PLOT NAME: _____

REV. DATE: _____

ORIGINATOR: CITY OF MADISON, STREETS DIVISION

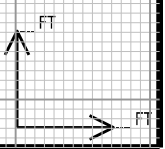
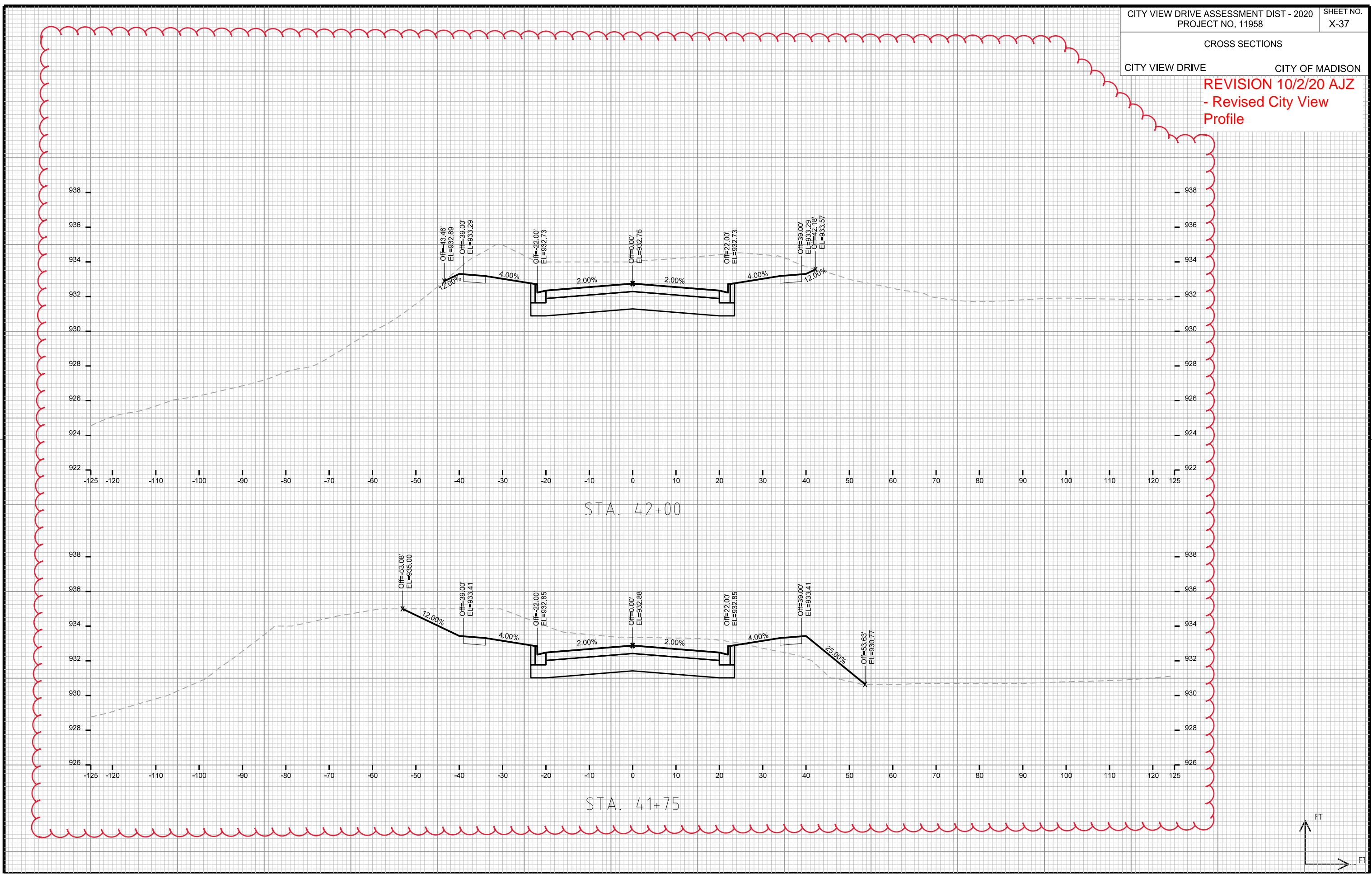

CROSS SECTIONS

CITY VIEW DRIVE CITY OF MADISON

REVISION 10/2/20 AJZ
- Revised City View
Profile

PLOT SCALE: _____

PLOT NAME: _____

REV. DATE: _____

ORIGINATOR: CITY OF MADISON, STREETS DIVISION

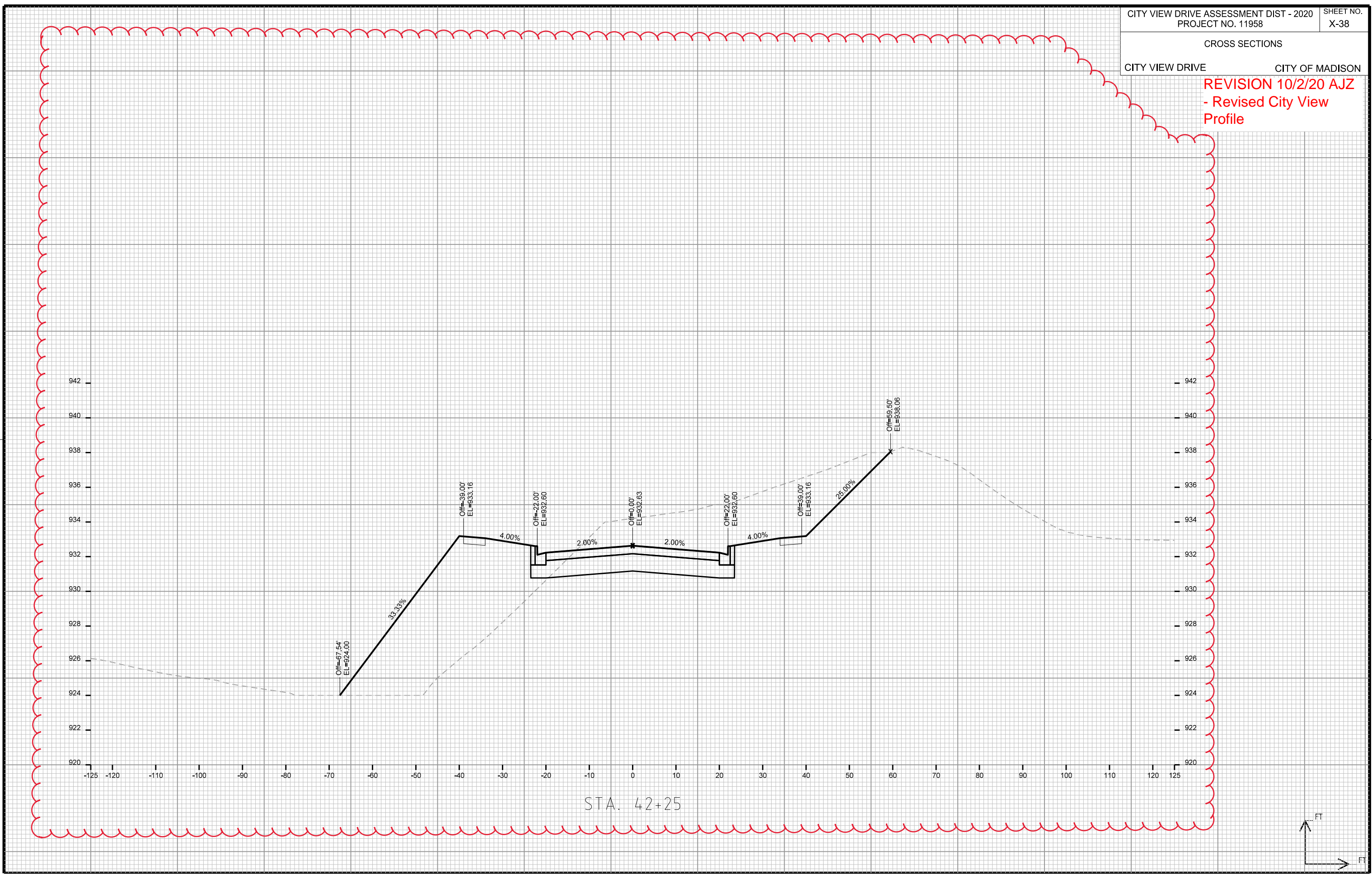

STA. 42+25

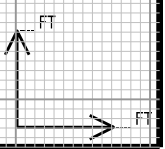

CROSS SECTIONS

CITY VIEW DRIVE CITY OF MADISON

REVISION 10/2/20 AJZ
- Revised City View
Profile

PLOT SCALE: _____

PLOT NAME: _____

REV. DATE: _____

ORIGINATOR: CITY OF MADISON, STREETS DIVISION

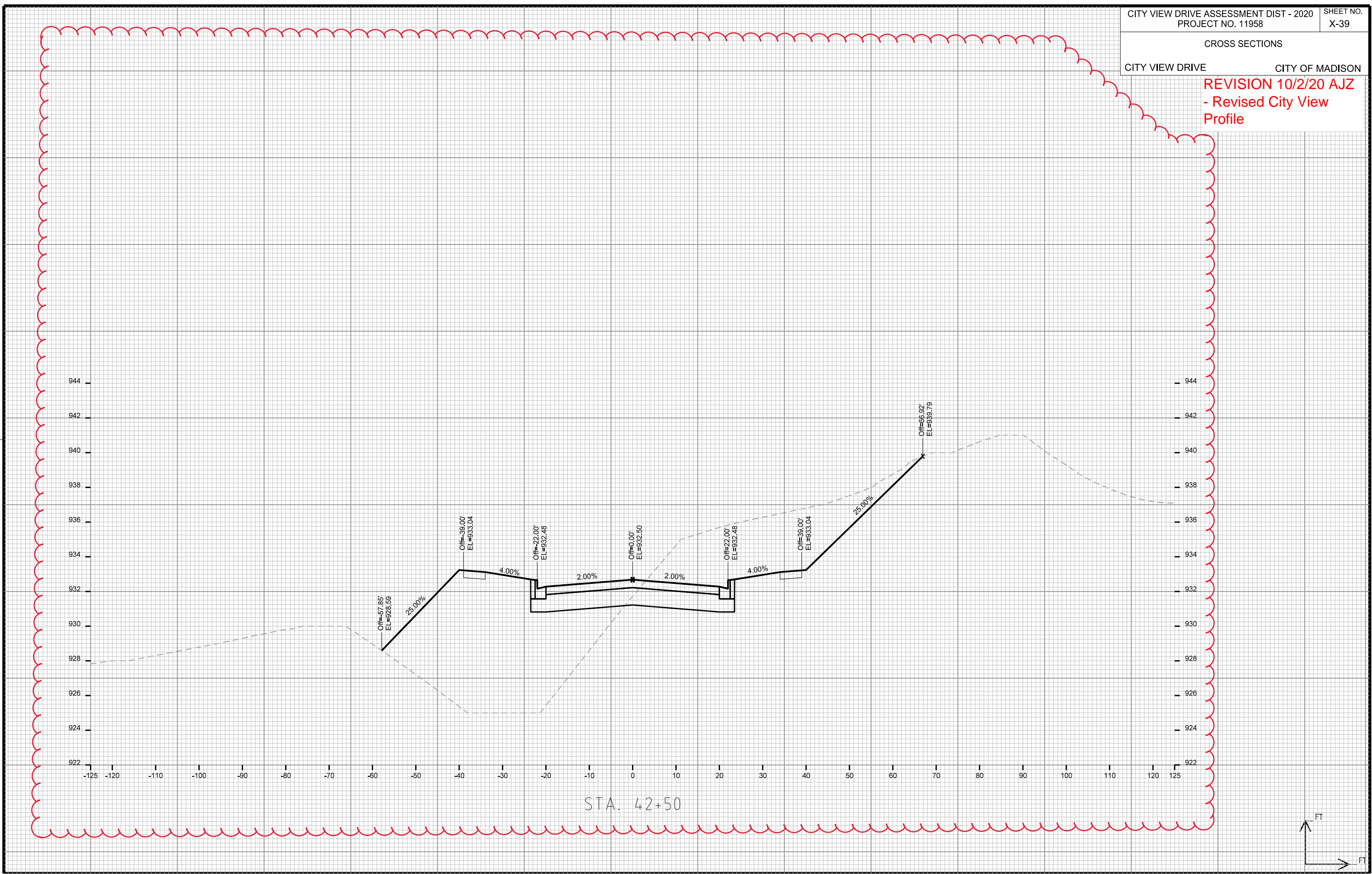

CROSS SECTIONS

CITY VIEW DRIVE CITY OF MADISON

REVISION 10/2/20 AJZ
- Revised City View Profile

PLOT SCALE: _____

PLOT NAME: _____

REV. DATE: _____

ORIGINATOR: CITY OF MADISON, STREETS DIVISION

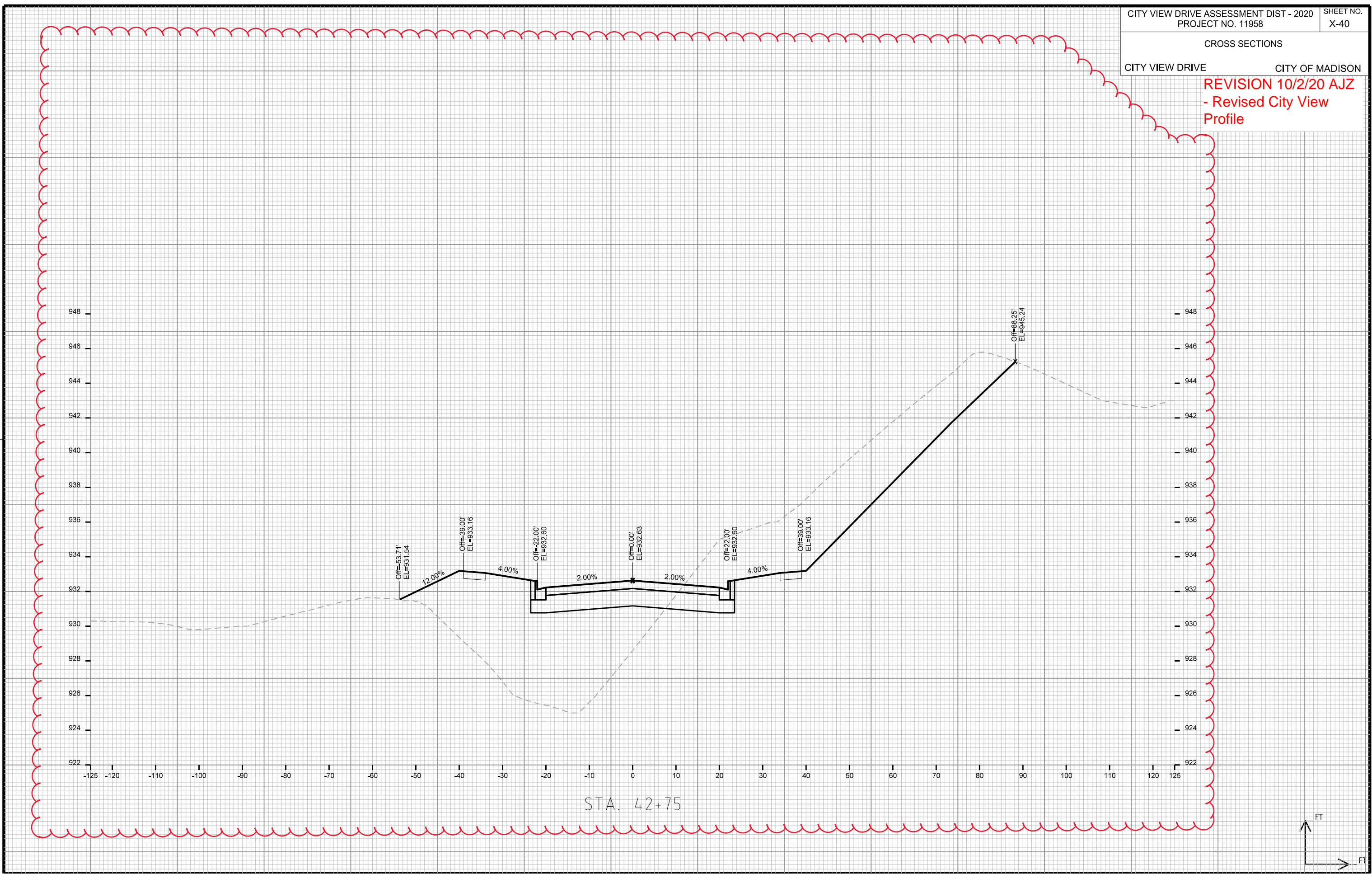

STA. 42+75



CROSS SECTIONS

CITY VIEW DRIVE CITY OF MADISON

REVISION 10/2/20 AJZ
- Revised City View Profile

PLOT SCALE: _____

PLOT NAME: _____

REV. DATE: _____

ORIGINATOR: CITY OF MADISON, STREETS DIVISION

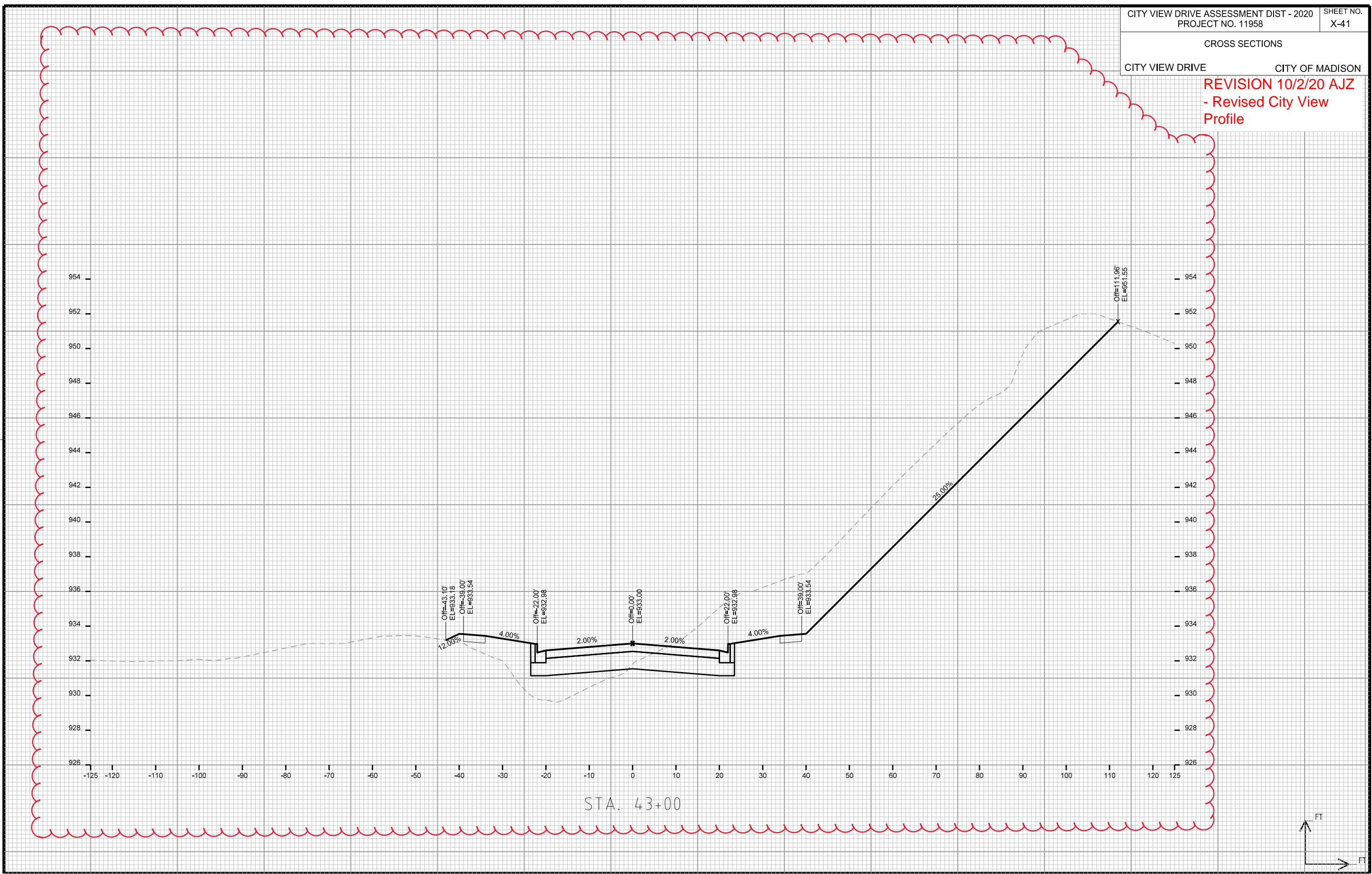

CROSS SECTIONS

CITY VIEW DRIVE CITY OF MADISON

REVISION 10/2/20 AJZ
- Revised City View Profile

PLOT SCALE: _____
PLOT NAME: _____
REV. DATE: _____
ORIGINATOR: CITY OF MADISON, STREETS DIVISION

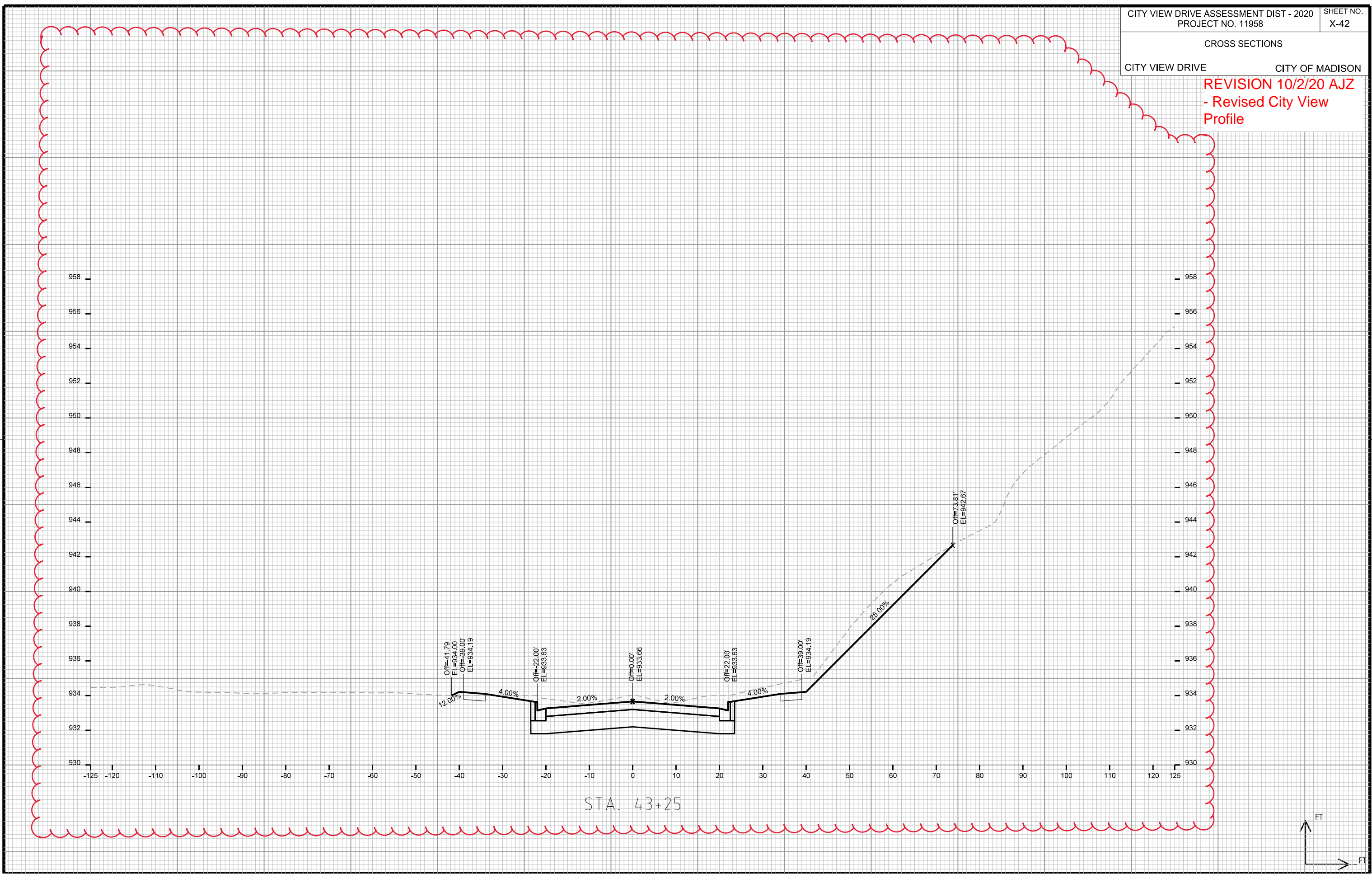

REVISION 10/2/20 AJZ
- Revised City View Profile

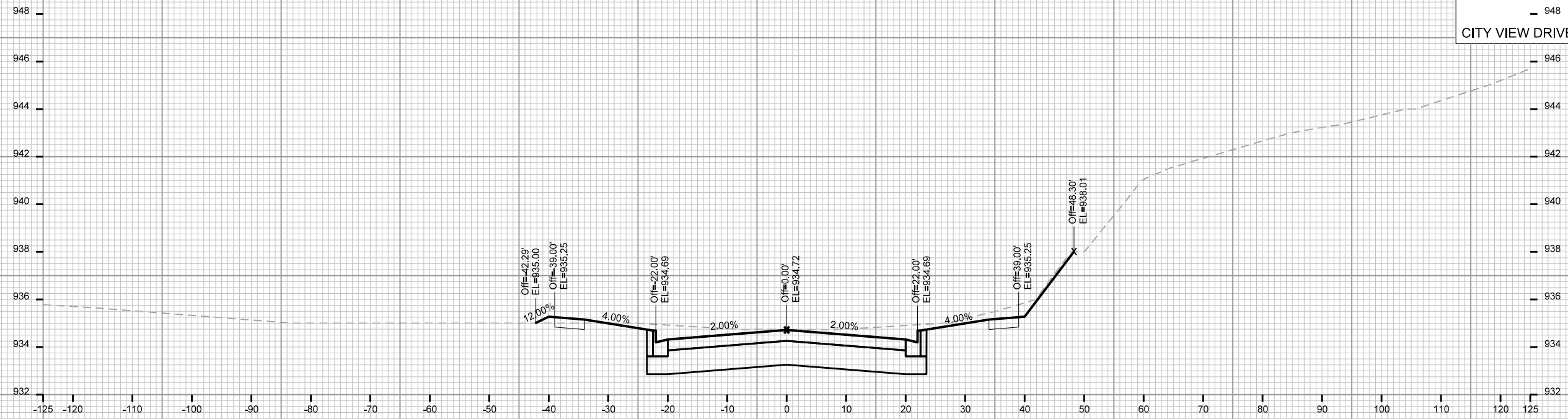

STA. 43+75

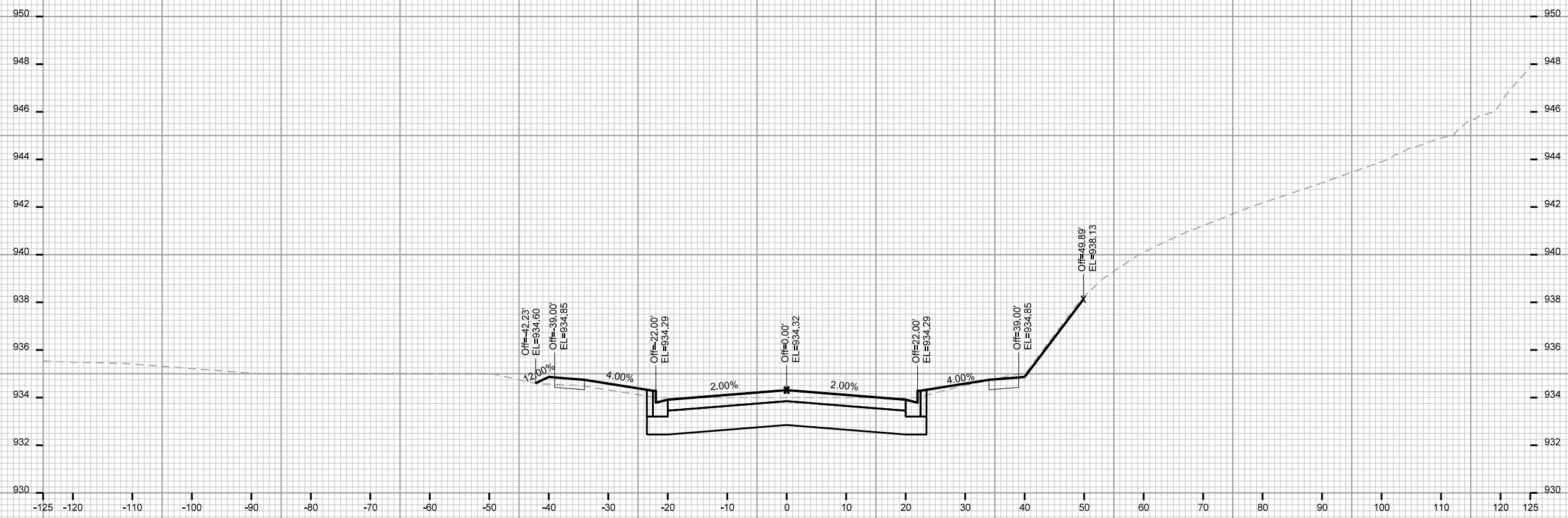

STA. 43+50

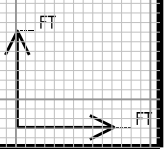

PLOT SCALE: _____

PLOT NAME: _____

REV. DATE: _____

ORIGINATOR: CITY OF MADISON, STREETS DIVISION